

# CHM<sup>®</sup>

















**CHARFIX** *system 2*







## INTRAMEDULLARY OSTEOSYNTHESIS OF FEMUR WITH ANATOMICAL FEMORAL NAILS

- *IMPLANTS*
- *INSTRUMENT SET 40.5500.500*
- *SURGICAL TECHNIQUE*



## SYMBOLS DESCRIPTION

	Pure titanium		Cannulated
	Titanium alloy		Locking
	Steel		Diameter
	Left		Inner diameter
	Right		Recommended length range for a particular nail
	Available versions: left/right		Angle
	Length		Available lengths
	Torx drive		Available in sterile/ non- sterile condition
	Torx drive cannulated		
	Hexagonal drive		
	Hexagonal drive cannulated		

	Caution - pay attention to a special procedure.
	Perform the activity under X-Ray control.
	Information about the next stages of a procedure.
	Proceed to the next stage.
	Return to the specified stage and repeat the activity.
	Before using the product, carefully read the Instructions for Use. It contains, among others, indications, contraindications, side effects, recommendations and warnings related to the use of the product.
	The above description is not a detailed instruction of conduct. The surgeon decides about choosing the operating procedure.

**www.chm.eu**

Document No ST/34C  
 Date of issue 27.07.2009  
 Review date P-012-07.01.2025

*The manufacturer reserves the right to introduce design changes.*

*Updated INSTRUCTIONS FOR USE are available at the following website: ifu.chm.eu*

---

I. INTRODUCTION	4
II. METHODS OF OSTEOSYNTHESIS USING ANATOMICAL FEMORAL NAILS	5
II.1. RECONSTRUCTION METHOD	5
II.2. STATIC METHOD USING RECONSTRUCTION SCREW	6
II.3. COMPRESSION METHOD	7
II.4. DYNAMIC METHOD	8
II.5. SECONDARY DYNAMIZATION METHOD	9
II.6. STATIC LOCKING	10
III. IMPLANTS	12
IV. INSTRUMENT SET	15
V. SURGICAL TECHNIQUE	17
V.1. PLANNING THE PROCEDURE	17
V.2. PATIENT POSITIONING	18
V.3. REDUCTION OF FRACTURE	18
V.4. SURGICAL APPROACH	18
V.5. ENTRY POINT	19
V.6. OPENING AND PREPARATION OF MEDULLARY CANAL AND NAIL INSERTION	20
V.7. LOCKING THE NAIL	26
V.8. NAIL REMOVAL	64

## I. INTRODUCTION

### CHARFIX *system 2*

- a new system of intramedullary locking nails designed on the basis of existing **CHARFIX** system of **ChM** sp. z o.o,
- combines experience of **ChM** sp. z o.o with up-to-date, innovative design solutions in intramedullary osteosynthesis,
- enables complex treatment of long bones fractures with intramedullary static, dynamic, compression and reconstruction osteosynthesis.

The presented range of implants is made of titanium and its alloys and implantable steel in accordance with ISO 5832 standard.

### CHARFIX *system 2*

- intramedullary osteosynthesis of femur with anatomical femoral nails, consists of:
- implants (*intramedullary nails, reconstruction screws, locking screws, compression screws and end caps*),
- instruments for implantation and implants removal after finished treatment,
- instructions for Use.

### CHARFIX *system 2*

– intramedullary osteosynthesis of femur with anatomical femoral nails enables, depending on femur fracture type, intramedullary fixation of its fragments with the following methods:

- reconstruction,
- compression,
- compression with intra-operative compression,
- dynamic,
- secondary dynamization (*dynamization of static fixation*),
- static, using reconstruction screw,
- static.

## II. METHODS OF OSTEOSYNTHESIS USING ANATOMICAL FEMORAL NAILS

### II.1. RECONSTRUCTION METHOD

Reconstruction method of locking the anatomical femoral nail is used in intramedullary osteosyntheses of proximal femur, in femoral neck and trochanteric fractures, also combined with femoral shaft fractures. As a result of angular positioning of reconstruction screws, anatomical positioning of femoral head and trochanteric region in relation to femoral shaft is obtained. Right and left version of the nail are used, accordingly for right and left extremity.



Reconstructive locking.

Examples of fractures treated with this method:



## II.2. STATIC METHOD USING RECONSTRUCTION SCREW

Construction of anatomical femoral nail includes additional angular reconstruction hole directed to distal part of femur (so-called "antegrade") used in subtrochanteric static fixations of femoral shaft. This solution allows locking with static method using one screw in proximal part and performing only one incision in proximal part.



„Antegrade“ locking.

Examples of fractures treated with this method:



### II.3. COMPRESSION METHOD

Compression of fragments can be performed with use of compression screw (*implant*), or intraoperatively using compression screw (*instrument*).

Anatomical femoral nail allows fragments compression through their movement along axis of the nail until their edges contact. The purpose of that procedure is to restore shape of the bone and stimulation of bone tissue growth in fracture site. It is necessary to use compression screw to obtain the compression.

Compression of fragments can be performed intraoperatively without disconnecting the targeter from the nail, which is necessary in classical compression method. This solution allows to obtain final static fixation through use of the intraoperative fragments compression, also reducing the operative time.



Compressive locking.

Examples of fractures treated with this method:



## II.4. DYNAMIC METHOD

Locking the nail in proximal part in compression hole without compression allows for dynamic fixation of bone fragments. This solution is used in case, when continuous mobility of fragments is required for stimulation of ossification process.



Examples of fractures treated with this method:

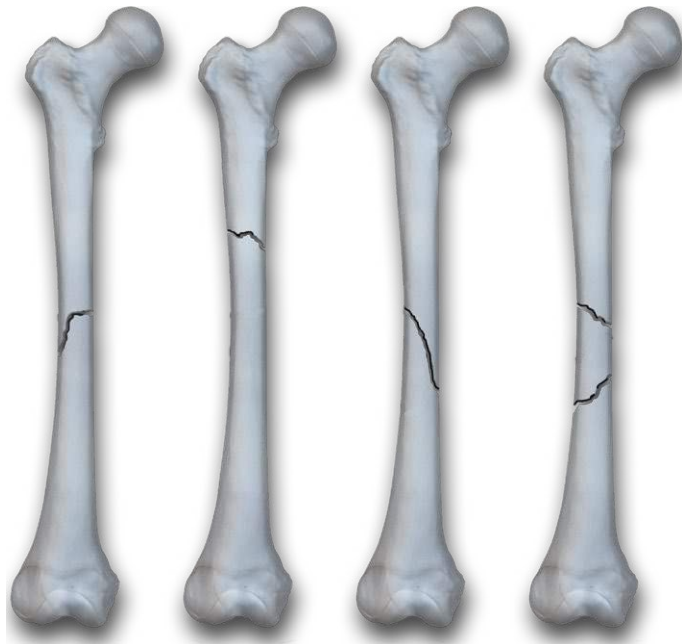

Dynamic locking



## II.5. SECONDARY DYNAMIZATION METHOD

Construction of anatomical femoral nail includes possibility of static fixation dynamization through screw removal from static hole in distal part of the nail, and leaving one screw in compression hole. Dynamization procedure is performed when necessity for bone tissue stimulation occurs (*for example, non-union in fracture site*).



Examples of fractures treated with this method:

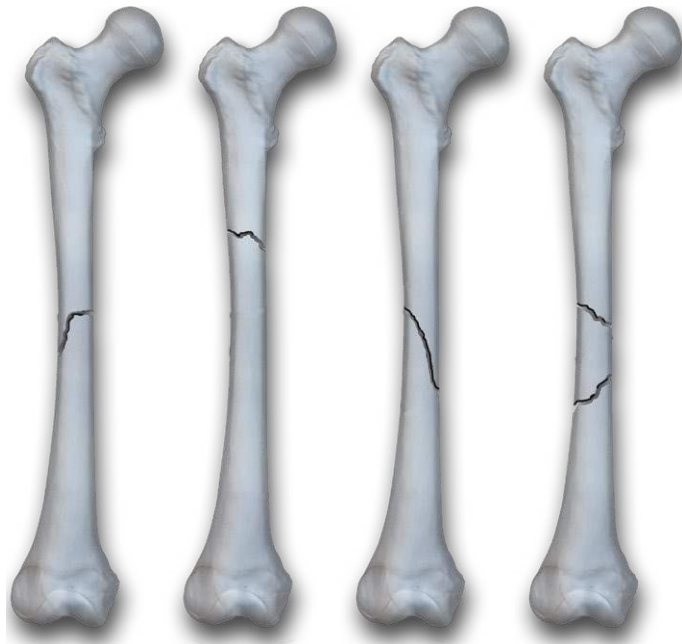

Dynamization of static fixation.

## II.6. STATIC LOCKING

Static locking of the nail is used to eliminate or reduce the movements in bone-nail-screws system. Construction of the implant allows for multiplane locking in 5 holes in distal part and for locking with 1, 2 or 3 screws in proximal part.



Static locking.

Examples of fractures treated with this method:

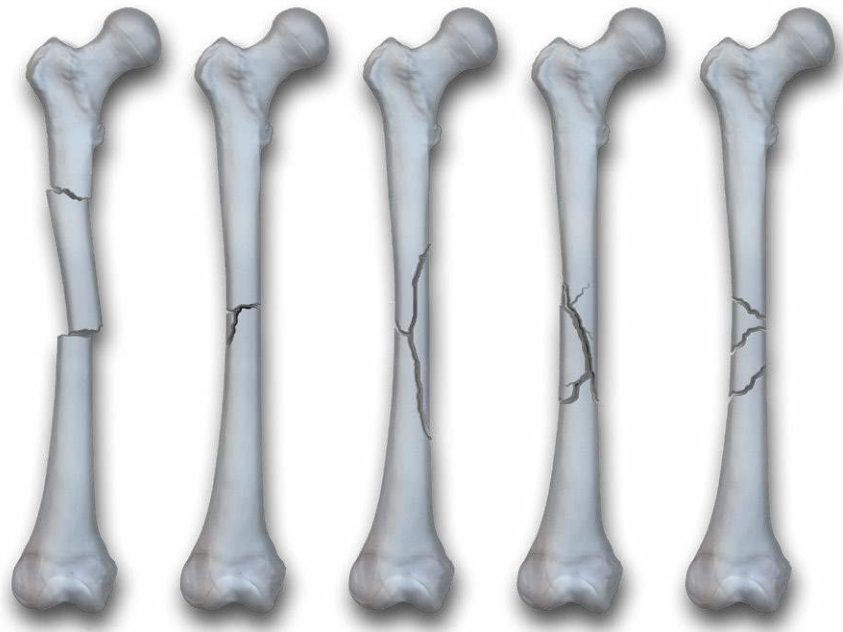

Threaded holes allow optional locking using:  
 - **CHARFIX2** Distal screw 5.0

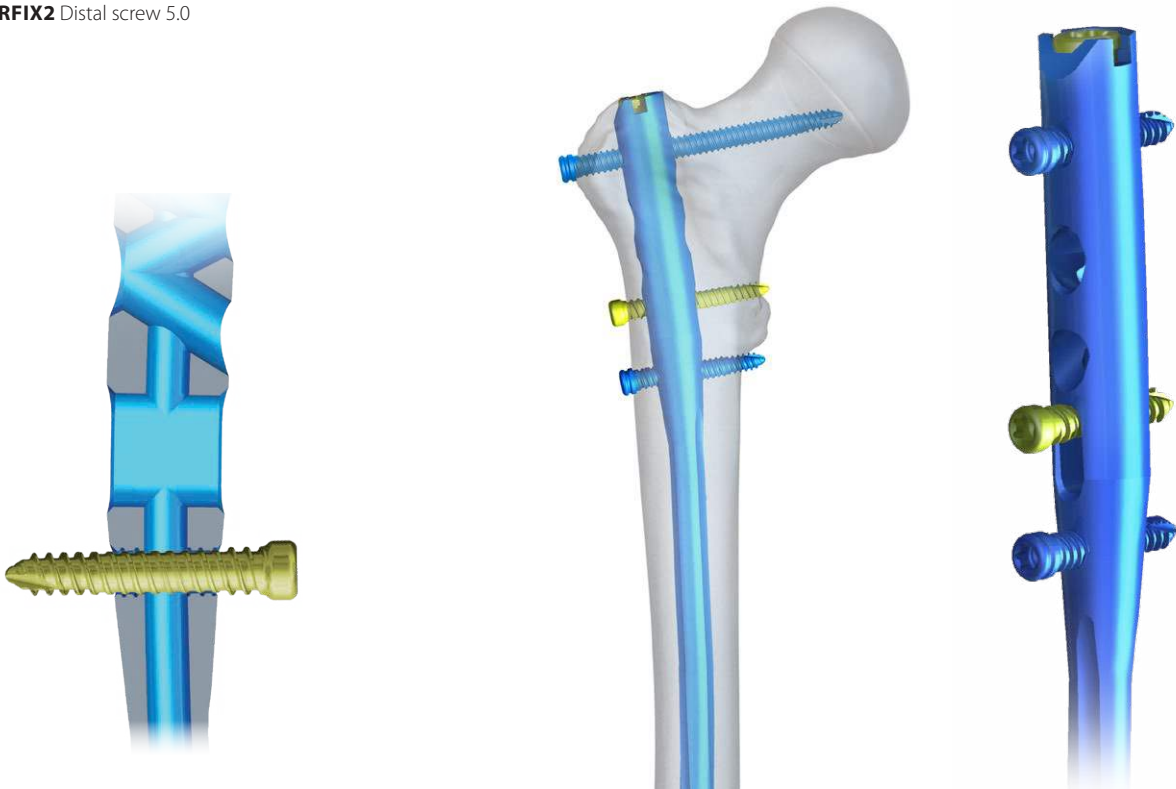

- **CHARFIX2** Distal screw 5.5 to prevent angular displacement of the bone fragments (*using threaded hole in the nail*).

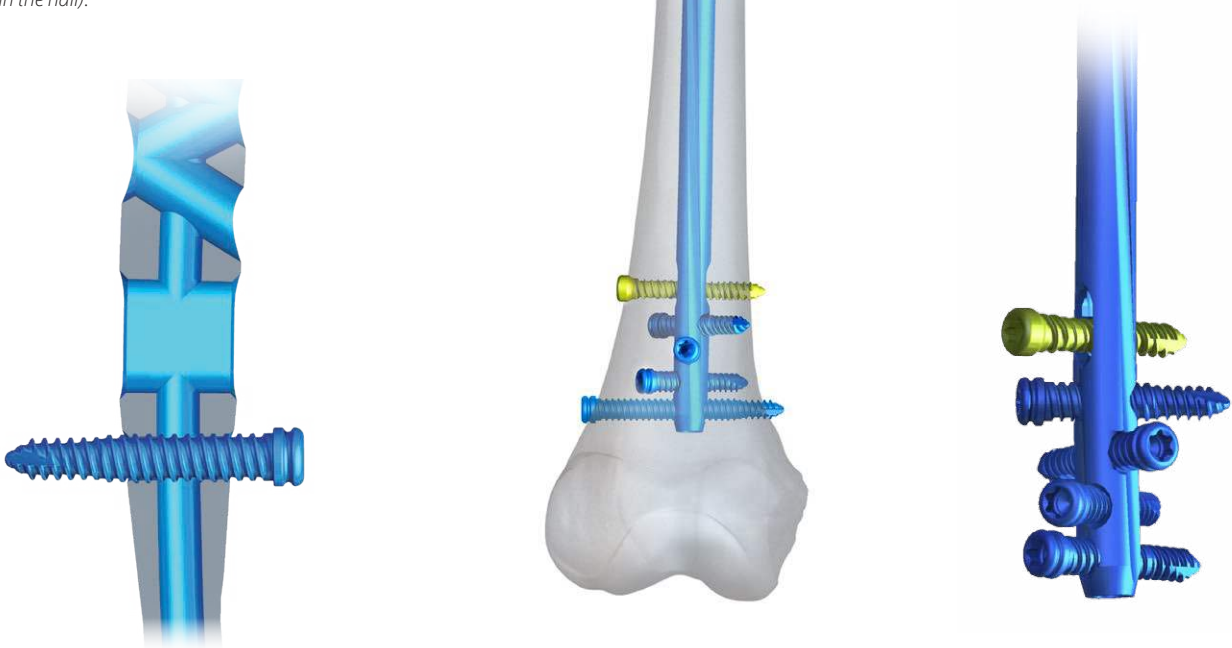

**The diameter of the intramedullary nail**

	Ø9 mm		Ø10 mm and greater	
	Standard locking	Locking with angular stabilization	Standard locking	Locking with angular stabilization
<b>Round hole</b> 	<b>CHARFIX2</b> Distal screw 4.0 <i>(turquoise)</i> 	<b>CHARFIX2</b> Distal screw 4.5 <i>(brown)</i> 	<b>CHARFIX2</b> Distal screw 5.0 <i>(gold)</i> 	<b>CHARFIX2</b> Distal screw 5.5 <i>(blue)</i> 
<b>Oval-shaped hole</b> 	<b>CHARFIX2</b> Distal screw 4.0 <i>(turquoise)</i> 		<b>CHARFIX2</b> Distal screw 5.0 <i>(gold)</i> 	

III. IMPLANTS

CHARFIX2 ANATOMICAL FEMORAL NAIL SHORT

**CHARFIX** *system 2*

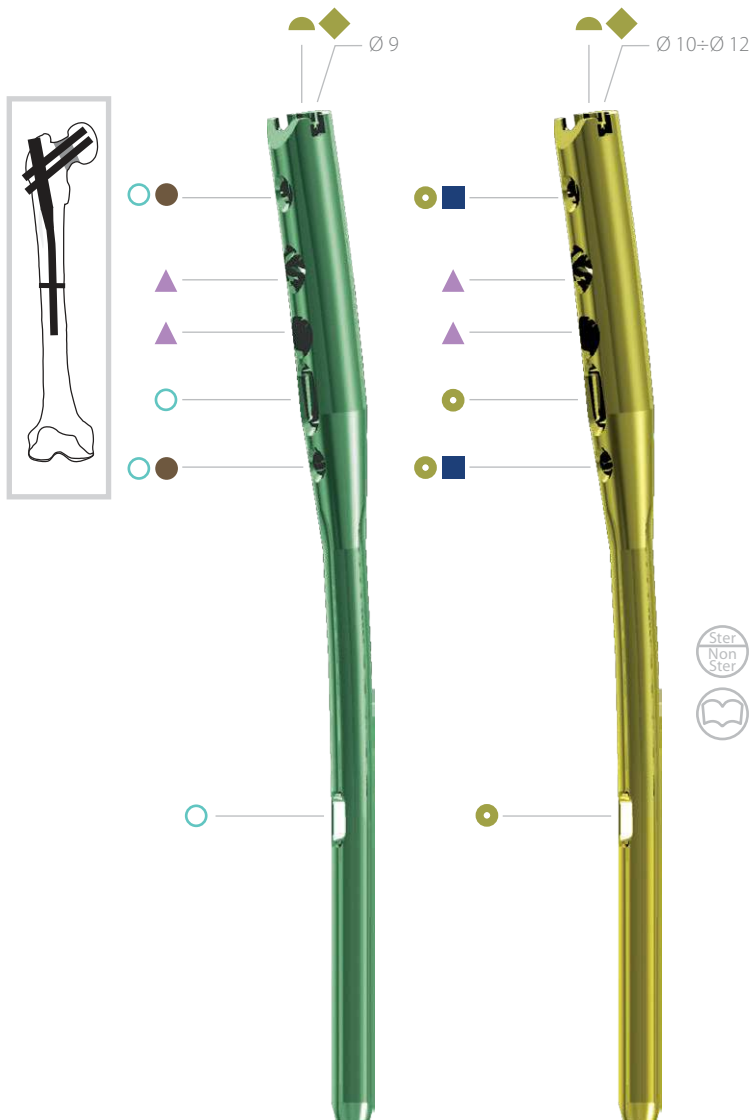

	Len	Ti
9	180	3.5177.180
	200	3.5177.200
10	180	3.5178.180
	200	3.5178.200
11	180	3.5179.180
	200	3.5179.200
12	180	3.5180.180
	200	3.5180.200

available	Ø	10 mm ±12 mm	pitch	1 mm
	L	180 mm ± 240 mm		5 mm



	Ti					
	3.5168.xxx	✓		✓	7.5	50÷120
	3.5160.xxx	✓	✓		5.5	30÷90
	3.5159.xxx	✓			5.0	30÷90
	3.5170.xxx	✓	✓		4.5	30÷90
	3.5169.xxx	✓			4.0	30÷90
	3.5162.000	✓				
	3.5161.xxx	✓		✓		0÷15

CHARFIX2 ANATOMICAL FEMORAL NAIL

CHARFIX system 2

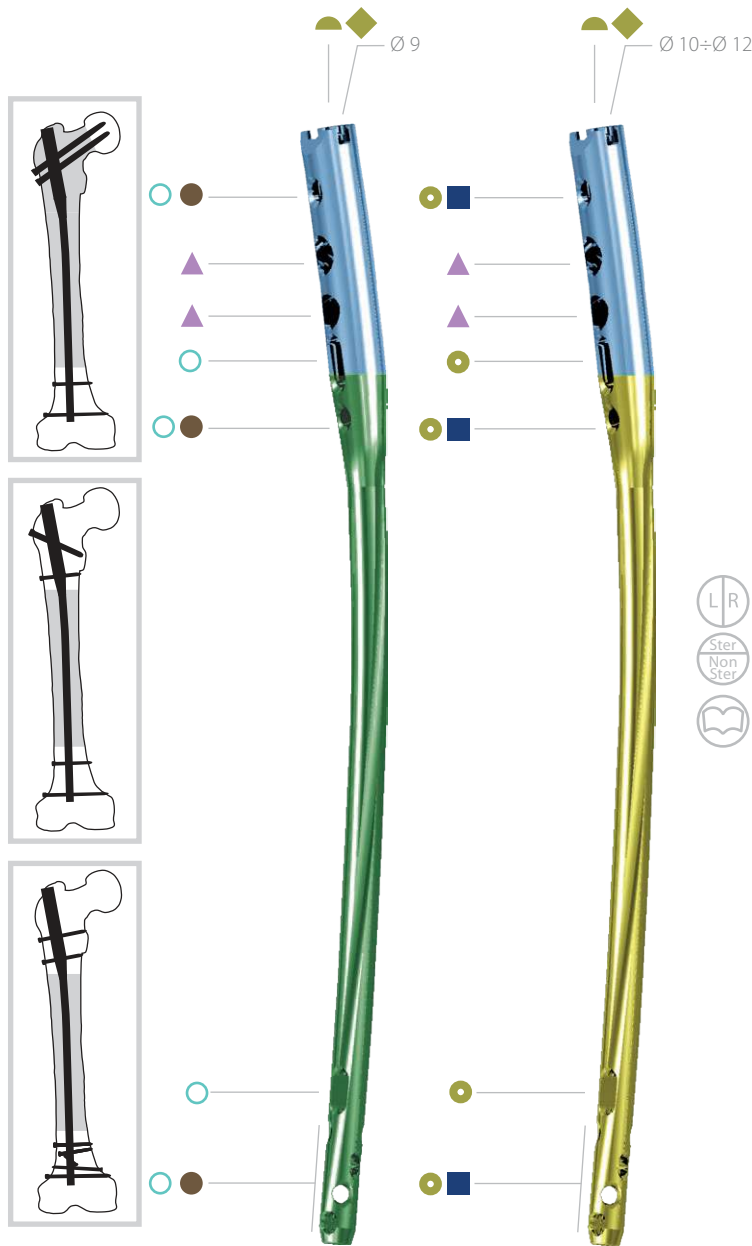

	Len	L	R
9	340	3.5103.340	3.5104.340
	360	3.5103.360	3.5104.360
	380	3.5103.380	3.5104.380
	400	3.5103.400	3.5104.400
	420	3.5103.420	3.5104.420
	440	3.5103.440	3.5104.440
	460	3.5103.460	3.5104.460
10	340	3.5105.340	3.5106.340
	360	3.5105.360	3.5106.360
	380	3.5105.380	3.5106.380
	400	3.5105.400	3.5106.400
	420	3.5105.420	3.5106.420
	440	3.5105.440	3.5106.440
	460	3.5105.460	3.5106.460
11	340	3.5107.340	3.5108.340
	360	3.5107.360	3.5108.360
	380	3.5107.380	3.5108.380
	400	3.5107.400	3.5108.400
	420	3.5107.420	3.5108.420
	440	3.5107.440	3.5108.440
	460	3.5107.460	3.5108.460
12	340	3.5109.340	3.5110.340
	360	3.5109.360	3.5110.360
	380	3.5109.380	3.5110.380
	400	3.5109.400	3.5110.400
	420	3.5109.420	3.5110.420
	440	3.5109.440	3.5110.440
	460	3.5109.460	3.5110.460

available		Ø	10 mm ±14 mm	pitch	1 mm
		L	280 mm ÷ 600 mm		5 mm

	Ti						
3.5168.xxx	✓			✓	7.5	50÷120	
3.5160.xxx	✓	✓			5.5	30÷90	
3.5159.xxx	✓				5.0	30÷90	
3.5170.xxx	✓	✓			4.5	30÷90	
3.5169.xxx	✓				4.0	30÷90	
3.5162.000	✓						
3.5161.xxx	✓		✓		0÷15		

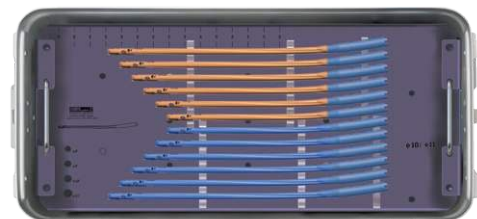

Stand for anatomical femoral nails (set with a box without implants) 40.5752.000

LOCKING ELEMENTS



CHARFIX2 DISTAL SCREW 5.0



30	3.5159.030
35	3.5159.035
40	3.5159.040
45	3.5159.045
50	3.5159.050
55	3.5159.055
60	3.5159.060
65	3.5159.065
70	3.5159.070
75	3.5159.075
80	3.5159.080
85	3.5159.085
90	3.5159.090



CHARFIX2 DISTAL SCREW 5.5



30	3.5160.030
35	3.5160.035
40	3.5160.040
45	3.5160.045
50	3.5160.050
55	3.5160.055
60	3.5160.060
65	3.5160.065
70	3.5160.070
75	3.5160.075
80	3.5160.080
85	3.5160.085
90	3.5160.090



CHARFIX2 RECONSTRUCTION CANNULATED SCREW 7.5



50	3.5168.050
55	3.5168.055
60	3.5168.060
65	3.5168.065
70	3.5168.070
75	3.5168.075
80	3.5168.080
85	3.5168.085
90	3.5168.090
95	3.5168.095
100	3.5168.100
105	3.5168.105
110	3.5168.110
115	3.5168.115
120	3.5168.120

CHARFIX2 DISTAL SCREW 4.0



30	3.5169.030
35	3.5169.035
40	3.5169.040
45	3.5169.045
50	3.5169.050
55	3.5169.055
60	3.5169.060
65	3.5169.065
70	3.5169.070
75	3.5169.075
80	3.5169.080
85	3.5169.085
90	3.5169.090



CHARFIX2 DISTAL SCREW 4.5



30	3.5170.030
35	3.5170.035
40	3.5170.040
45	3.5170.045
50	3.5170.050
55	3.5170.055
60	3.5170.060
65	3.5170.065
70	3.5170.070
75	3.5170.075
80	3.5170.080
85	3.5170.085
90	3.5170.090



CHARFIX2 END CAP M10X1.5

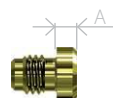

A	
0	3.5161.700
+5	3.5161.705
+10	3.5161.710
+15	3.5161.715

CHARFIX2 COMPRESSION SCREW M10X1.5



3.5162.000
------------























Stand for CHARFIX2 nail locking elements (set with a box without implants)





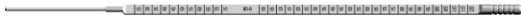



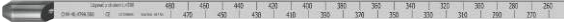



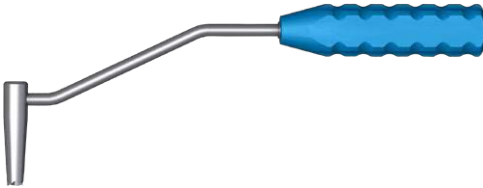



40.5058.200

## IV. INSTRUMENT SET

Instrument set **[40.5500.500]** is used to perform fixation of bone fragments of trochanteric and shaft part of femur and to remove implants after finished treatment. Instruments are placed on the stand and covered with its lid, so storage and transportation for operating suite is facilitated.

Instrument set consists of the following instruments:

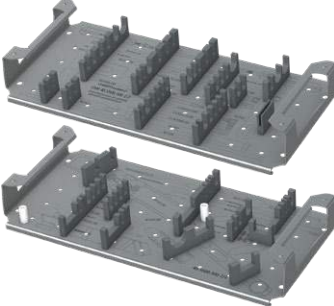
INSTRUMENT SET FOR ANATOMICAL FEMORAL NAILS 40.5500.500	Name	Pcs	Catalogue No.
	Targeter arm	1	40.5501.000
	Targeter B	1	40.5502.100
	Targeter D	1	40.5503.300
	Connecting screw M10x1.5 L=53	1	40.5504.000
	Impactor-extractor	1	40.5507.000
	Guide 9/2.8	1	40.5508.200
	Set block 9/5.0	2	40.5509.100
	Trocar 9	1	40.3327.100
	Protective guide 11/9	2	40.3328.200
	Protective guide 9/7	2	40.5510.200
	Drill guide 7/3.5	2	40.5511.200
	Connector M10x1.5/M12	1	40.5512.000
	Gradual cannulated drill 7.5/2.8	1	40.5513.200
	Compression screw	1	40.5517.000
	Curved awl 8.0	1	40.5523.000
	Wrench S10	1	40.5526.100
	Guide rod handle	1	40.1351.000
	Screw length measure	1	40.5530.100
	Guide rod 2.8/385	4	40.5531.000
	Guide rod 3.0/580	1	40.3925.580
	Drill with scale 3.5/350	2	40.5339.002
	Nail length measure	1	40.4798.500

INSTRUMENT SET FOR ANATOMICAL FEMORAL NAILS 40.5500.500	Name	Pcs	Catalogue No.
	Cannulated screwdriver T30	1	40.5574.300
	Screwdriver T25	1	40.5575.300
	Targeter D	1	40.1344.100
	Drill guide short 7/3.5	1	40.1358.100
	Trocar short 7 Троакар короткий 7	1	40.1354.100
	Trocar 6.5	1	40.5534.100
	Cannulated screw length measure	1	40.4724.100
	Mallet	1	40.3667.000
	Teflon pipe guide	1	40.1348.000
	Aiming insert 9.0	2	40.5065.009
	Aiming insert 11.0	2	40.5065.011
	Protective guide 17/14	1	40.5518.100
	Cannulated drill 14/3,5	1	40.5515.100
	Perforated aluminum lid 1/1 595x275x15mm Gray	1	12.0750.200
	Stand for instr. set of anatomical femoral nails	1	40.5519.500
	Container with solid bottom 1/1 595x275x185mm	1	12.0750.103



## V. SURGICAL TECHNIQUE

---



**NOTE:** The following description includes main steps of procedure during implantation of intramedullary anatomical femoral nails, however it does not comprise a detailed instruction of conduct. The surgeon decides on choosing the surgical technique and its application in every individual case.

---

### V.1. PLANNING THE PROCEDURE

Every surgical procedure should be properly planned. It is necessary to perform X-Ray imaging of whole femur with adjacent joints in ap and lateral plane as to avoid missing its damage in proximal and distal part. It is especially important while nailing the pathological fractures of subtrochanteric area.

Special attention should be paid to coexisting femoral neck fractures and comminuted fractures of proximal epiphysis of femur, and also to the possibility of their occurrence during nail insertion.

Further fragmentation of main fragments may occur during procedure. Dynamic fixation must be replaced with static fixation in such cases.

Attention should be also paid to hip joint condition. In serious arthrosis or contraction nailing can be very difficult, or even impossible.

Procedure should be performed on traction table with a patient positioned supine or in lateral position.

Advantage of lateral position is easier access to the greater trochanter which is especially important in obese patients. In supine position access to the greater trochanter is more difficult, however further phases of procedure (*especially correction of rotational displacement*) are definitely easier.

If a patient cannot be operated at the day of femur injury, it is recommended to retract the fragments through application of very strong traction for 2-3 days. This will facilitate further reduction and insertion of the nail significantly.

Patient positioning on operating table is an integral part of surgical procedure. Intramedullary osteosynthesis with presented method requires intraoperative imaging.

## V.2. PATIENT POSITIONING

In presented method of intramedullary osteosynthesis of femur with anatomical femoral nail, a supine patient position is recommended [Fig.1.]. To increase access to greater trochanter, the patient's body shall be bent in the opposite direction to fracture. If the access is still insufficient, the fractured leg shall be adducted. The limb adduction shall be reduce before the nail implantation, in order to obtain adequate fragments' position.

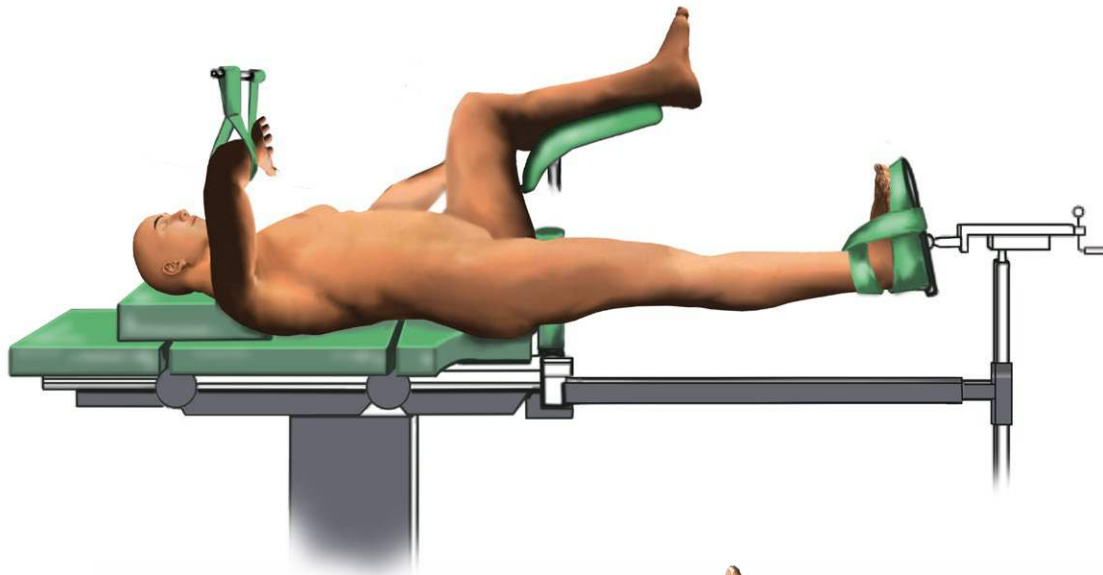
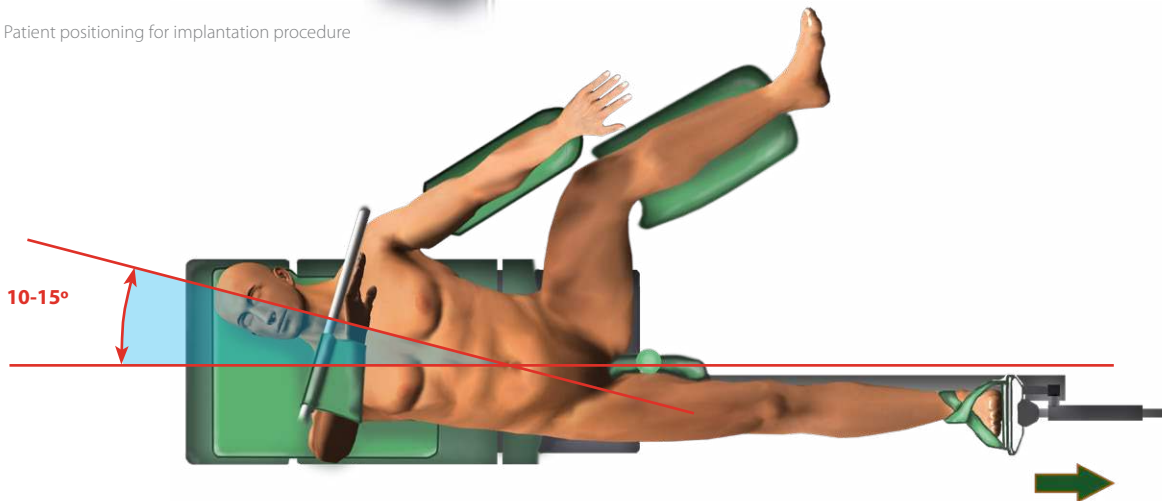

Fig. 1. Patient positioning for implantation procedure



## V.3. REDUCTION OF FRACTURE

Fracture reduction should be performed before implantation, according to surgical technique adequate for fracture being reduced.



Orthopedic surgeon decides on fragments reduction method. It is recommended to aim at anatomical positioning of fragments during repositioning.

## V.4. SURGICAL APPROACH

The procedure can be performed with use of intraoperative image intensifier with C-arm. C-arm of X-Ray unit should be placed laterally to the patient, in a way ensuring precise imaging in AP and lateral position [Fig. 2.].

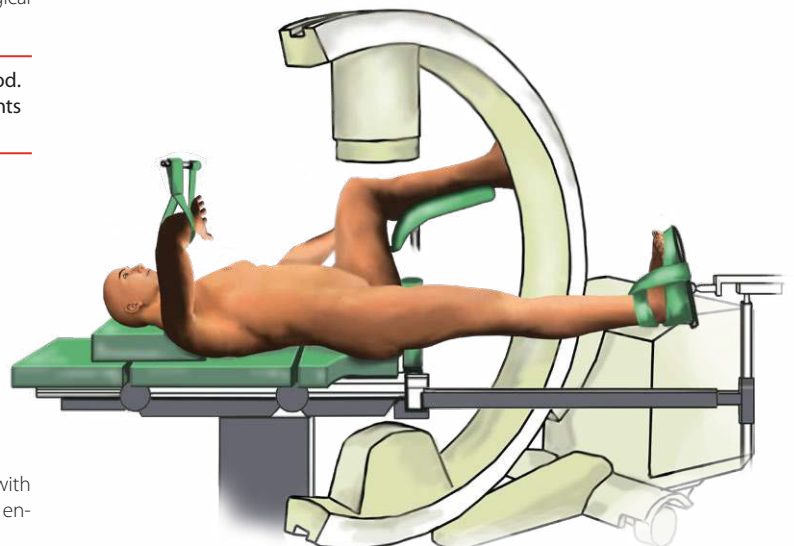

Fig. 2. Positioning of intraoperative X-Ray unit with C-arm

Watson-Jones lateral approach is recommended. Palpate the greater trochanter. Then, perform 3÷5 cm lateral incision at the distance of 2÷6 cm from tip of the greater trochanter, in line with medullary canal axis [Fig. 3]. The incision should be extended in obese patients.

When the fascia is reached, cut it along the skin incision line. Next the dissection of gluteus maximus muscle fibres should be performed.

Back from gluteus medius muscle, approach to the greater trochanter apex is enabled.



Fig.3. Determination of incision site

## V.5. ENTRY POINT

In AP plane, entry point is located at line angled from medullary canal axis of about 10°, at level of fossa trochanterica. In lateral plane, entry point is in line with the axis of the medullary canal [Fig. 4].

Having localized the nail entry point, using the drive, insert the guide rod 2.8/385 [40.5531] into the medullary canal. Precise guide rod introduction ensures proper nail implantation.

The surgeon determines length and diameter of the nail on the basis of injured femur X-Ray and X-Ray of opposite intact femur.

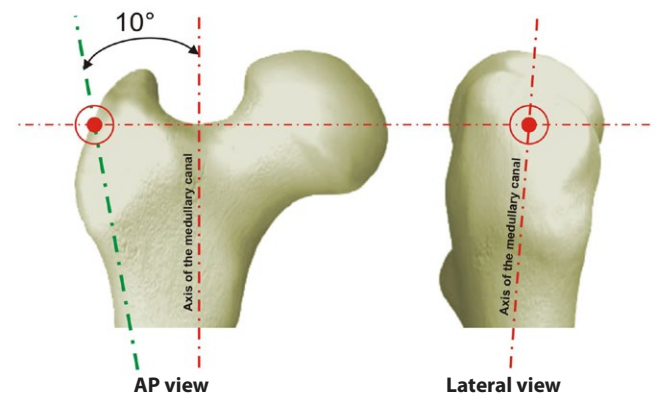

Fig. 4. Entry point



40.5531

## V.6. OPENING AND PREPARATION OF MEDULLARY CANAL AND NAIL INSERTION

### V.6.1. Opening and preparation of medullary canal for nail insertion

**1** Using guide rod 2.8/385 [40.5531], insert into the medullary canal curved awl 8.0 [40.5523] to the depth at which the awl blade goes along the medullary canal, allowing proper insertion of guide rod 3.0/580 [40.3925.580]. Having opened medullary canal, remove guide rod 2.8/385 [40.5531]. Mount guide rod 3.0/580 [40.3925.580] to guide rod handle [40.1351] and enter the guide into the medullary canal through curved awl 8.0 [40.5523] cannulated hole to the depth required for the proper fixation of bone fragments. While guide rod insertion, control the fracture reduction and make sure the guide rod passes through all the bone fragments.

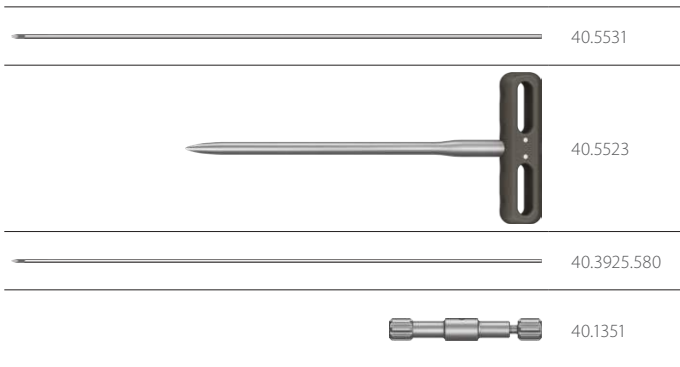

**2** Remove guide rod handle [40.1351] and curved awl 8.0 [40.5523]. Leave guide rod 3.0/580 [40.3925.580] in place. Open the medullary canal using cannulated drill 14/3.5 [40.5515.100] inserted into protective guide 17/14 [40.5518.100] via guide rod 3.0/580 [40.3925.580]. Slowly ream the medullary canal using cannulated drill until it rests on the protective guide. Remove protective guide, cannulated drill.



The process shall be controlled with X-Ray.

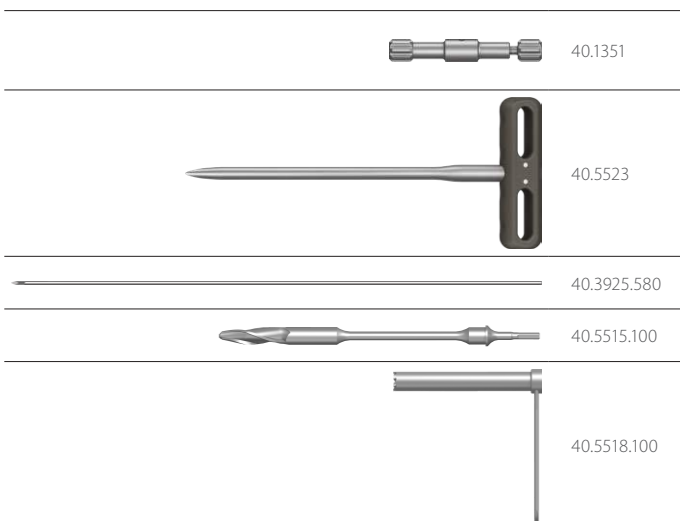

- 3 In case nail implantation is preceded with reaming the medullary canal, the canal should be gradually enlarged with flexible reamers guided over the guide rod 3.0/580 [40.3925.580]. Reaming should begin with Ø8 mm reamer and should continue with 0.5 mm diameter graduation until a hole 1.5÷2 mm greater than nail diameter, with depth not lesser than nail length is achieved. Whether the medullary canal of femur shaft is reamed or not, the proximal part of the medullary canal should be reamed to a diameter of 15 mm to a depth of about 9 cm.  
Remove flexible reamer.



In case of using a reamer guide (*guide rod*) other than the one included in the instrument set [40.5500.500], use the teflon pipe guide [40.1348] (*white teflon pipe*) to ream the intramedullary canal and follow the steps of given instruction.



- 4 Introduce the teflon pipe guide [40.1348] over the flexible reamer guide (*guide rod*) deep into the medullary canal, until the end of reamed canal in distal part of femur is reached.

Remove the flexible reamer guide (*guide rod*).

Mount the guide rod 3.0/580 [40.3925.580] in guide rod handle [40.1351] and introduce entire construction into the medullary canal, through the teflon pipe guide, until the end of reamed canal in distal part of femur is reached. Detach the guide rod handle [40.1351] of the guide rod. Remove the teflon pipe guide [40.1348] from the medullary canal, leave the guide rod.



- 5 Introduce the nail length measure **[40.4798.500]** via the guide rod until it reaches the bone. Read the nail length from the scale. Remove the nail length measure from the guide rod. The medullary canal is prepared for nail insertion.



## V.6.2. Connecting the nail with targeter arm and determination of targeter D slider position



Targeter D [40.5503.300] cannot be used with short anatomical femoral nails. In this case, step 6.2 shall be omitted.

6

Targeter D [40.5503.300] has a targeting slider and a screw for targeter arm [40.5501] attachment, reversed regarding operating site before attaching targeter arm.

**If both targeters are connected correctly, the reading planes of RIGHT or LEFT sign should be compatible.**

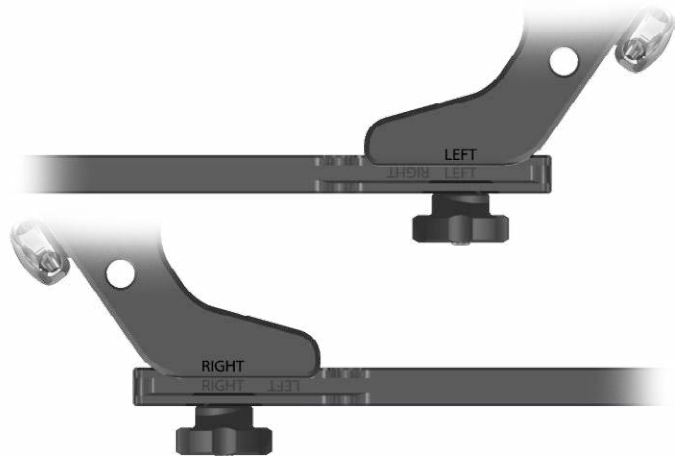

7



**NOTE!** The screw joining targeter D with targeter arm shall always be placed outside the targeter (*in relation to the nail*). In order to reverse the screw, pull the knob, what will result in system decoupling. Then the screw should be reversed for suitable site and pressed into the targeter hole. Specific "click" determines correct system connection. Slider of targeter D should be always placed in such a way as to make its fixation possible at external site (*in relation to the nail*) using T25 screwdriver. Moreover, the setting of the screw knob should always be directed upward.

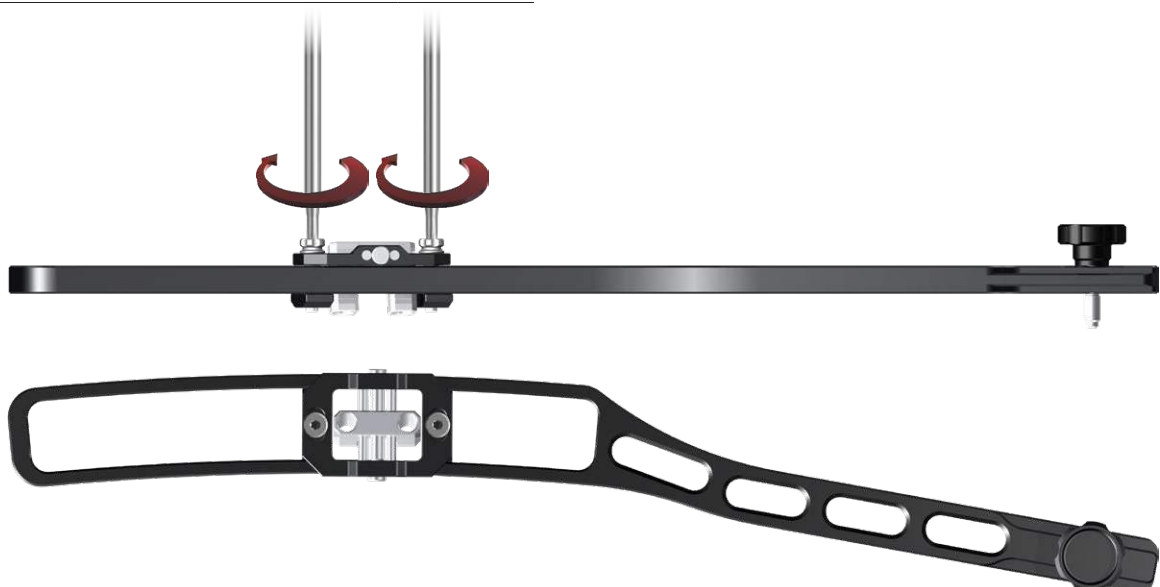

- 8 Mount the selected nail to the targeter arm **[40.5501]** using connecting screw M10x1.5 L=55 **[40.5504]** inserted by wrench S10 **[40.5526.100]**. Attach the targeter D **[40.5503.300]** to the targeter arm, in accordance with steps 6 and 7.



40.5504



40.5501



40.5526.100



40.5503.300



- 9 Loosen the slider's setting screws (in order to allow movement of the slider along the targeter D beam) and shift the slider close to the holes in distal part of the nail.



40.5503.300

- 10 Set the correct slider position in relation to the holes in distal part of the nail using two set blocks 9/5.0 **[40.5509.100]**. Fix slider position using the screwdriver T25 **[40.5575.300]**.



**Check:** slider is set and fixed correctly if the set blocks hit smoothly in the holes of the nail.

Remove the set blocks from the targeter slider.  
Detach the targeter D of the targeter arm.



40.5503.300



40.5509.100



40.5575.300

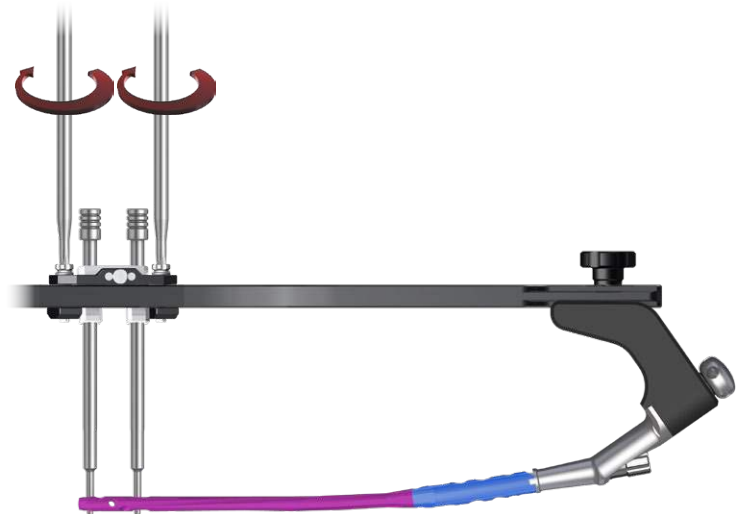



### V.6.3. Nail insertion into the medullary canal

11 Join the targeter arm [40.5501] with impactor-extractor [40.5507].



**NOTE!** In order to connect targeter arm with impactor-extractor, remove the mallet screw from the targeter arm.

Position the system in plane perpendicular to the AP plane and introduce the nail into the medullary canal using mallet [40.3667]. While introducing, the nail rotates and moves along the medullary canal. In the end phase of insertion, targeter arm rotates with the nail at 90° from the initial position.



40.5501



40.5507



40.3667



**NOTE!** If the nail did not move from anterior to lateral position, then it should be removed from medullary canal and reinserted, with targeter rotated a few degrees laterally in relation to AP plane.

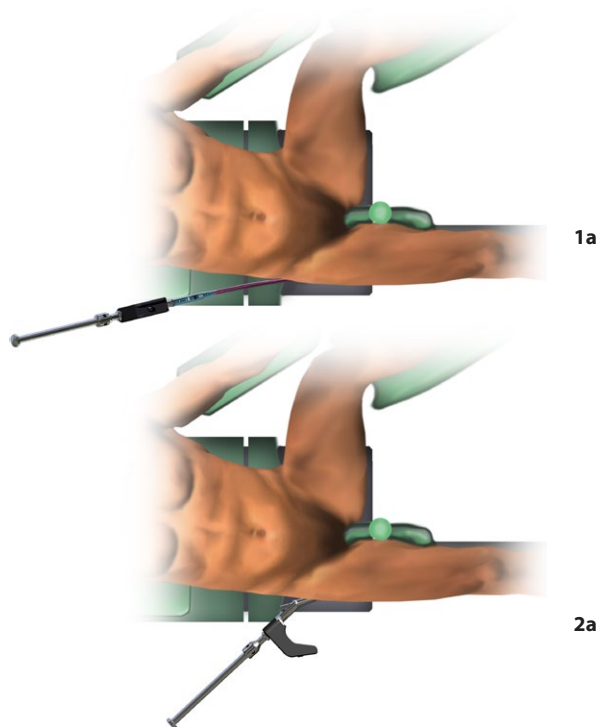
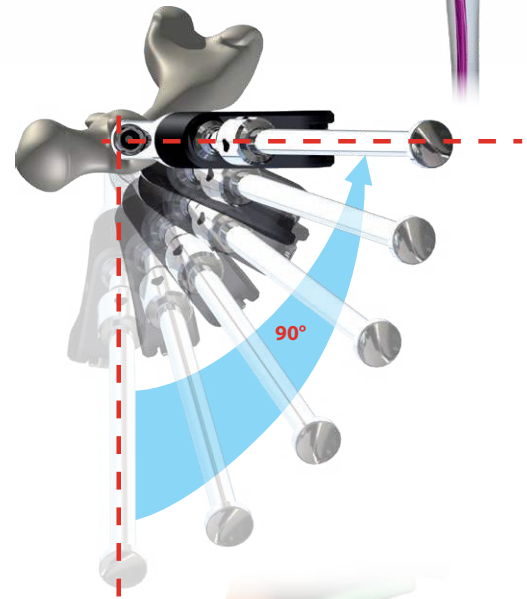

1a

2a

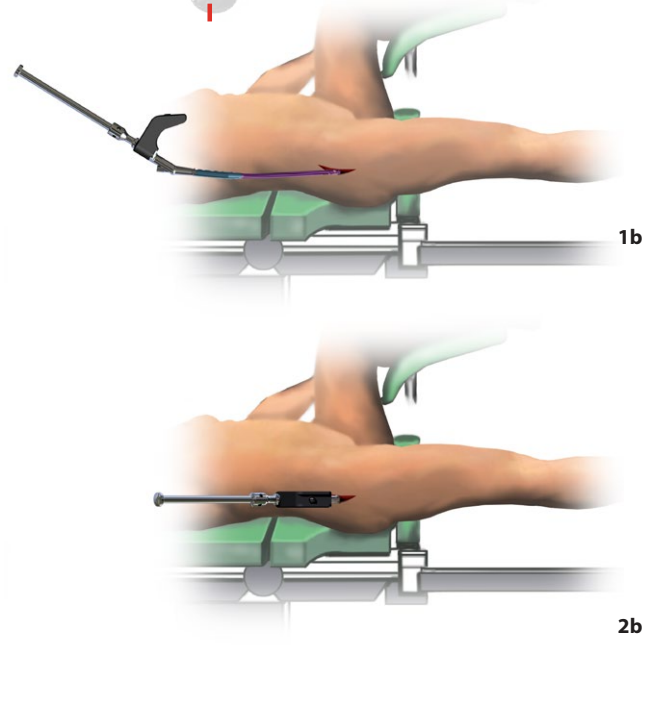

1b

2b

Remove the guide rod [40.3925.580].  
Detach the impactor-extractor [40.5507] of the targeter arm [40.5501].

40.3925.580

- 12 Correctness of nail penetration inside femur can be checked using guide rod 2.8/385 [40.5531] introduced in targeter B [40.5502.100] hole marked "0".

Attach targeter B [40.5502.100] to the targeter arm [40.5501], then introduce guide rod 2.8/385 [40.5531] in hole marked "0". End of the rod will point the proximal end of the nail. If necessity of deeper nail insertion occurs, the depth of insertion can be determined using other holes prepared for guide rods (*introducing guide rods in holes marked "5" ÷ "15" and taking the X-Ray*). Then select the suitable height of the end cap in order to protect the nail against bone overgrowth.

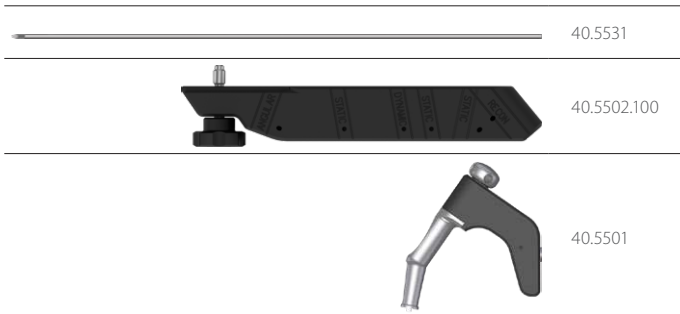

## V.7. LOCKING THE NAIL

### V.7.1. Reconstruction method

#### V.7.1.1. Locking the nail with reconstruction cannulated screws in proximal part



**NOTE!** In reconstruction method the nail should be always locked with two reconstruction screws.

- 13 Introduce protective guide 11/9 [40.3328.200] together with trocar 9 [40.3327.100] in the most distal reconstruction (RECON) hole of targeter B [40.5502.100].

After marking the screw's entry point on the skin, perform incision of soft tissues. Trocar should penetrate to the cortex and mark the entry point for the drill. The protective guide should penetrate together with the trocar until reaching the bone.

Remove the trocar.  
Leave the protective guide inside the targeter hole.

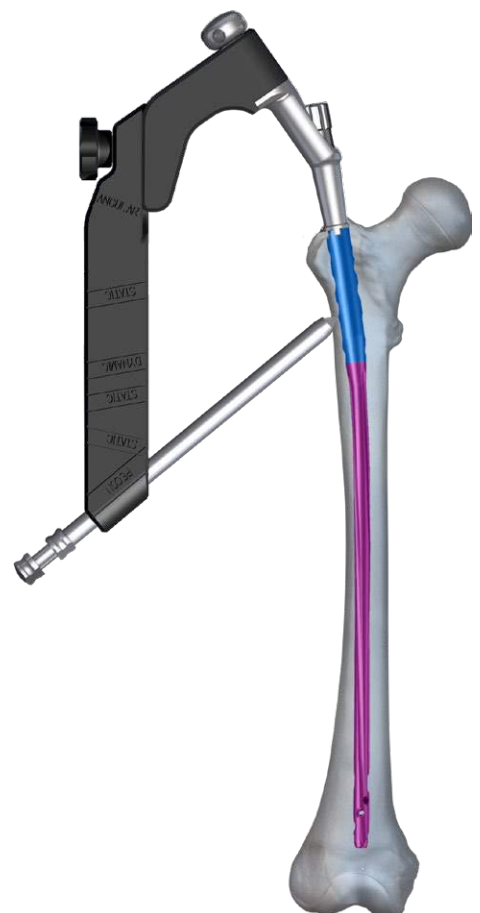
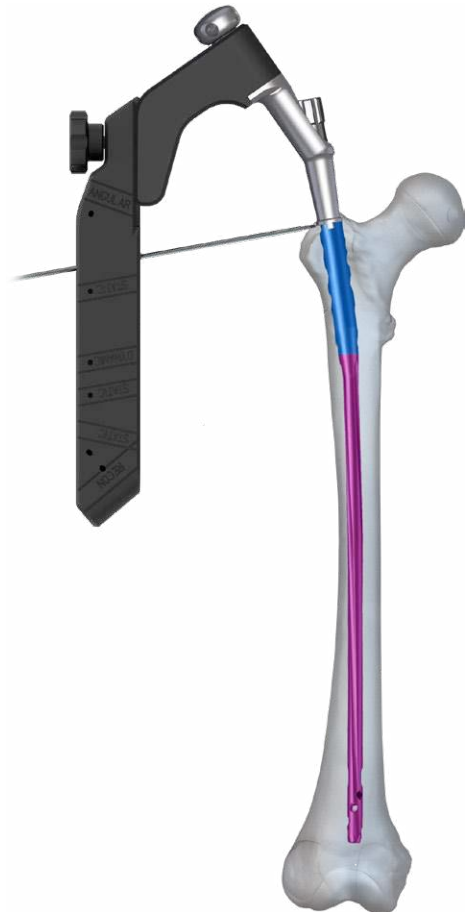
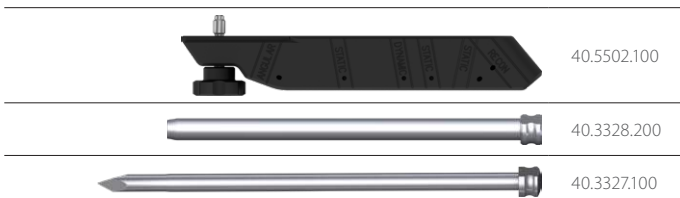

- 14 Introduce guide 9/2.8 [40.5508.200] into protective guide [40.3328.200].

Mount the guide rod 2.8/385 [40.5531] in the drive.  
 Drill in the femoral neck with guide rod led in guide 9/2.8, so as not to perforate the cortex of femoral neck and head.

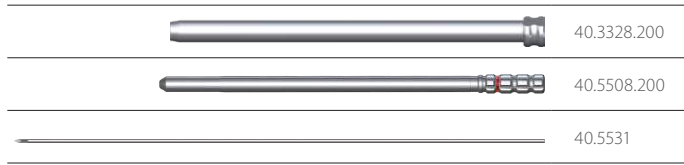

**NOTE!** Described operations should be performed under the X-Ray image intensifier control in AP projection. Check the guide rod position in femoral neck in lateral projection. Its position should ensure reconstruction screw introduction without femoral neck cortex infringement. Repeat the operation should the incorrect guide rod introduction occur.

Leave the guide rod 2.8/385, guide 9/2.8 and protective guide 11/9 in the targeter hole.



- 15 Introduce cannulated screw length measure [40.4724.100] onto guide rod introduced in femoral neck, in way that its tapered end contact with protective guide. Read length of reconstruction cannulated screw from the measure's scale, that is pointed by end of guide rod. Guide 9/2.8 [40.5508.200] should be in contact with cortical bone during the measurement.

Remove the cannulated screw length measure [40.4724.100] and guide 9/2.8 [40.5508.200].  
 Leave the guide rod.

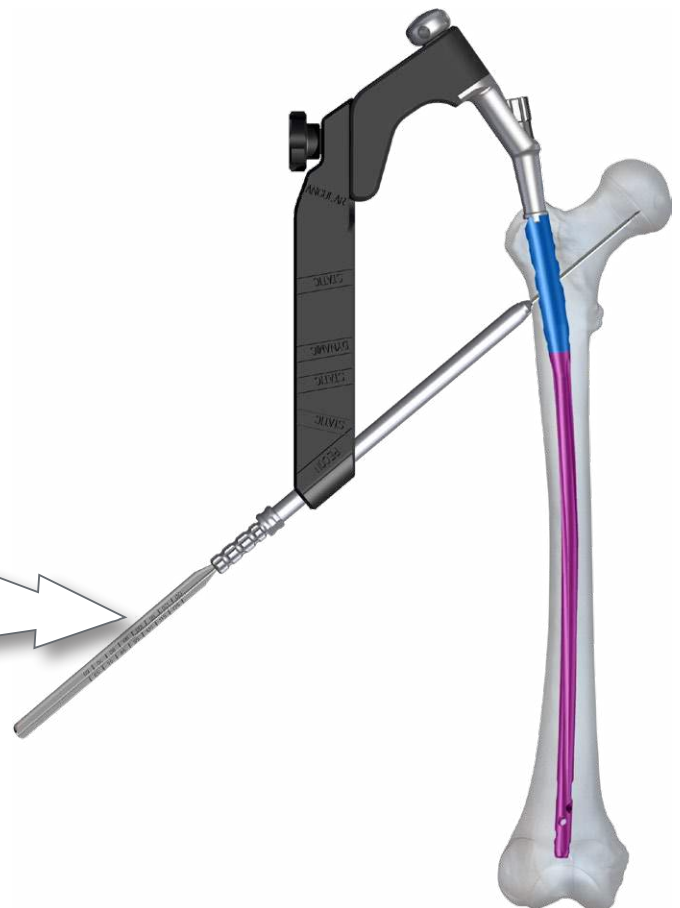
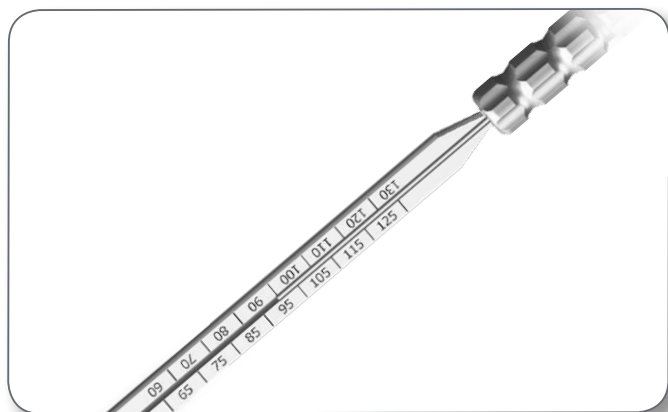
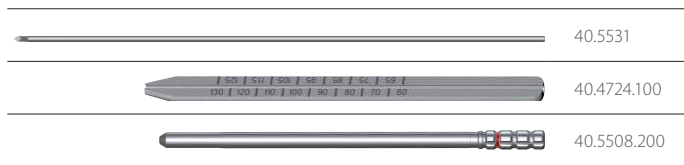

- 16** Introduce protective guide 11/9 [40.3328.200] together with trocar 9 [40.3327.100] in proximal reconstruction (RECON) hole of targeter B [40.5502.100].

After marking the screw's entry point on the skin, perform incision of soft tissues. Trocar should penetrate to the cortex and mark the entry point for the drill. The protective guide should penetrate together with the trocar until contact with the bone occurs.

Remove the trocar.

Leave the protective guide inside the targeter hole.



40.5502.100



40.3328.200



40.3327.100

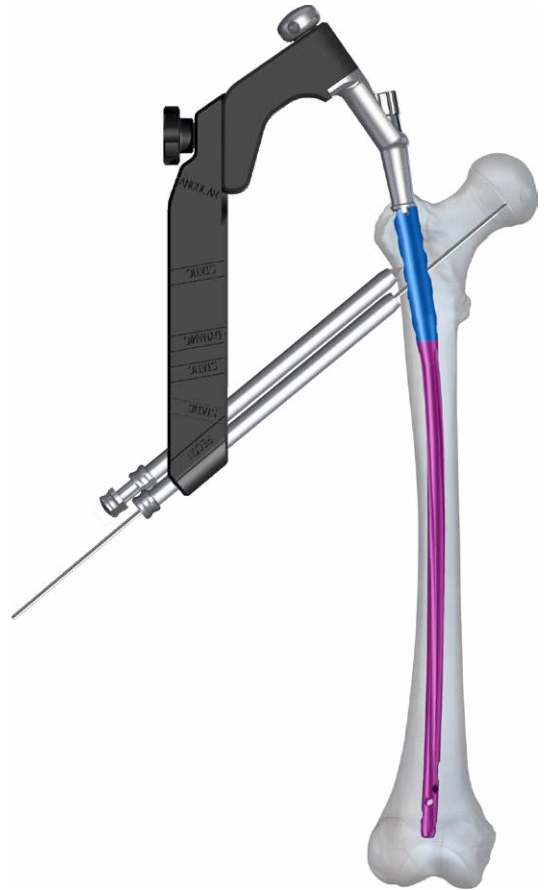
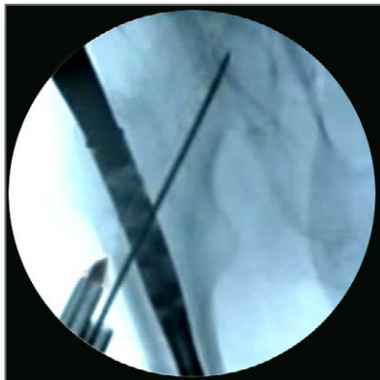

- 17** Introduce guide 9/2.8 [40.5508.200] into protective guide [40.3328.200].

Mount the guide rod 2.8/385 [40.5531] in the drive.

Drill in the femoral neck with guide rod led in guide 9/2.8, so as not to perforate the cortex of femoral neck and head.



Described operations should be performed under the X-Ray image intensifier control in AP projection. Check the guide rod position in femoral neck in lateral projection. Its position should ensure reconstructive screw introduction without femoral neck cortex infringement.

Repeat the operation in the case of incorrect guide rod introduction.

Leave the guide rod 2.8/385, guide 9/2.8 and protective guide 11/9 in targeter hole.



40.3328.200



40.5508.200



40.5531



**18** Introduce cannulated screw length measure [40.4724.100] onto guide rod introduced in femoral neck, in way that its tapered end contact with the protective guide. Read length of reconstruction cannulated screw from the measure's scale, that is pointed by end of guide rod. Guide 9/2.8 [40.5508.200] should be in contact with cortical bone during the measurement.

Remove the cannulated screw length measure [40.4724.100] and guide 9/2.8 [40.5508.200]. Leave the guide rod.

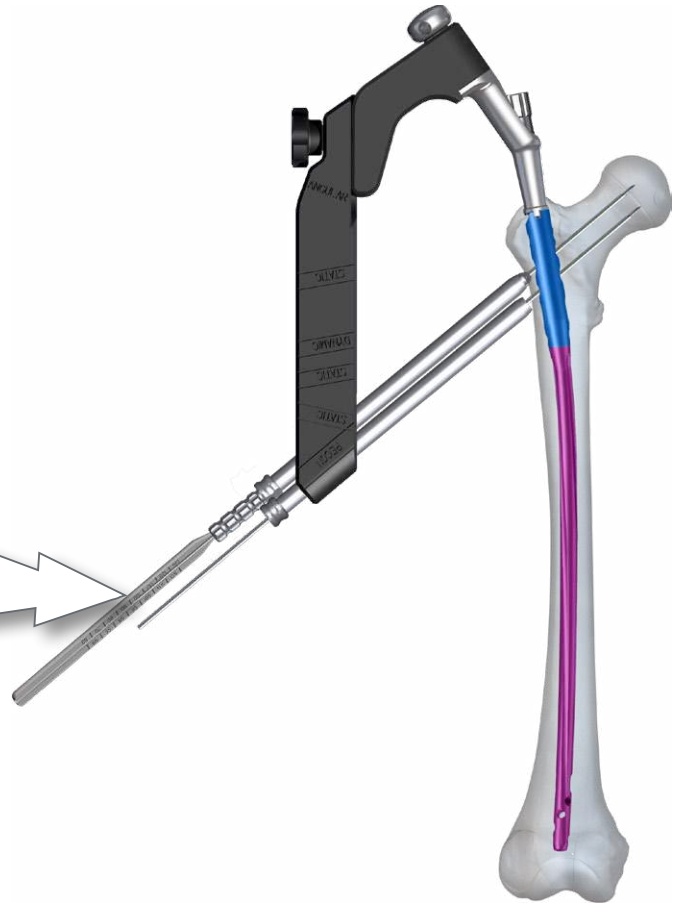
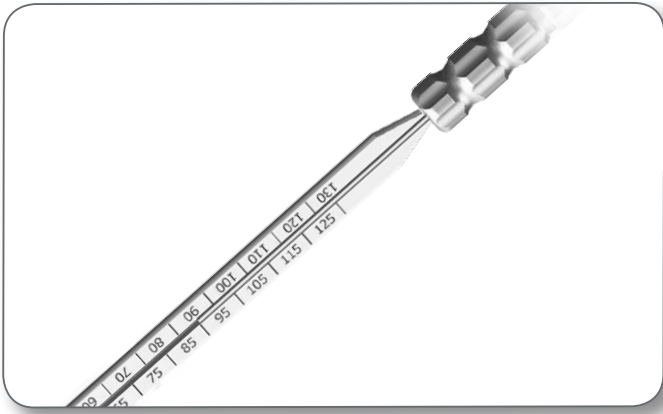
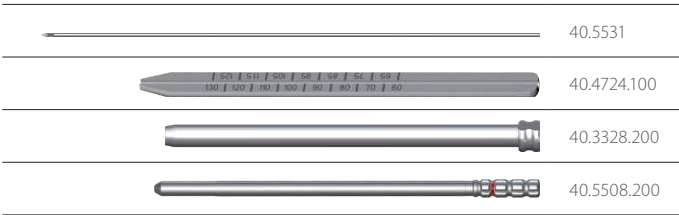

**19** Set the drilling depth, corresponding with length of selected reconstruction screw, on the gradual cannulated drill 7.5/2.8 [40.5513.200] using setting slider. Mount the gradual cannulated drill in the drive, then drill the hole until slider set on the drill leans against protective guide [40.3328.200], leading the drill over the guide rod and inside the protective guide [40.3328.200] (located in distal hole of the targeter).



Hole drilling should be performed under the X-Ray image intensifier control.

Remove the gradual cannulated drill. Leave the protective guide and guide rod inside the targeter hole.

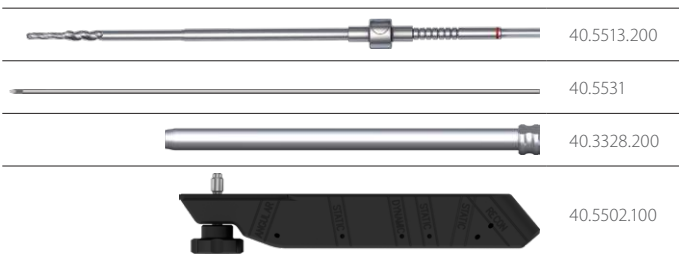

**20** Insert the tip of cannulated screwdriver T30 [40.5574.300] into the head of reconstruction cannulated screw with selected length (set on the gradual cannulated drill using setting slider or from measurement with cannulated screw length measure). Insert the set in protective guide [40.3328.200] and leading over the guide rod 2.8/385 [40.5531] drive in previously performed hole in femoral neck until the screw's head reaches the cortex (groove on the screwdriver's shaft meets with end of the protective guide).



Remove the cannulated screwdriver and guide rod from distal hole of the targeter. Guide rod 2.8/385 [40.5531] is a single use instrument.

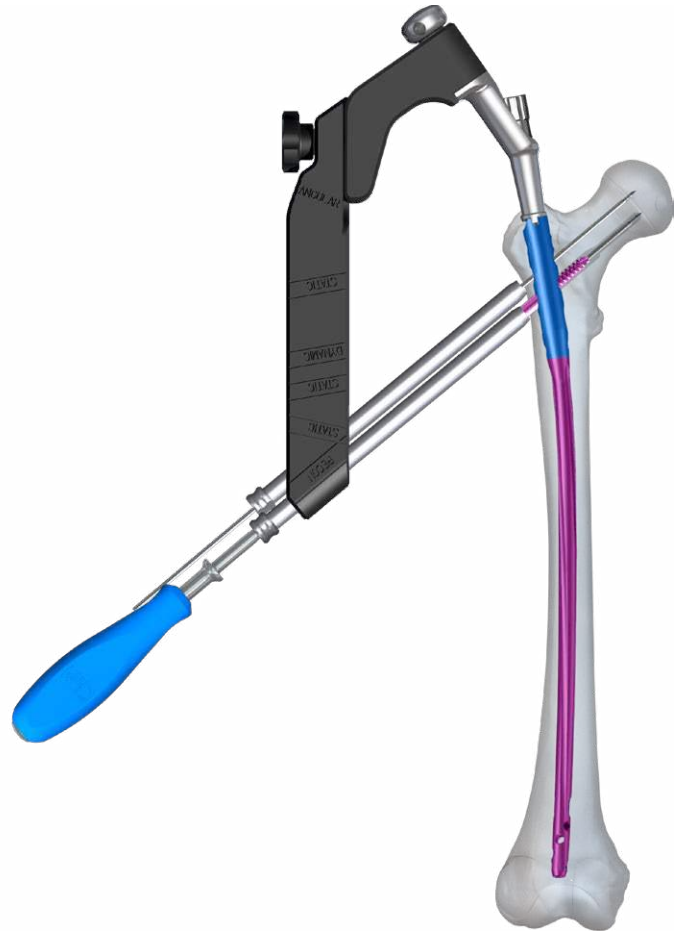
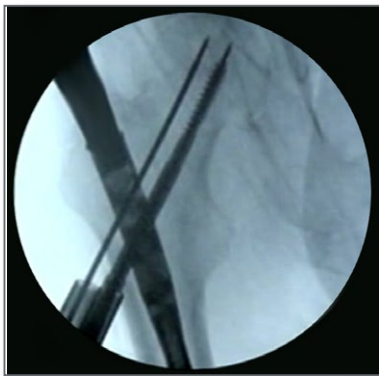
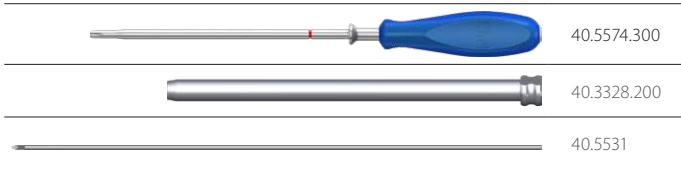

**21** Set the drilling depth, corresponding with length of selected reconstruction screw, on the gradual cannulated drill 7.5/2.8 [40.5513.200] using setting slider. Mount the gradual cannulated drill in the drive, then drill the hole until slider set on the drill leans against protective guide [40.3328.200], leading the drill over the guide rod and inside the protective guide [40.3328.200] (located in proximal hole of the targeter).



Hole drilling should be performed under the X-Ray image intensifier control.

Remove the gradual cannulated drill.  
Leave the protective guide and guide rod inside the target's hole.

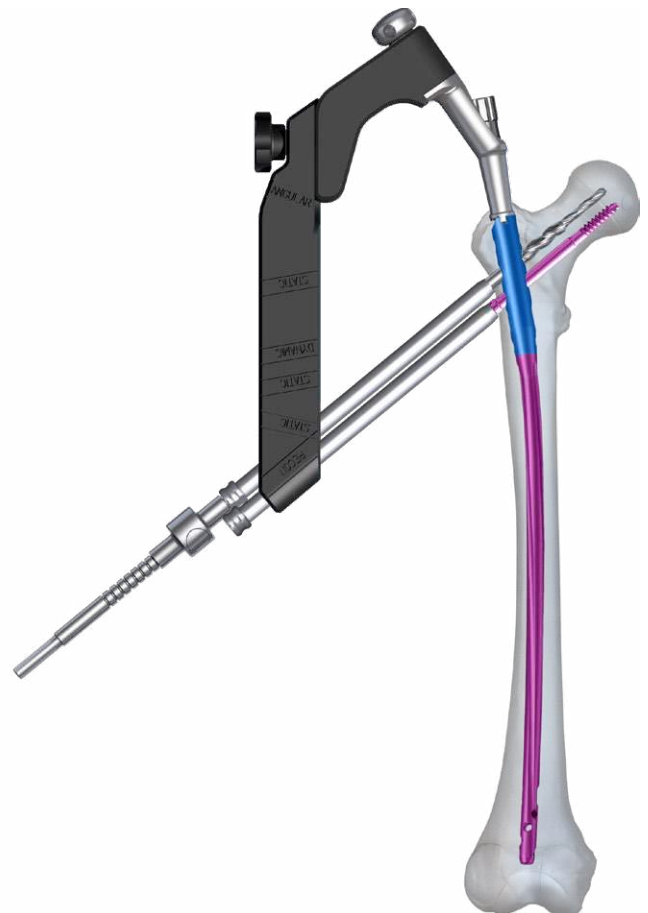
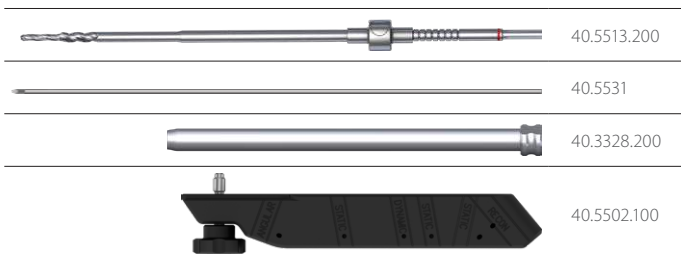

**22** Insert the tip of cannulated screwdriver T30 [40.5574.300] into the head of reconstruction screw with selected length (*set on the gradual cannulated drill using setting slider or from measurement with cannulated screw length measure*). Insert the set in protective guide [40.3328.200] and leading over the guide rod 2.8/385 [40.5531] drive in previously performed hole in femoral neck until the screw's head reach the cortex (*groove on the screwdriver's shaft meets with end of the protective guide*).



Remove the cannulated screwdriver and guide rod. Guide rod 2.8/385 [40.5531] is a single use instrument.

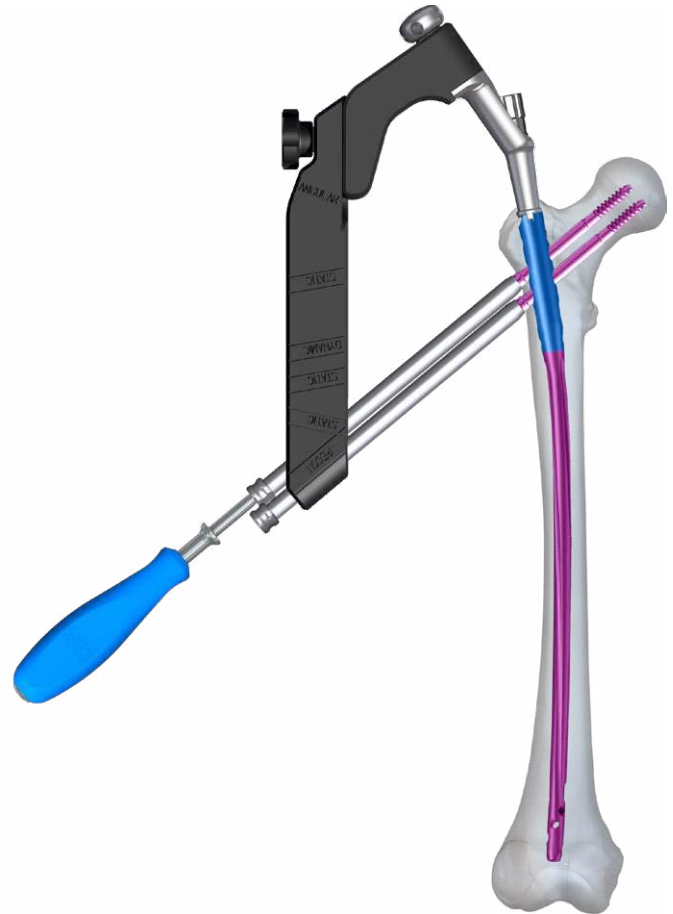
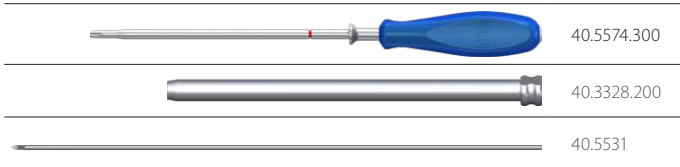

**23** Remove both protective guides 11/9 [40.3328.200] from reconstruction (RECON) holes in targeter B.



In the case of short nail application, leave targeter arm [40.5501] and targeter B [40.5502.100] coupled.

Correctness of performed fixation of femoral neck fracture should be verified by taking a X-Ray image in AP and lateral projection.



With small overall dimensions of targeter B additionally deflected with anteversion angle, it is possible to take a X-Ray image in lateral projection (*C-arm is then positioned under slight angle in relation to the targeter*). Radiographic image of nail with locking elements can be helpful while confirmation of correctness of performed locking.

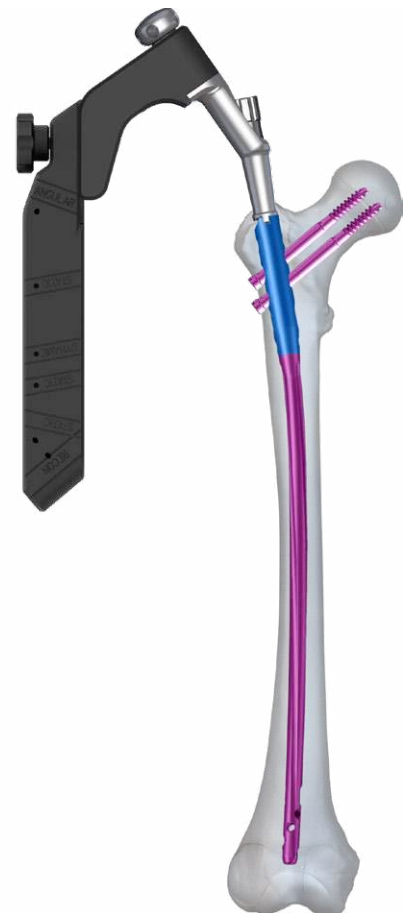
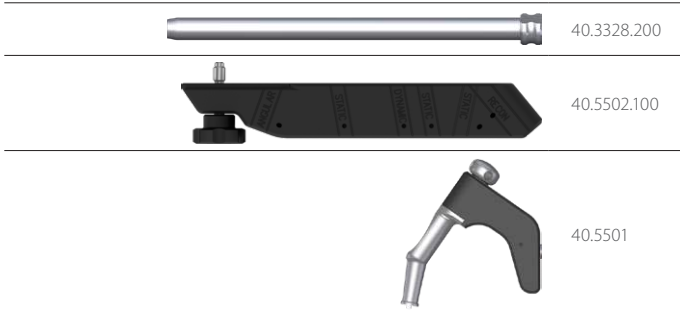

### V.7.1.2. Locking the short nail in distal part

Anatomical femoral nails have a locking hole in distal part that is situated in a fixed distance from nail's beginning, independently from total nail length.



Short nails are universal and can be applied in right and left extremity.

**24** Introduce protective guide 9/7 [40.5510.200] together with trocar 6.5 [40.5534.100] in the most distal angular hole of targeter B [40.5502.100] signed "STATIC". After marking the screw's entry point on the skin, perform incision of soft tissues. Trocar should penetrate to the cortex and mark the entry point for the drill. The protective guide should penetrate together with the trocar until contact with the bone occurs.

Remove the trocar.  
Leave the protective guide inside the targeter B [40.5502.100] hole.



**25** Introduce Drill guide 7/3.5 [40.5511.200] in left protective guide 9/7. Attach drill with scale 3.5/350 [40.5339.002] to the drive and leading it in drill guide, drill a hole in femur through its both cortices and hole in the nail. Scale on the drill shows the length of locking element.



Hole drilling should be performed under the X-Ray image intensifier control.

Detach drive of the drill.  
Remove the drill guide and the drill.

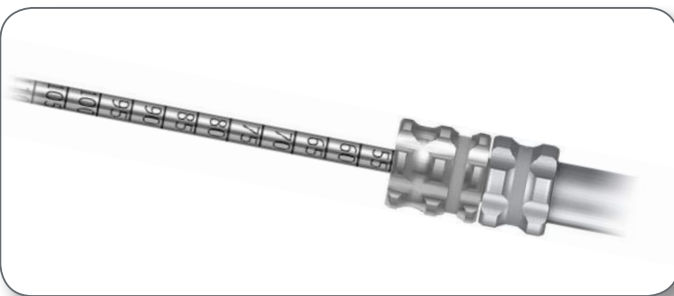
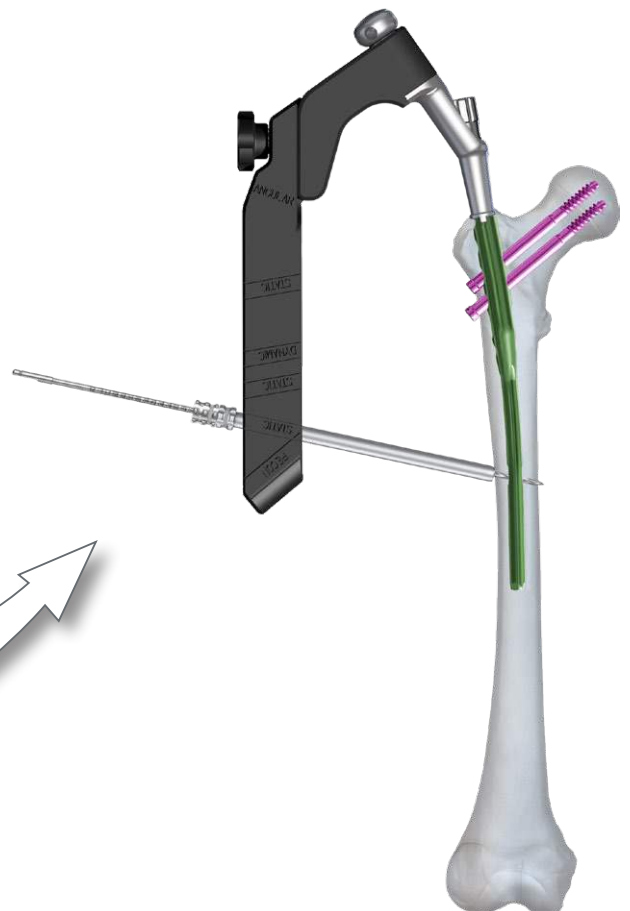
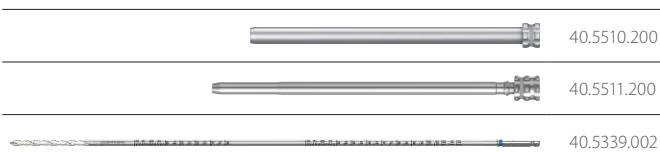



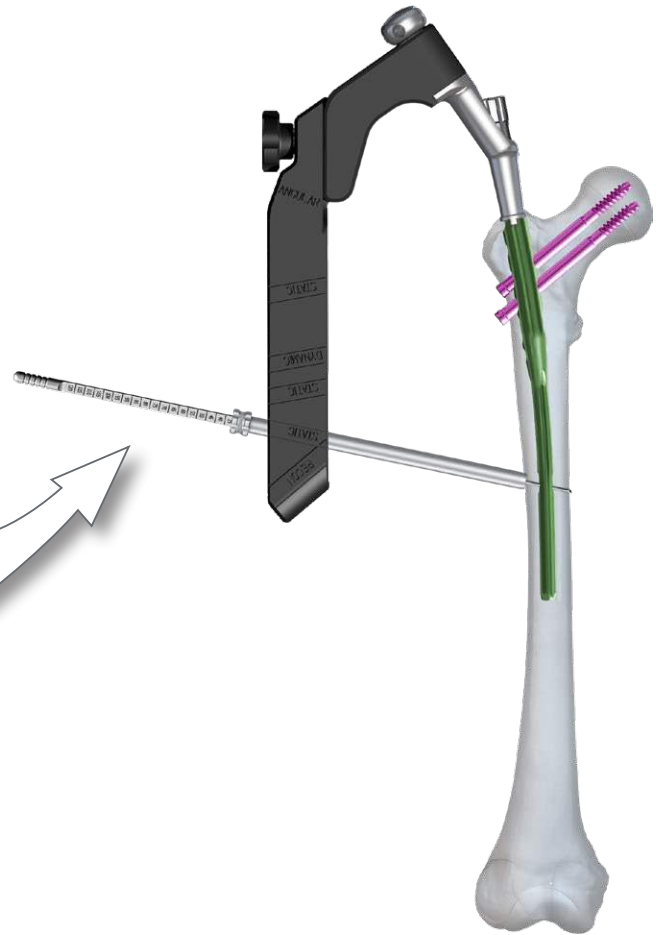
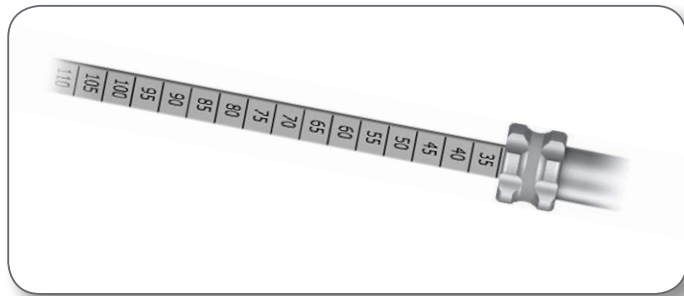
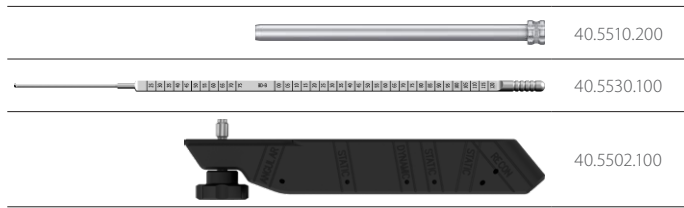

**26** Introduce screw length measure [40.5530.100] through protective guide 9/7 in the hole drilled in the bone, until the hook of measuring tip reaches the far cortex. From the B-D scale of measure, read the locking element length. During measurement the protective guide should be pressed against the cortex.

Remove the screw length measure.  
Leave the protective guide in the targeter hole.



**27** Depending on the diameter of the nail used, locking can be performed with the following screws:

		The diameter of the intramedullary nail			
		Ø9 mm		Ø10 mm and greater	
		Standard locking	Locking with angular stabilization	Standard locking	Locking with angular stabilization
Round hole		<b>CHARFIX2</b> Distal screw 4.0 (turquoise)	<b>CHARFIX2</b> Distal screw 4.5 (brown)	<b>CHARFIX2</b> Distal screw 5.0 (gold)	<b>CHARFIX2</b> Distal screw 5.5 (blue)
Oval-shaped hole		<b>CHARFIX2</b> Distal screw 4.0 (turquoise)		<b>CHARFIX2</b> Distal screw 5.0 (gold)	

28 Introduce the tip of cannulated screwdriver T25 [40.5575.300] in the socket of defined locking screw. Insert the system, through protective guide, into the already prepared hole in femoral shaft until the screw's head reaches the cortex (*groove on the screwdriver's shaft meets with end of the protective guide*).

Remove the screwdriver and the protective guide.

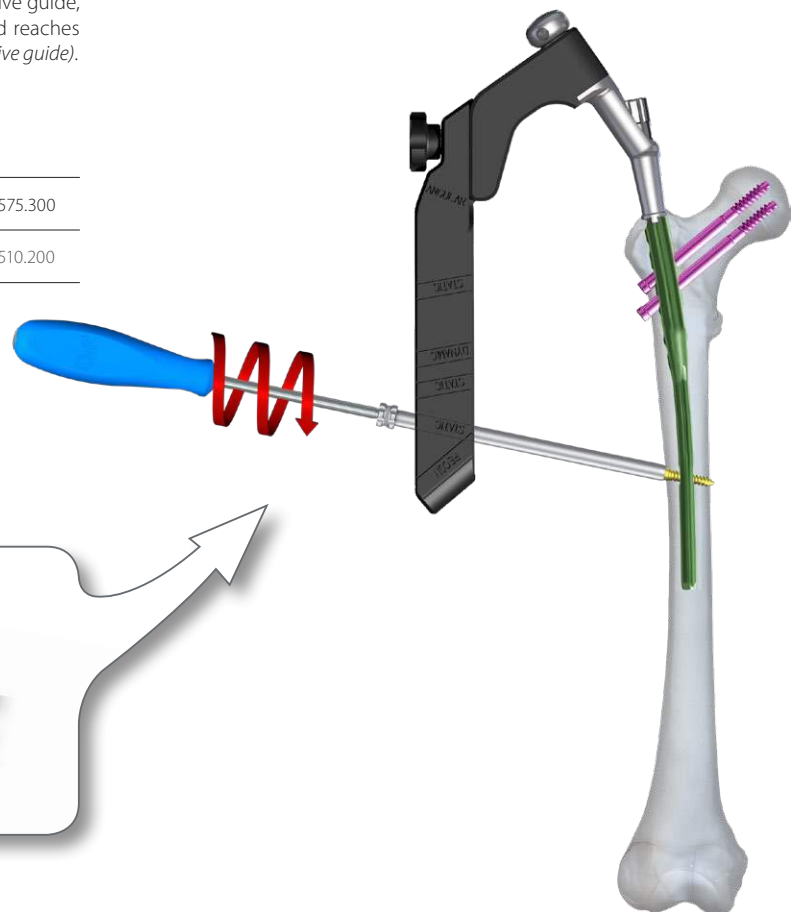
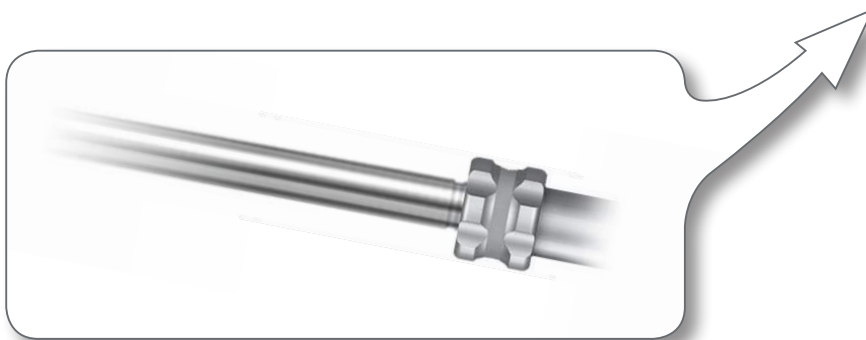
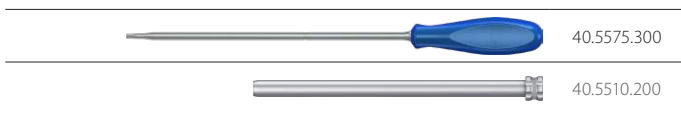

## V.7.1.3. Locking the left/right nail in distal part



When using long left/right nail, remove targeter B [40.5502.100] from targeter arm [40.5501].



40.5502.100



40.5501

29

Couple targeter arm [40.5501] with targeter D [40.5503.300] using screw described in step 7 on page 23.



40.5501



40.5503.300



**NOTE!** Regarding possibility of incorrect positioning of targeter D slider's holes in relation to holes in the nail, the slider has been provided with adjustment screw used for correction of holes configuration.

The alignment of the holes in the nail and the slider should be performed with the adjustment screw of the targeter D slider which allows for the part of the slider to move along the screw until the correct position is reached.



**NOTE!** The position of targeter D [40.5503.300] slider can be verified taking X-Ray image in AP and lateral projections.

If slider positioning requires correction, re-position the slider using the adjustment screw, until correct configuration of holes in the nail and the slider of targeter D is obtained.

Holes in the nail and slider of targeter should overlap and form a circular profile.



**30** Introduce protective guide 9/7 [40.5510.200] together with trocar 6.5 [40.5534.100] in distal hole of targeter D [40.5503.300]. After marking the screw's entry point on the skin, perform incision of soft tissues. Trocar should penetrate to the cortex and mark the entry point for the drill. The protective guide should penetrate together with the trocar until contact with the bone occurs.

Remove the trocar.  
Leave the protective guide inside the targeter D hole.

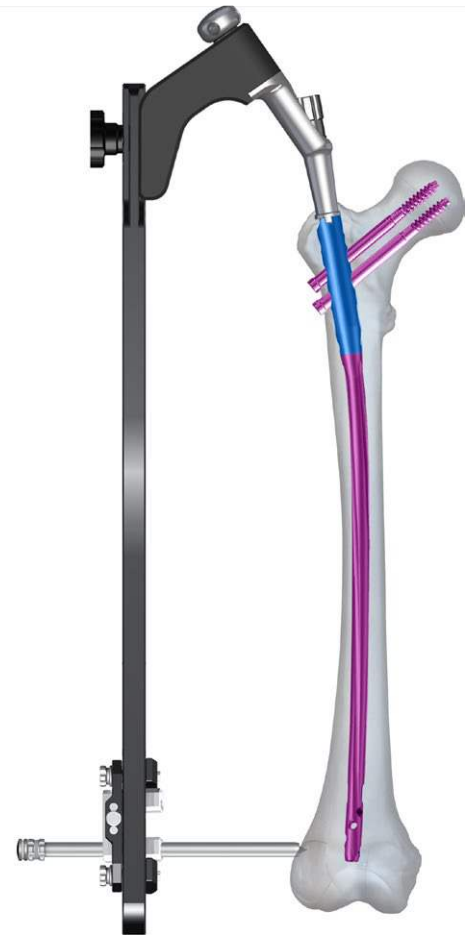
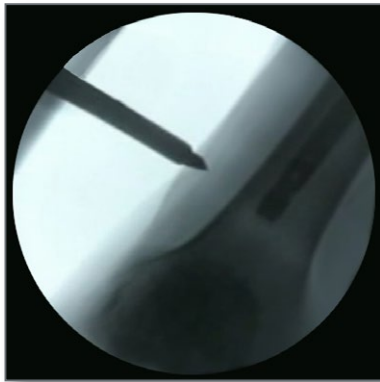
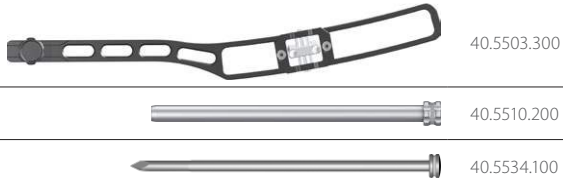

**31** Introduce drill guide 7/3.5 [40.5511.200] in the left protective guide 9/7. Attach drill with scale 3.5/350 [40.5339.002] to the drive and leading it in drill guide, drill a hole in femur through its both cortices and hole in the nail. Scale on the drill shows the length of locking element.



Hole drilling should be performed under the X-Ray image intensifier control.

Detach drive of the drill.  
Remove the drill guide and the drill.

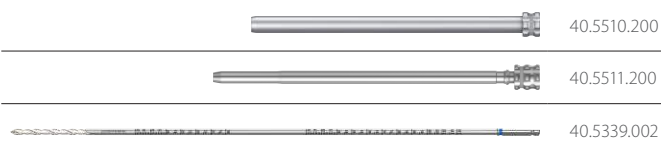

**32** Introduce protective guide 9/7 [40.5510.200] together with trocar 6.5 [40.5534.100] in proximal hole of targeter D slider [40.5503.300]. After marking the screw's entry point on the skin, perform incision of soft tissues. Trocar should penetrate to the cortex and mark the entry point for the drill. The protective guide should penetrate together with the trocar until contact with the bone occurs.

Remove the trocar.  
Leave the protective guide inside the targeter D hole.

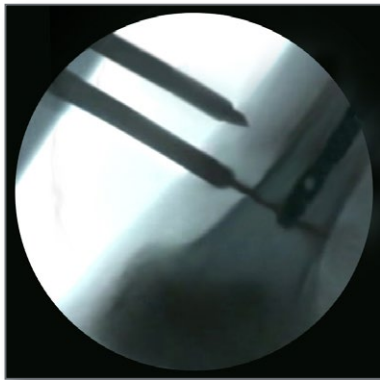
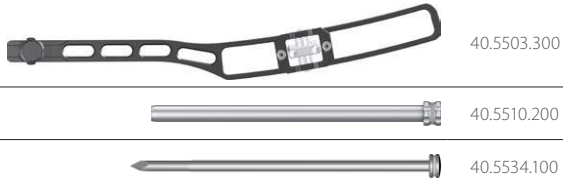

**33** Introduce drill guide 7/3.5 [40.5511.200] in the left protective guide 9/7. Mount drill with scale 3.5/350 [40.5339.002] in drive and then leading the drill in drill guide drill a hole in femur through its both cortices and hole in the nail. Scale on the drill shows the length of locking element.



Drilling hole should be performed under the X-Ray intensifier control.

Detach drive of the drill.  
Remove the drill guide and the drill.

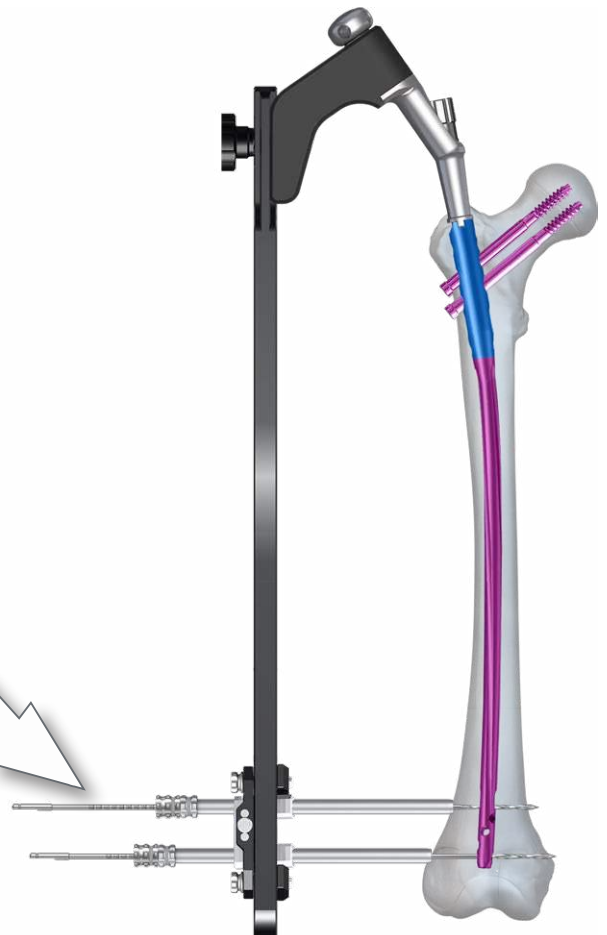
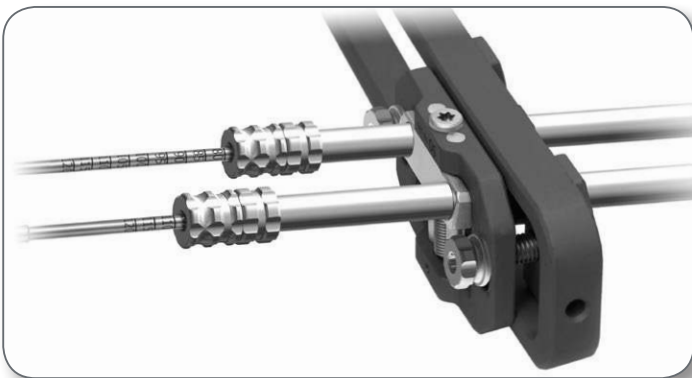
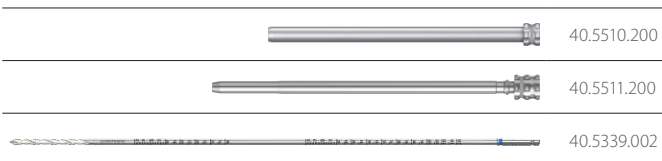

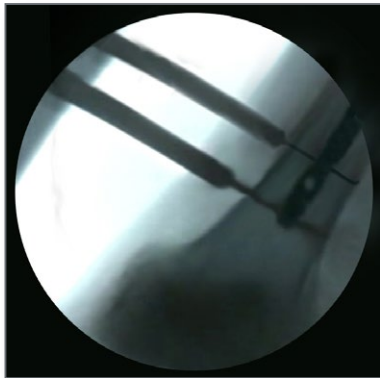
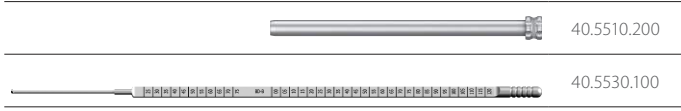

**34** Introduce screw length measure [40.5530.100] through protective guide, in the hole drilled in the bone, until the hook of measuring tip reaches the far cortex. From the B-D scale read the locking element length. During measurement the protection guide should be pressed against the cortex.

Remove the screw length measure.  
Leave the protective guide in the targeter hole.



**35** Depending on the diameter of the nail used, locking can be performed with the following screws:

The diameter of the intramedullary nail					
		Ø9 mm		Ø10 mm and greater	
		Standard locking	Locking with angular stabilization	Standard locking	Locking with angular stabilization
Round hole		<b>CHARFIX2</b> Distal screw 4.0 (turquoise)	<b>CHARFIX2</b> Distal screw 4.5 (brown)	<b>CHARFIX2</b> Distal screw 5.0 (gold)	<b>CHARFIX2</b> Distal screw 5.5 (blue)
Oval-shaped hole		<b>CHARFIX2</b> Distal screw 4.0 (turquoise)		<b>CHARFIX2</b> Distal screw 5.0 (gold)	

**36** Introduce the tip of screwdriver T25 **[40.5575.300]** in the socket of defined locking screw. Insert the system, through protective guide, into the already prepared hole in femoral shaft until the screw's head reaches the cortex (*groove on the screwdriver's shaft meets with end of the protective guide*).

Remove the screwdriver.

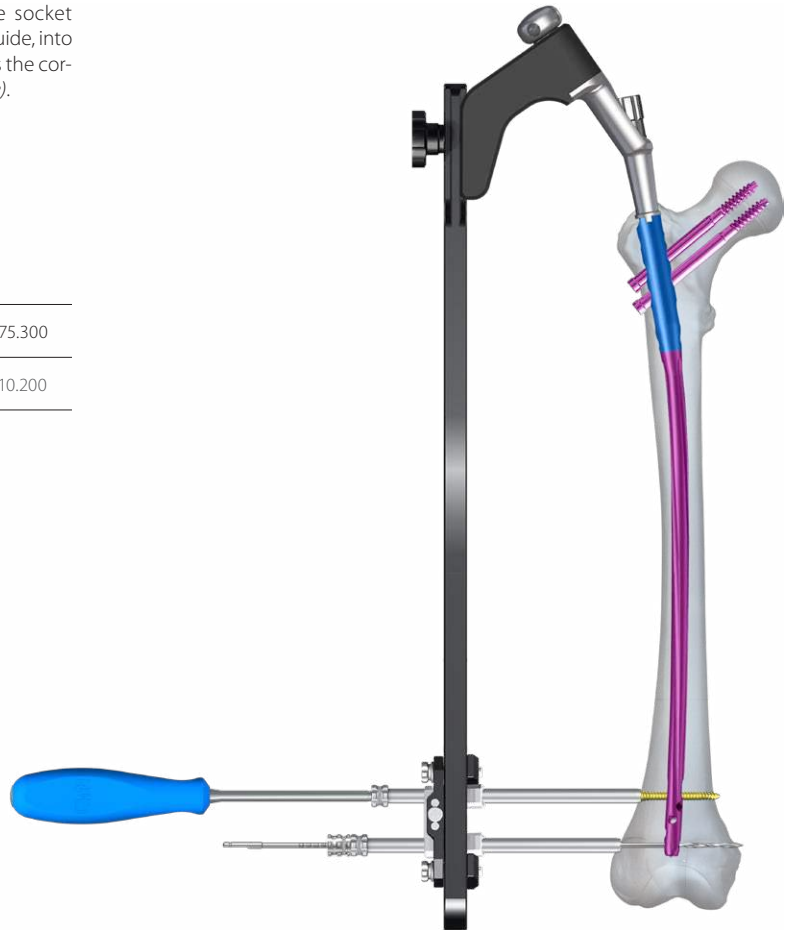
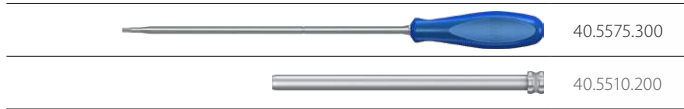

**37** Remove the drill and drill guide from the distal hole of targeter D slider. Leave the protective guide 9/7 in hole of targeter D slider. Introduce screw length measure **[40.5530.100]** through protective guide, in the hole drilled in the bone, until the hook of measuring tip reaches the far cortex. From the B-D measure scale read the locking element length. During measurement the protection guide should be pressed against the cortex.

Remove the screw length measure.  
Leave the protective guide in the targeter hole.

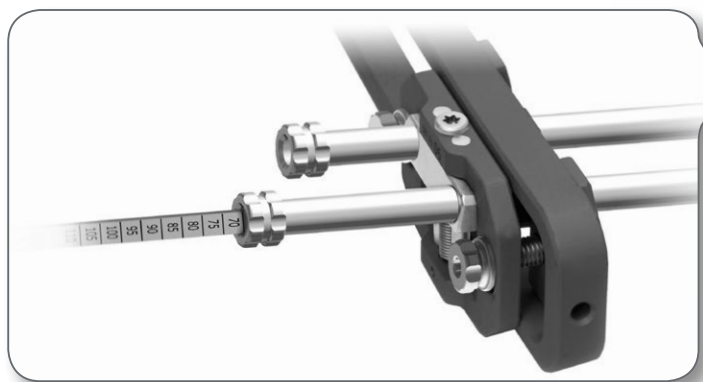
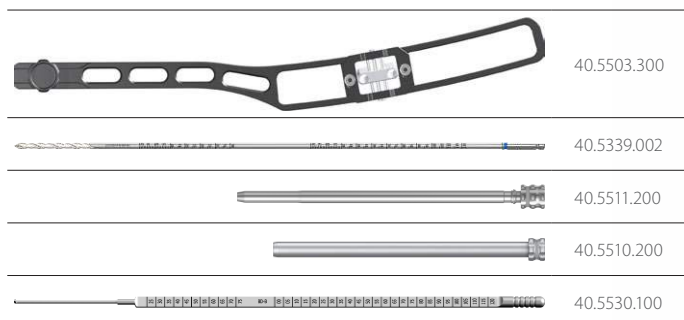

- 38** Introduce the tip of screwdriver T25 [40.5575.300] in the socket of defined locking screw. Insert the system, through protective guide, into the already prepared hole in femoral shaft until the screw's head reaches the cortex (*groove on the screwdriver's shaft meets with end of the protective guide*).

Remove the screwdriver and protective guides.



Correctness of screws insertion in distal part of the nail should be verified by taking a X-Ray image in AP and lateral projection.



40.5575.300



40.5510.200

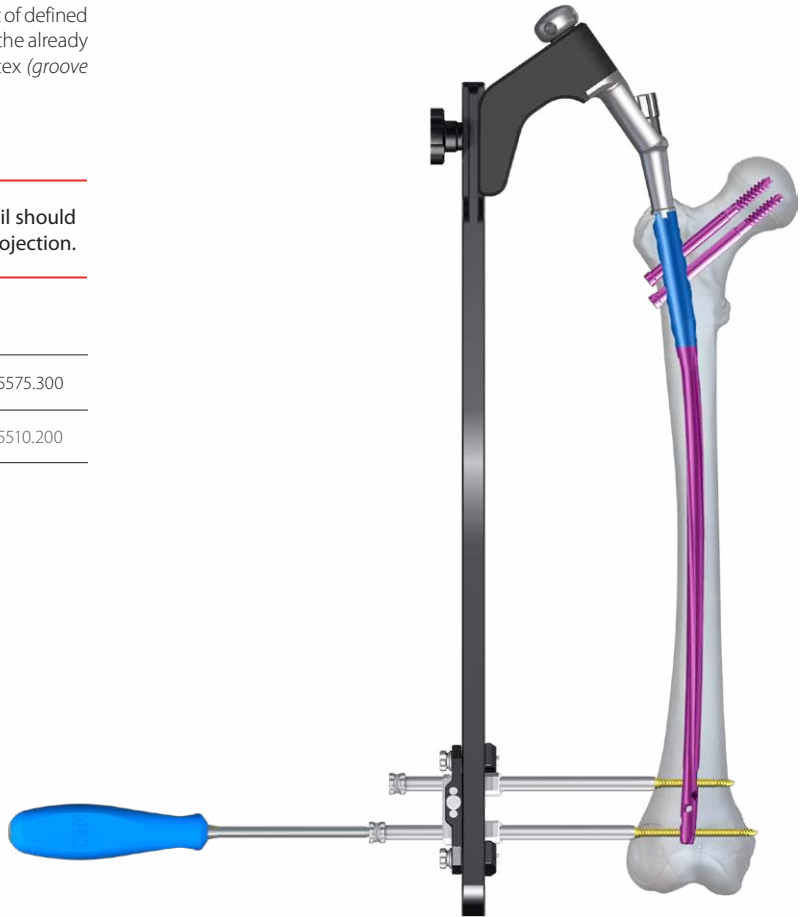
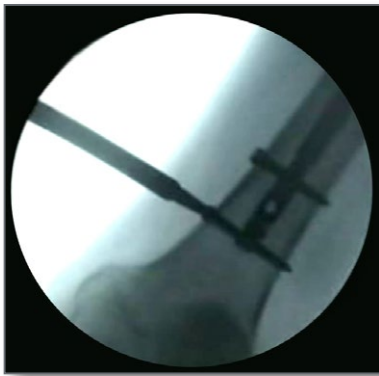



## V.7.1.4. Targeter removal and placing the end cap

**39** Remove the connecting screw M10x1.5 [40.5504] from the proximal end of the intramedullary nail using wrench S10 [40.5526.100] and detach the targeter arm from the nail fixed in the medullary canal.



40.5526.100



40.5504



40.5501

**40** In order to protect the internal thread of the nail against bone tissue overgrowth, insert in the nail's shaft **CHARFIX2** End cap M10x1.5 (implant) using cannulated screwdriver T30 [40.5574.300].



40.5574.300

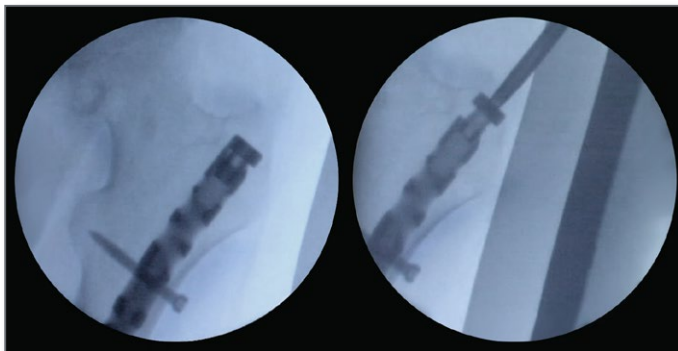

### V.7.1.5. ALTERNATIVE: Locking the nail in distal part using "free-hand" technique



Instant radiographic control is necessary in this method for determination of the drilling points and during the drilling procedure. Angular attachment of the drive is recommended for drilling the holes, so the operator's hands will be outside the direct X-Ray exposure. After marking on the skin the drill entry points for drilling the holes in femoral shaft, perform incision of soft tissues for approximately 1,5 cm.

- 41** Determine under the X-Ray the targeter D position in relation to the hole in the intramedullary nail. The holes in nail and the targeter shall coincide. Edges of the targeter shall penetrate the cortex. Introduce the short trocar 7 [40.1354.100] in the targeter hole, penetrate the cortex with the trocar and mark the entry point for the drill.

Remove the trocar  
Leave the targeter in place.

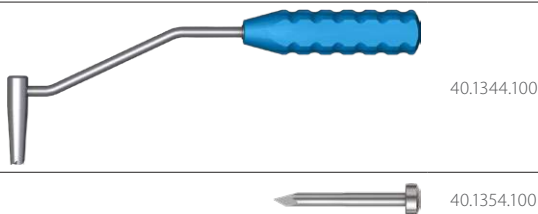

- 42** Introduce the short drill guide 7/3.5 [40.1358.100] in the targeter hole. Drill a hole using drill with scale 3.5/350 [40.5339.002] (guided inside the drill guide) through both cortices and hole in the nail. Scale on the drill shows the length of locking element.

Remove the drill and drill guide.  
Leave the targeter in place.

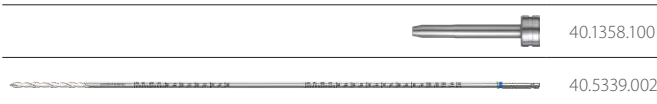





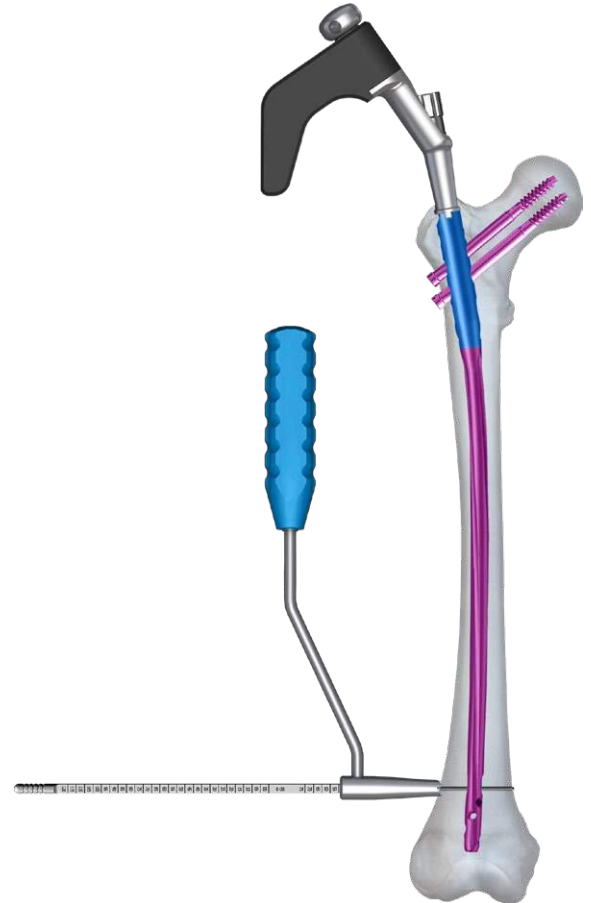
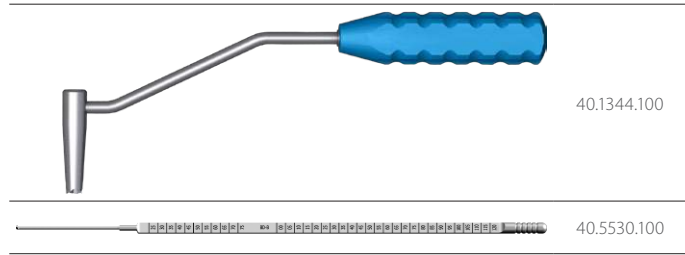



**43** Introduce the screw length measure **[40.5530.100]** through targeter hole, in the hole drilled in the bone, until the hook of measuring tip reaches the far cortex. From the D scale read the locking screw length.

Remove the screw length measure.  
Leave the targeter in place.



**44** Depending on the diameter of the nail used, locking can be performed with the following screws:

The diameter of the intramedullary nail					
		Ø9 mm		Ø10 mm and greater	
		Standard locking	Locking with angular stabilization	Standard locking	Locking with angular stabilization
Round hole		<b>CHARFIX2</b> Distal screw 4.0 (turquoise) 	<b>CHARFIX2</b> Distal screw 4.5 (brown) 	<b>CHARFIX2</b> Distal screw 5.0 (gold) 	<b>CHARFIX2</b> Distal screw 5.5 (blue) 
Oval-shaped hole		<b>CHARFIX2</b> Distal screw 4.0 (turquoise) 		<b>CHARFIX2</b> Distal screw 5.0 (gold) 	

45 Introduce the tip of screwdriver T25 **[40.5575.300]** in the socket of defined locking screw. Insert the system, into the already prepared hole in femoral shaft (*via targeter hole*) until the screw's head reaches the cortex.

Remove the screwdriver and the targeter D.

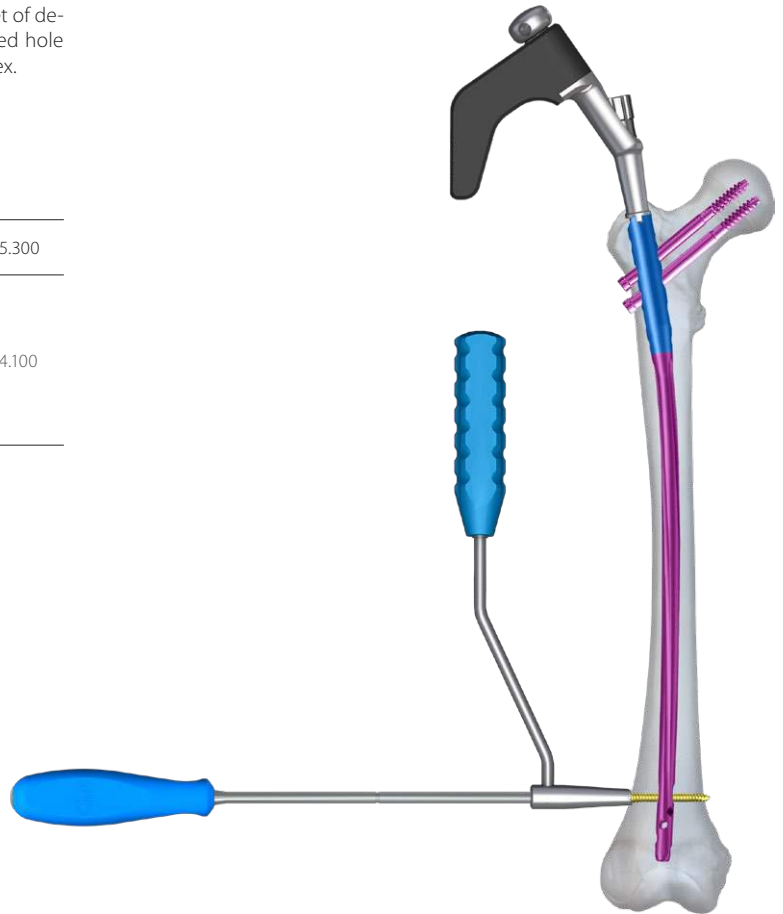
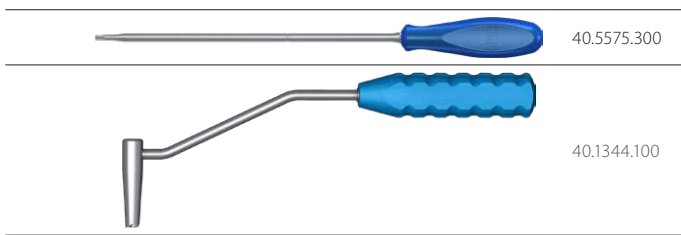

## V.7.2. Compression method

### V.7.2.1. Locking the nail in distal part

- 46** Mount the targeter D **[40.5503.300]** to the targeter arm **[40.5501]** using screw described in step 7 on page 23.



Verify the position of targeter D slider according to step 28 on page 34.



40.5501.000



40.5503.300



Further proceeding according to steps 28÷36.

- 47** After locking the nail in distal part, the reduction of the fracture gap can be performed and further locking in proximal part.

Therefore detach the targeter D **[40.5503.300]** from the targeter arm **[40.5501]** and screw out the mallet screw from the targeter arm. Attach impactor-extractor **[40.5507]**. Slightly backstroke the nail to reduce the fracture gap using Mallet **[40.3667]**.

Detach the impactor-extractor from targeter arm.  
Re-attach the mallet screw in the targeter arm hole.



40.5503.300



40.5501



40.5507



40.3667



## V.7.2.2. Locking the nail in proximal part



**IMPORTANT!** In compression method, for locking the anatomical femoral nail, hole in targeter B [40.5502.100] signed "DYNAMIC" is used.

## V.7.2.2a. OPTION I: Intra-operative compression of fragments using compression screw [40.5517] (instrument)



40.5517



**48** Attach targeter B [40.5502.100] to the targeter arm [40.5501]. Introduce protective guide 9/7 [40.5510.200] together with trocar 6.5 [40.5534.100] in the hole of targeter B [40.5502.100] signed "DYNAMIC". After marking the screw's entry point on the skin, perform 1,5 cm long incision of soft tissues.

Trocar should penetrate to the cortex and mark the entry point for the drill. The protective guide should penetrate together with the trocar until contact with the bone occurs.

Remove the trocar.

Leave the protective guide inside the targeter B hole.



40.5502.100



40.5501



40.5510.200



40.5534.100

**49** Introduce drill guide 7/3.5 [40.5511.200] in the left protective guide. Attach drill with scale 3.5/350 [40.5339.002] to the drive and leading it in drill guide, drill a hole in femur through its both cortices and hole in the nail. Scale on the drill shows the length of locking element.

Remove the drill and drill guide.

Leave the protective guide in the targeter hole.



40.5511.200



40.5339.002



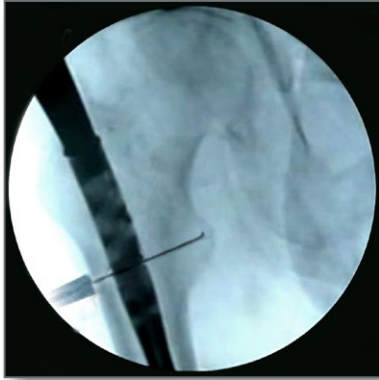
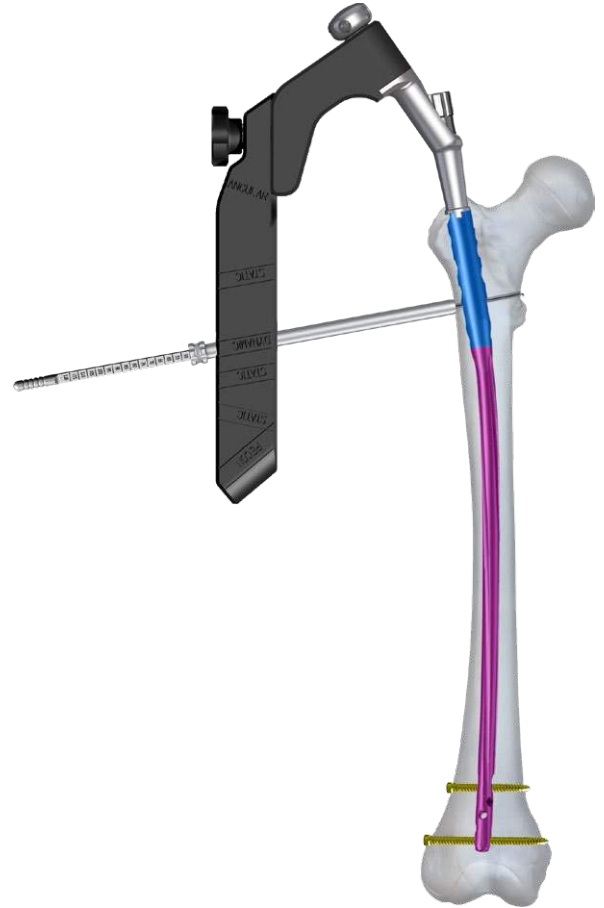
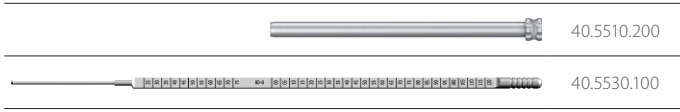

**50** Introduce the screw length measure **[40.5530.100]** through protective guide 9/7 **[40.5510.200]**, in the hole drilled in the bone, until the hook of measuring tip reaches the far cortex. From the B-D scale read the locking screw length. During measurement the protective guide should be pressed against the cortex.

Remove the screw length measure.  
Leave the protective guide in the targeter hole.



**51** Depending on the diameter of the nail used, locking can be performed with the following screws:

		The diameter of the intramedullary nail			
		Ø9 mm		Ø10 mm and greater	
		Standard locking	Locking with angular stabilization	Standard locking	Locking with angular stabilization
Round hole		<b>CHARFIX2</b> Distal screw 4.0 (turquoise)	<b>CHARFIX2</b> Distal screw 4.5 (brown)	<b>CHARFIX2</b> Distal screw 5.0 (gold)	<b>CHARFIX2</b> Distal screw 5.5 (blue)
Oval-shaped hole		<b>CHARFIX2</b> Distal screw 4.0 (turquoise)		<b>CHARFIX2</b> Distal screw 5.0 (gold)	

- 52** Introduce the tip of screwdriver T25 [40.5575.300] in the socket of defined locking screw. Insert the system, through protective guide, into the already prepared hole in femoral shaft until the screw's head reaches the cortex (groove on the screwdriver's shaft meets with end of the protective guide).

Remove the screwdriver and the protective guide.



40.5575.300

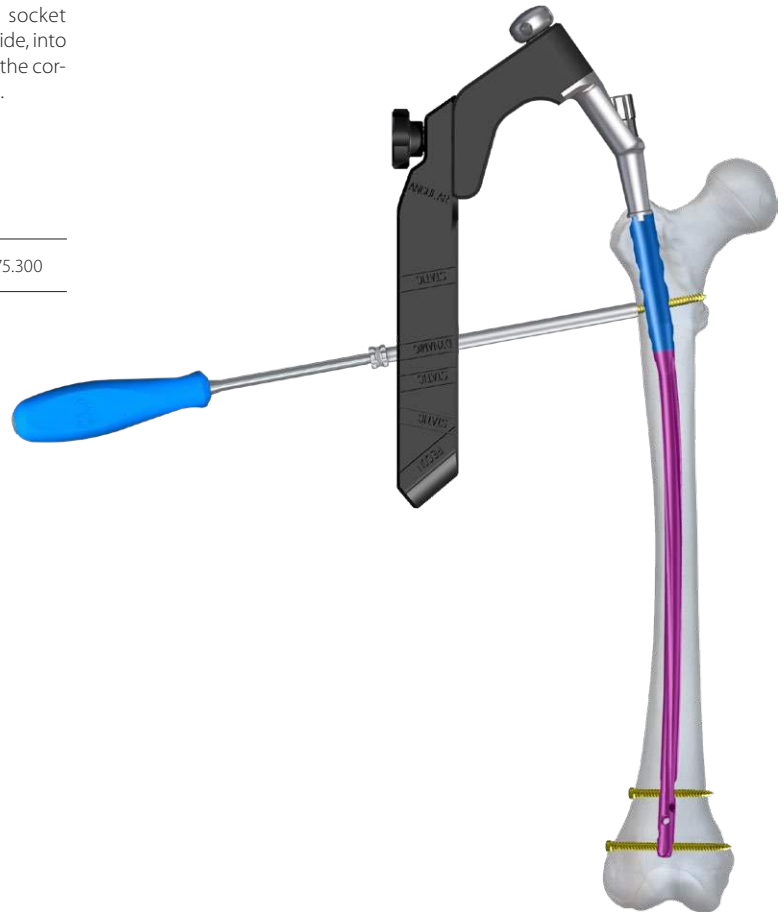

- 53** In order to perform intraoperative compression, insert the compression screw [40.5517] in connecting screw M10x1.5 [40.5504], that joins the intramedullary nail with targeter arm [40.5501], using cannulated screwdriver T30 [40.5574.300]. When face of the compression screw meets the shaft of the locking screw, a perceptible resistance occurs. From this moment on, a further compression screw insertion will result in bone fragments compression.



Perform the insertion under the X-Ray image intensifier control, monitoring the inter-fragmental gap.



40.5574.300



40.5517



40.5504



40.5501

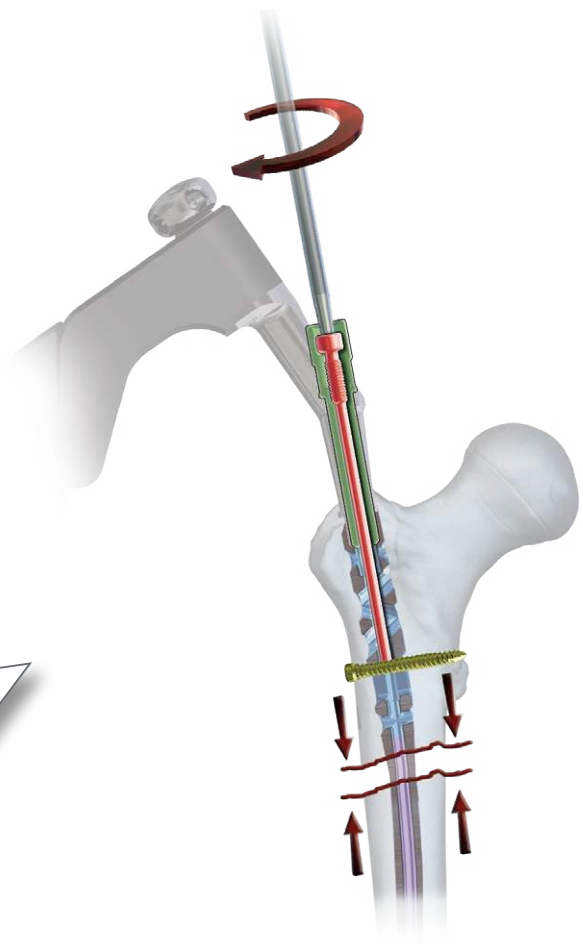



**54** In order to keep the fragments compression, static locking of the nail should be performed. For this purpose, introduce protective guide 9/7 [40.5510.200] together with trocar 6.5 [40.5534.100] in the distal hole of targeter B [40.5502.100] signed "STATIC".

After marking the screw's entry point on the skin, perform 1,5 cm long incision of soft tissues.

Trocar should penetrate to the cortex and mark the entry point for the drill.

The protective guide should penetrate together with the trocar so as to place its end as close to the bone as possible.

Remove the trocar.

Leave the protective guide inside the targeter hole.

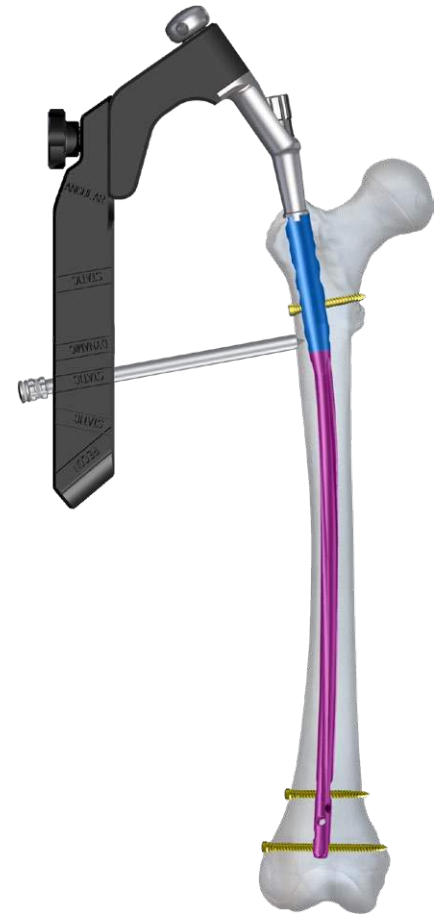
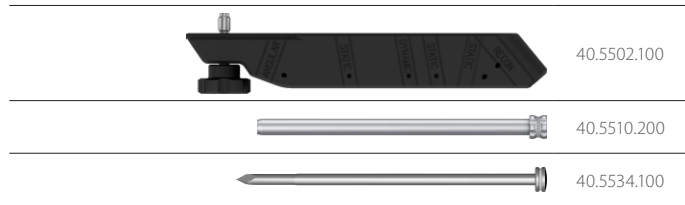

**55** Introduce drill guide 7/3.5 [40.5511.200] in the left protective guide 9/7. Attach drill with scale 3.5/350 [40.5339.002] to the drive and leading it in drill guide, drill a hole in femur through its both cortices and hole in the nail. Scale on the drill shows the length of locking element.

Remove the drill and drill guide.

Leave the protective guide in the targeter hole.

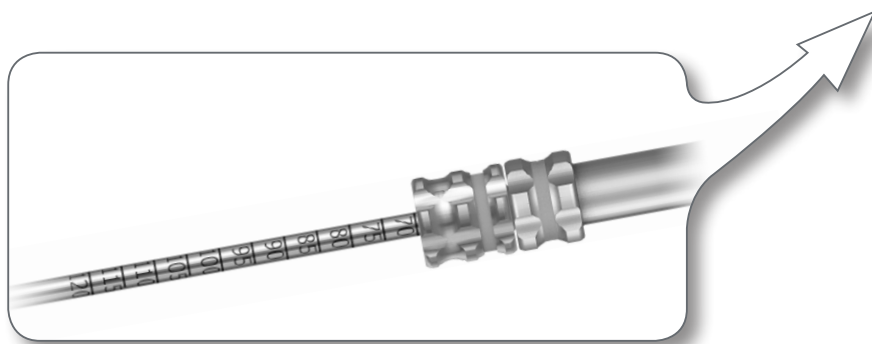
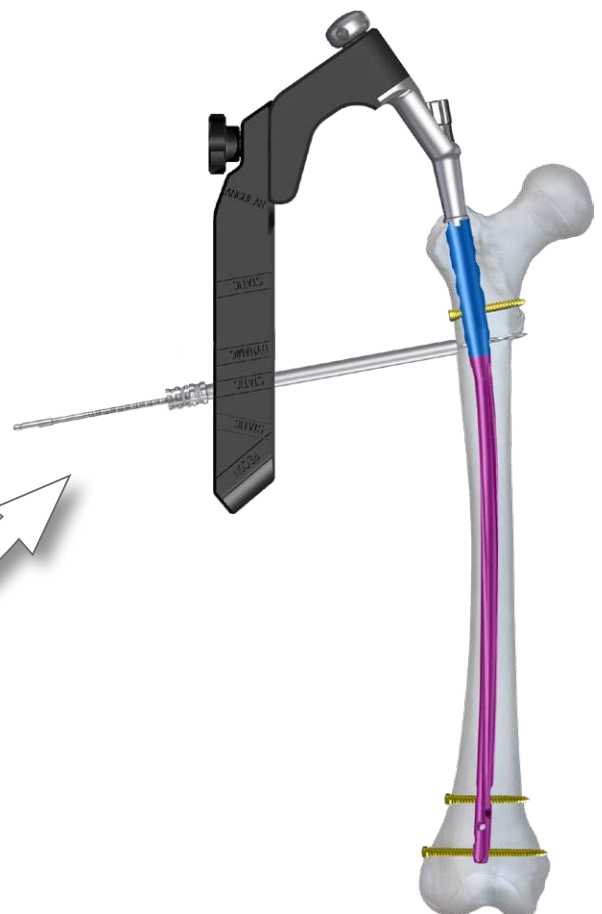
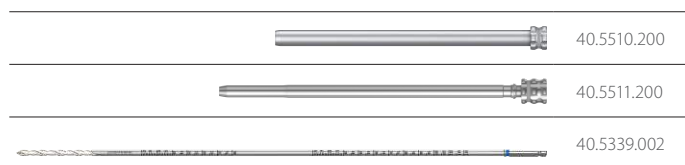

- 56** Introduce the screw length measure **[40.5530.100]** through the protective guide, in the hole drilled in the bone, until the hook of measuring tip grasps the far cortex. From the B-D scale read the locking screw length. During measurement the protection guide should be pressed against the cortex.

Remove the screw length measure.  
Leave the protective guide in the targeter hole.

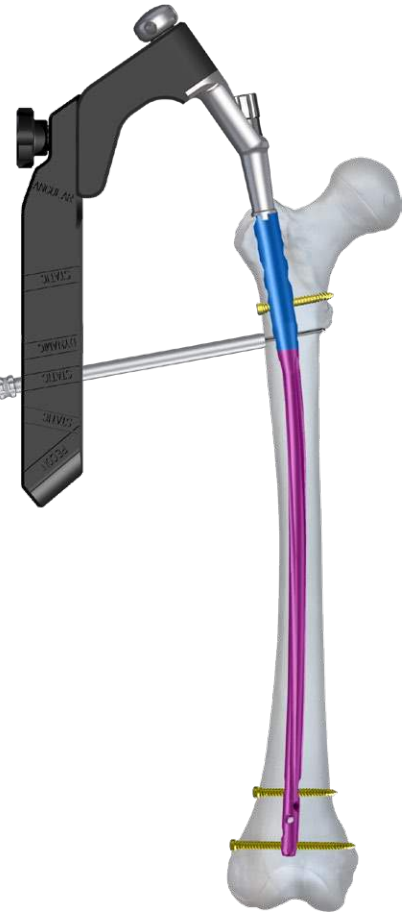
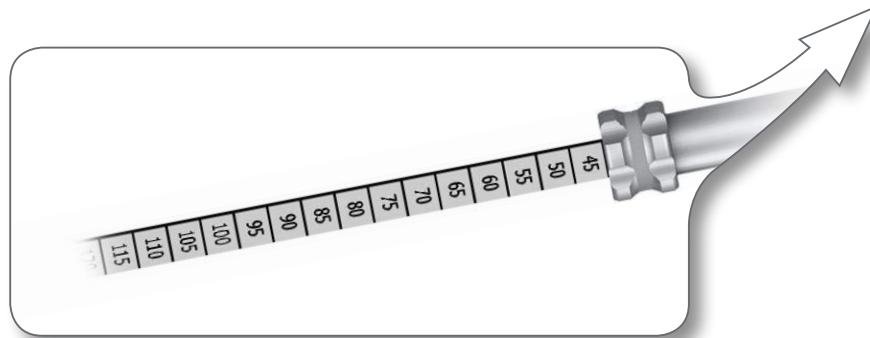
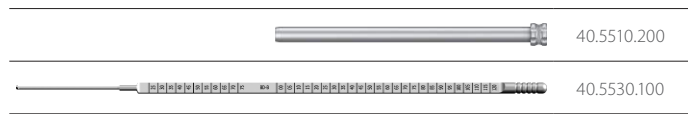

- 57** Introduce the tip of screwdriver T25 **[40.5575.300]** in the socket of defined locking screw. Insert the system, through protective guide, into the already prepared hole in femoral shaft until the screw's head reaches the cortex (groove on the screwdriver's shaft meets with end of the protective guide).

Remove the screwdriver and the protective guide.

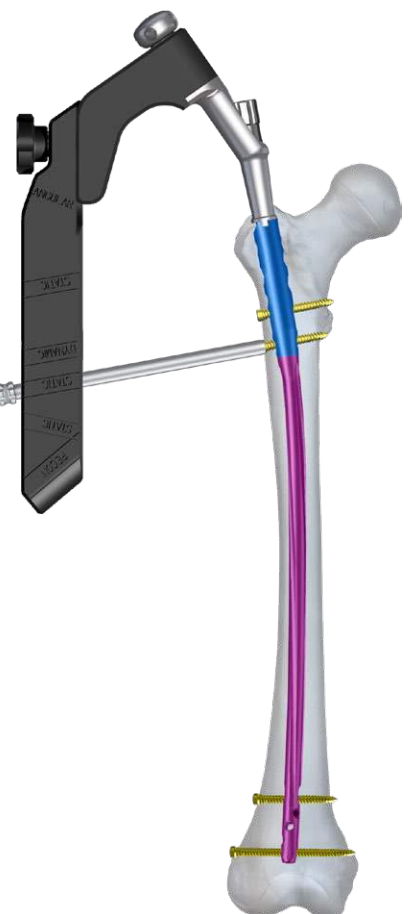
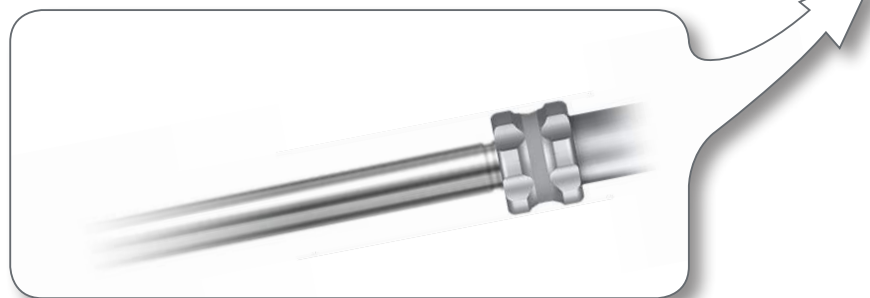

- 58 Remove compression screw **[40.5517]** from connecting screw M10x1,5 L=53 **[40.5504]** using cannulated screwdriver T30 **[40.5574.300]**.

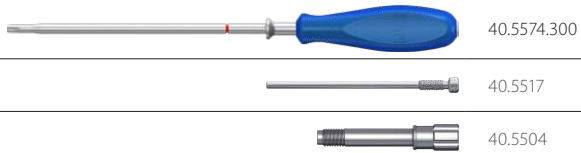

**ATTENTION!** Further proceeding according to steps described in section IV.7.3.3.



### V.7.2.2b. OPTION II: Compression of fragments using CHARFIX2 Compression screw M10x1,5 [3.5162.000] (implant)

Option of compressive locking in proximal part with use of **CHARFIX2** Compression screw M10x1.5 (implant delivered separately) should be performed according to steps 45÷48, then according to procedure described in section IV.7.2.3.



3.5162

### V.7.2.3. Targeter removal and placing the compression screw

- 59** Remove targeter B [40.5502.100] from targeter arm [40.5501].  
Remove connecting screw M10x1.5 [40.5504] from the proximal end of the intramedullary nail using wrench S10 [40.5526.100] and detach the targeter arm from the nail fixed in the medullary canal.



40.5502.100



40.5501



40.5526.100



40.5504

- 60** Drive in **CHARFIX2** Compression screw M10x1.5 [3.5162] in threaded hole of nail shaft using cannulated screwdriver T30 [40.5574.300].



Surgeon decides about the compression rate.



40.5574.300



3.5162

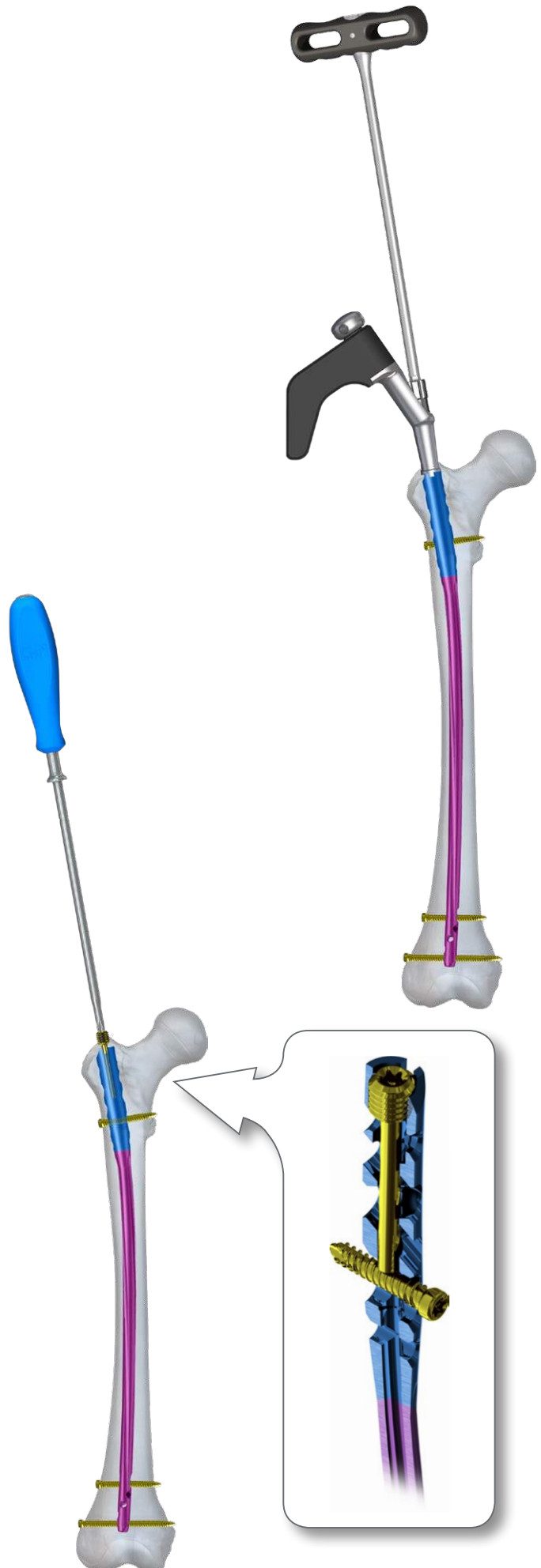

### V.7.3. Dynamic method

#### V.7.3.1. Locking the nail in distal part

Locking the nail in distal part in dynamic method perform according to steps 28÷36.



**61** After locking the nail in distal part the reduction of the fracture gap can be performed and further locking in proximal part.

Remove targeter D **[40.5503.300]** from the targeter arm **[40.5501]** and screw out the mallet screw from the targeter arm **[40.5501]**. Attach impactor-extractor **[40.5507]**. Slightly backstroke the nail to reduce the fracture gap using mallet **[40.3667]**.

Detach the impactor-extractor from targeter arm.  
Re-attach mallet screw to the targeter arm.



#### V.7.3.2. Locking the nail in proximal part

**62** Locking the nail in proximal part in dynamic method perform according to steps 45÷48.

## V.7.3.3. Targeter removal and placing the end cap

- 63** Remove targeter B [40.5502.100] from targeter arm [40.5501].  
Remove connecting screw M10x1.5 [40.5504] from the proximal end of the intramedullary nail using wrench S10 [40.5526.100] and detach the targeter arm from the nail fixed in the medullary canal.



- 64** In order to protect the connecting thread of the nail against bone tissue overgrowth, insert in the nail's threaded hole **CHARFIX2** End cap M10x1.5 (implant delivered separately) [3.5161.7xx] using cannulated screwdriver T30 [40.5574.300].



## V.7.4. Static method

### V.7.4.1. Locking the nail in distal part

Locking the nail in distal part in static method perform according to steps 28÷36.

### V.7.4.2. Locking the nail in proximal part

#### V.7.4.2a. **OPTION I:** Locking the nail with reconstruction screw

Locking the anatomical femoral nail with reconstruction screw in static method allows to reduce operative wound, because this solution enables to perform one incision for nail introduction into the medullary canal and for locking in proximal part. Besides, angular screw position ensures stabile locking, therefore, application of additional locking screws is not necessary.

65

Attach targeter B [40.5502.100] to the targeter arm [40.5501]. Introduce protective guide 11/9 [40.3328.200] together with trocar 6.5 [40.3327.100] in hole of targeter B [40.5502.100] signed "ANGULAR". After marking the screw's entry point on the skin, perform incision of soft tissues. Trocar should penetrate to the cortex and mark the entry point for the drill. The protective guide should penetrate together with the trocar so as to place its end as near to the bone as possible.

Remove the trocar.

Leave the protective guide inside the targeter hole.

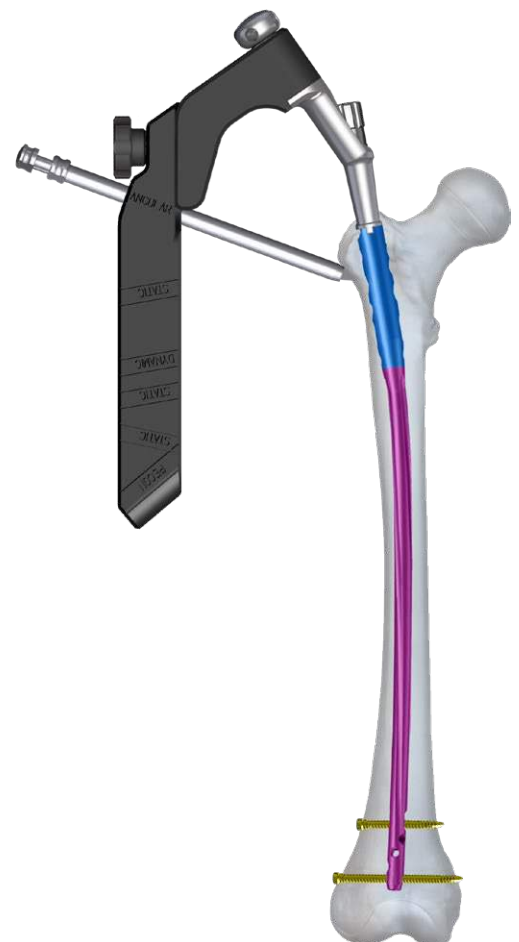
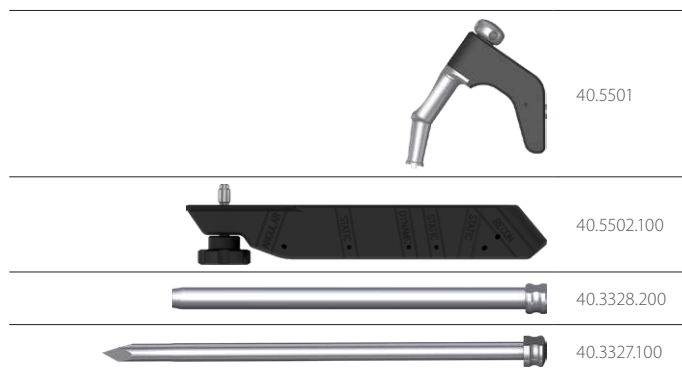



- 66** Introduce guide 9/2.8 [40.5508.200] in protective guide [40.3328.200].  
Mount the guide rod 2.8/385 [40.5531] in the drive.  
Leading in guide 9/2.8, introduce the guide rod in greater trochanter, until the rod exits the far cortex (*lesser trochanter area*).

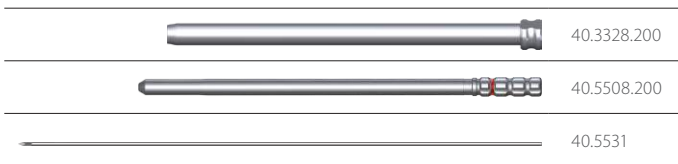

**NOTE!** Described operations should be performed under the X-Ray image intensifier control in AP and lateral projection.



Repeat the operation in the case of incorrect guide rod introduction.

Leave the guide rod 2.8/385, guide 9/2.8 and protective guide 11/9 in the target hole.



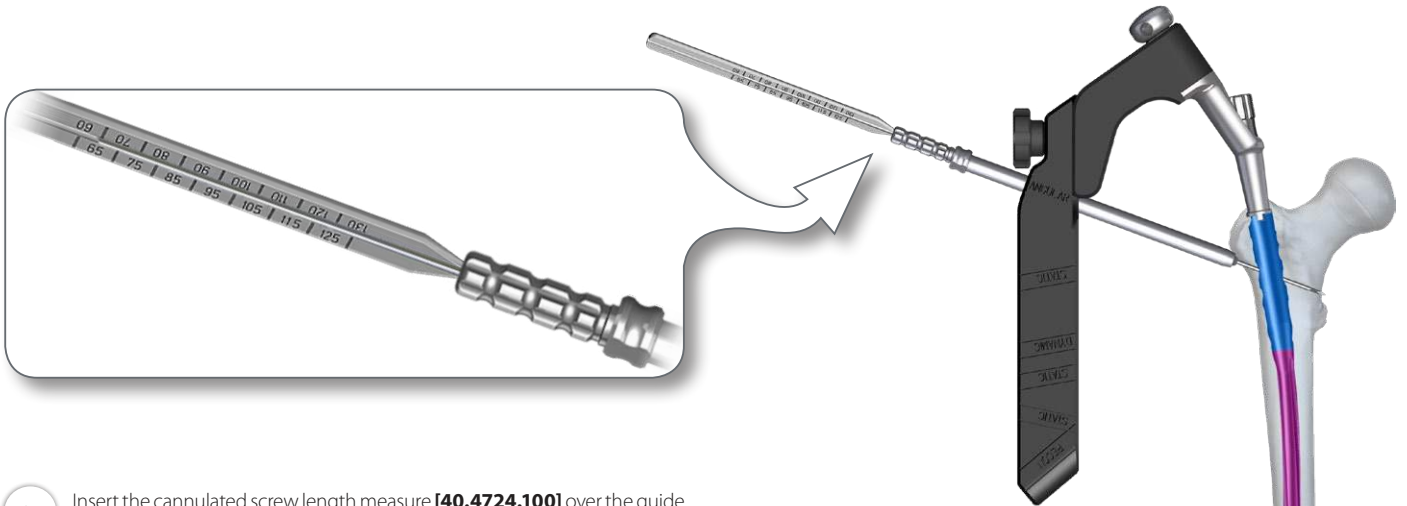

**67** Insert the cannulated screw length measure **[40.4724.100]** over the guide rod placed in greater trochanter of femur, so that its tapered end leans against the protective guide. Read the length of reconstruction cannulated screw from scale that is pointed by end of the guide rod. During the measurement the protective guide 9,0/2,8 **[40.5508.200]** should be in contact with the cortex bone.

Remove the cannulated screw length measure **[40.4724.100]** and protective guide 9,0/2,8 **[40.5508.200]**.  
Leave the guide rod.

	40.5531
	40.4724.100
	40.5508.200

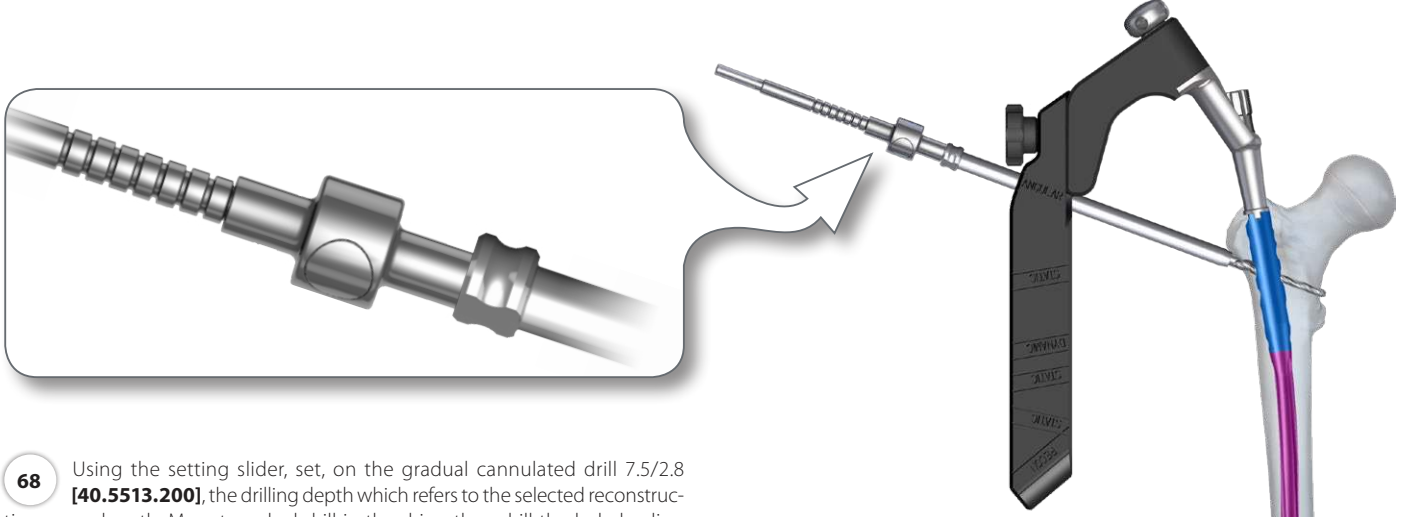

**68** Using the setting slider, set, on the gradual cannulated drill 7.5/2.8 **[40.5513.200]**, the drilling depth which refers to the selected reconstruction screw length. Mount gradual drill in the drive, then drill the hole leading the drill on guide rod inside the protective guide **[40.3328.200]** until the set on the drill slider leans against protective guide **[40.3328.200]**. Control drilling under image intensifier.

Perform the insertion under the X-Ray image intensifier control, monitoring the inter-fragmental gap.

Leave protective guide in targeter hole.

	40.5513.200
	40.5531
	40.3328.200

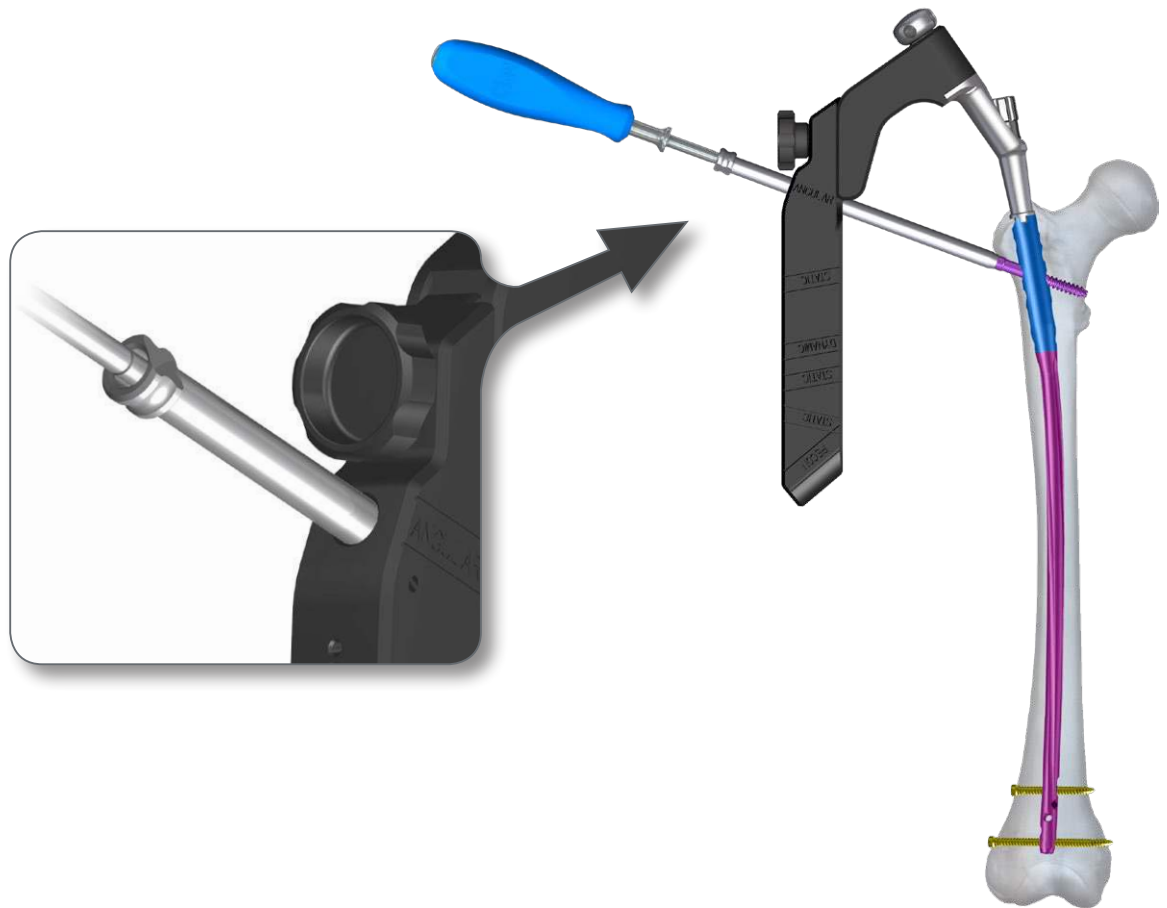

**69** Mount reconstruction screw with previously defined length (set on the cannulated drill using the setting slider or determined with cannulated screw length measure) on the tip of cannulated screwdriver T30 [40.5574.300]. Introduce the system in protective guide [40.3328.200] and drive into previously prepared hole until the screws head reaches the cortex bone layer (circumferential groove on the screwdriver shaft will align with the front of protective guide).

Remove the cannulated screwdriver and protective guide.

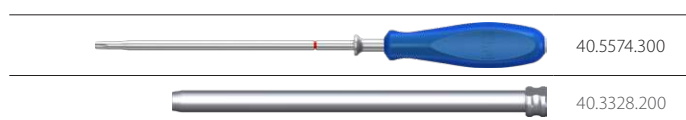

V.7.4.2b. **OPTION II: Locking the nail with locking screws**

Construction of anatomical femoral nail and instrument set provides two holes in proximal part for static locking with use of locking screws. Holes in targeter B **[40.5502.100]** are marked **STATIC**.

- 70** Introduce the protective guide **[40.5510.200]** together with trocar **[40.5534.100]** in distal static (*STATIC*) hole of targeter B. Perform 1,5cm long incision of soft tissues in a place defined as entry point for locking screw. Reach the cortex with the trocar and mark the drill entry point. The protective guide should penetrate together with trocar, in order to be placed as close to the bone as possible.

Remove the trocar.  
Leave the protective guide in targeter hole.

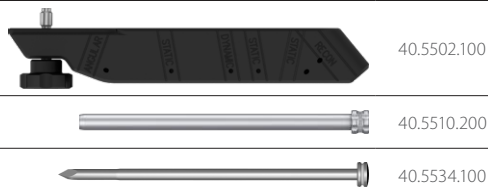

- 71** Introduce drill guide 7/3.5 **[40.5511.200]** into left protective guide. Mount drill with scale 3.5/350 **[40.5339.002]** in the drive, then leading the drill through both guides drill the hole in femur, through both cortices and hole in the nail. Scale on the drill indicates length of locking element.

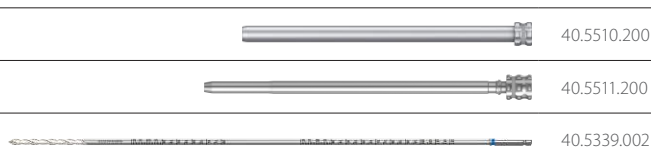

Remove the drill guide and drill.  
Leave the protective guide.

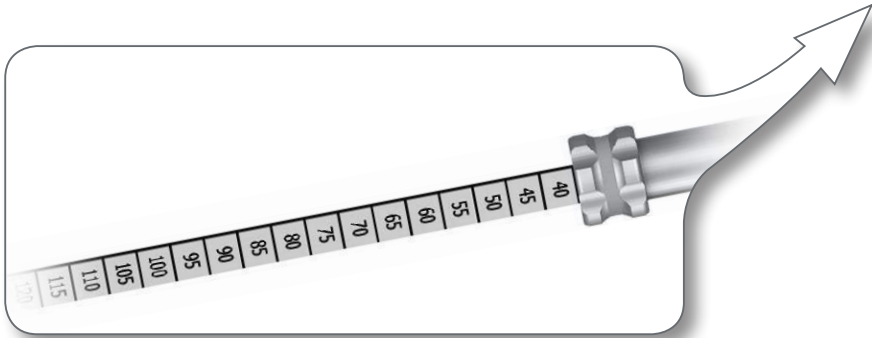
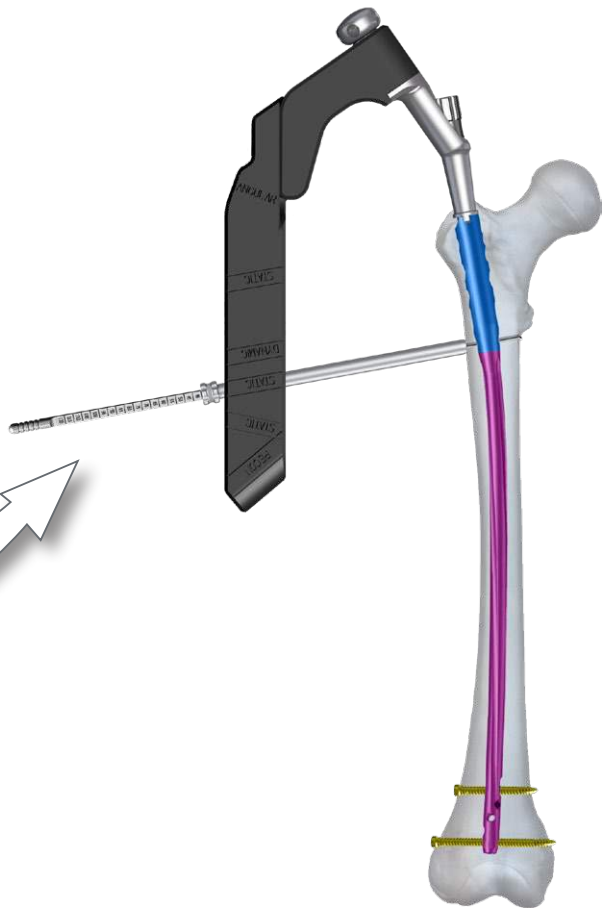
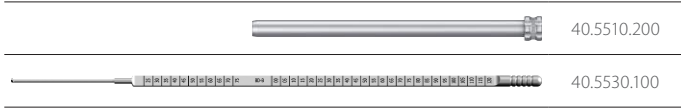

**72** Introduce the screw length measure **[40.5530.100]** through the protective guide **[40.5510.200]** into hole drilled in the bone, until the end of measuring tip reaches the end of the hole. From the B-D scale of the screw length measure read the locking screw length. During the measurement the tip of the protective guide should rest on the cortex bone. Remove the screw length measure. Leave the protective guide in hole of the targeter.



**73** Depending on the diameter of the nail used, locking can be performed with the following screws:

		The diameter of the intramedullary nail			
		Ø9 mm		Ø10 mm and greater	
		Standard locking	Locking with angular stabilization	Standard locking	Locking with angular stabilization
Round hole		<b>CHARFIX2</b> Distal screw 4.0 (turquoise)	<b>CHARFIX2</b> Distal screw 4.5 (brown)	<b>CHARFIX2</b> Distal screw 5.0 (gold)	<b>CHARFIX2</b> Distal screw 5.5 (blue)
Oval-shaped hole		<b>CHARFIX2</b> Distal screw 4.0 (turquoise)		<b>CHARFIX2</b> Distal screw 5.0 (gold)	

**74** Insert the tip of the screwdriver **[40.5575.300]** into the socket of defined locking screw. Next, insert such coupled system into protective guide. Drive the locking screw into previously drilled hole in femoral shaft, until its head reaches the cortical bone layer (*circumferential groove on the screwdriver shaft will align with the front of protective guide*).

Remove the screwdriver and protective guide.

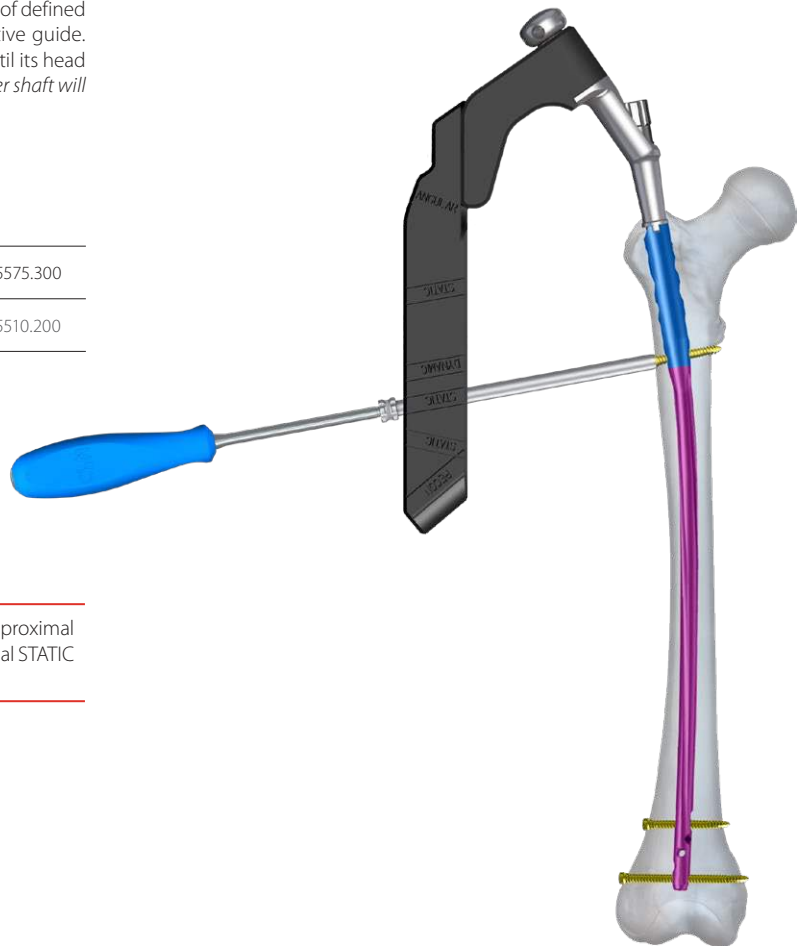
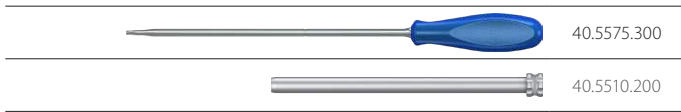

**ATTENTION!** If the surgeon decides to lock the nail in the proximal part using two screws - to lock using second screw (proximal STATIC hole) follow steps 66-69.

### V.7.4.2c. OPTION III: Postoperative dynamization of static osteosynthesis

Construction of the anatomical femoral nail allows dynamization of static osteosynthesis, owing to application of compression hole in distal or proximal part. Option of locking with secondary dynamization can be used in the case of transverse, rotationally stable fractures.

- 75** For the dynamization to occur, at least one compression hole for locking the nail in static method needs to be used. Dynamization of static osteosynthesis consists in driving all screws out of static holes in one end of the nail, and leaving the screw in compression hole.
- Dynamization of static osteosynthesis is used in postoperative period, so possibility of its application should be considered.

- 76** Perform the 1,5cm long incision over the head of screw inserted in the locking hole. Introduce the tip of screwdriver T25 into the screw's socket, through the surgical wound. Drive the screw out of nail's locking hole, leave the screw placed in the compression hole.



## V.7.4.3. Targeter detachment and end cap placement

- 77** Remove targeter B [40.5502.100] from targeter arm [40.5501].  
Remove connecting screw M10x1.5 [40.5504] from the proximal end of the nail using wrench S10 [40.5526.100] and detach the targeter of the nail locked in the medullary canal.



- 78** To secure the connecting thread of the nail against bone overgrowth, insert **CHARFIX2** End cap (implant delivered separately) [3.5161.7xx] guided via guide rod 2.8/385 [40.5531] into threaded hole in nail's shank using cannulated screwdriver T30 [40.5574.300].



## V.8. NAIL REMOVAL

**79** Remove the end cap or compression screw from intramedullary nail using cannulated screwdriver T30 [40.5574.300]. Insert the connector M10x1,5/M12 [40.5512] into the threaded hole in proximal end of the intramedullary nail. Then, remove all locking screws using screwdriver T25 [40.5575.300], while reconstruction screws using cannulated screwdriver T30 [40.5574.300]. Attach the impactor-extractor [40.5507] to the connector. Remove the nail of the medullary canal using mallet.

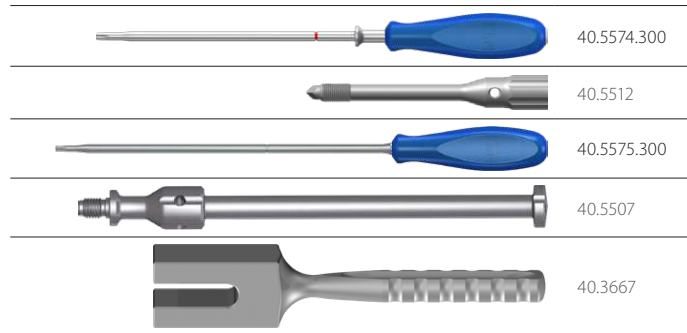





**ChM sp. z o.o.**

Lewickie 3b  
16-061 Juchnowiec Kościelny  
Poland

tel. +48 85 86 86 100

fax +48 85 86 86 101

chm@chm.eu

www.chm.eu



CE 0197