

CHM[®]

CHARFIX *system 2*

INTRAMEDULLARY OSTEOSYNTHESIS OF FEMUR WITH CONDYLAR NAIL

- *IMPLANTS*
- *INSTRUMENT SET 40.5860.500*
- *SURGICAL TECHNIQUE*

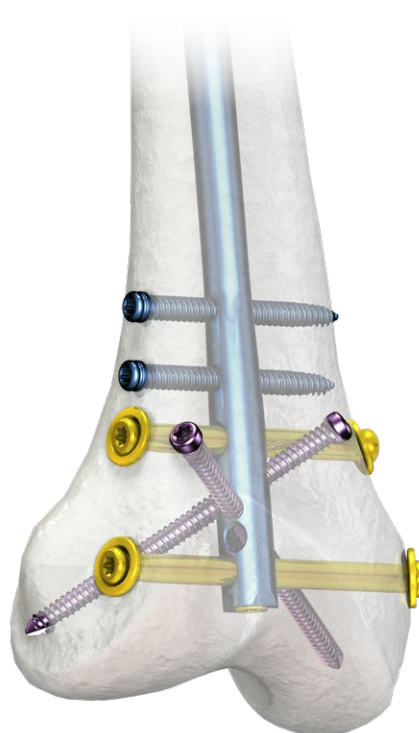

SYMBOLS DESCRIPTION



Pure titanium



Titanium alloy



Steel



Left



Right



Available versions: left/right



Length



Torx drive



Torx drive cannulated



Hexagonal drive



Hexagonal drive cannulated



Cannulated



Locking



Diameter



Inner diameter



Recommended length range for a particular nail



Angle



Available lengths



Available in sterile/ non-sterile condition



Caution - pay attention to a special procedure.



Perform the activity under X-Ray control.



Information about the next stages of a procedure.



Proceed to the next stage.



Return to the specified stage and repeat the activity.



Before using the product, carefully read the Instructions for Use. It contains, among others, indications, contraindications, side effects, recommendations and warnings related to the use of the product.



The above description is not a detailed instruction of conduct. The surgeon decides about choosing the operating procedure.

www.chm.eu

Document No ST/49A
 Date of issue 01.11.2012
 Review date P-006-19.02.2024

The manufacturer reserves the right to introduce design changes.
 Updated INSTRUCTIONS FOR USE are available at the following website: ifu.chm.eu

I. INTRODUCTION	4
II. CONDYLAR NAIL LOCKING OPTIONS	11
II.1. LOCKING USING 6.5 LOCKING SET	12
II.2. LOCKING USING 6.5 SCREWS WITH NUTS	12
II.3. ADDITIONAL LOCKING USING 5.0 OR 5.5 LOCKING SCREWS - LATERAL	13
II.4. ADDITIONAL LOCKING USING 5.0 LOCKING SCREWS - OBLIQUE	13
II.5. ADDITIONAL LOCKING USING 5.0 LOCKING SCREWS - CONDYLAR FROM THE ANTERIOSUPERIOR APPROACH	14
II.6. ADDITIONAL LOCKING USING 5.0 LOCKING SCREWS - CONDYLAR FROM THE CONDYLE	14
III. SURGICAL TECHNIQUE	15
III.1. INTRODUCTION	15
III.2. PREPARATION OF THE TARGETING DEVICE, NAIL INSERTION	20
III.3. CONDYLAR FRAGMENTS REDUCTION USING KIRSCHNER WIRE	24
III.4. LOCKING THE NAIL IN THE CONDYLE OF THE FEMUR	27
III.5. NAIL LOCKING IN THE SHAFT OF THE FEMUR	46
III.6. LOCKING THE NAIL USING 'FREE HAND' TECHNIQUE - METHOD I	50
III.7. LOCKING THE NAIL USING 'FREE HAND' TECHNIQUE - METHOD II	53
III.8. END CAP INSERTION	55
III.9. NAIL REMOVAL	56

I. INTRODUCTION

Reverse nailing of the femur allows for intramedullary fixation of fractures located above the knee joint (*up to 20 cm from its distal end*), and for fixation of multifragmentary fractures of the condyle.

Retrograde nail can also be used when a proximal femoral hip prosthesis or another implant is used.

CHARFIX^{system 2} provides the following femoral retrograde nails sizes: diameter 10, 11, 12 mm and length of 160 - 440 mm.

The presented range of implants is made of materials in accordance with ISO 5832 standard. Compliance with the requirements of quality management systems and the requirements of Directive 93/42/EEC concerning medical devices guarantee high quality of the offered implants.

Depending on the fracture type, to lock the nail in the distal part (*next to the knee*), you may use:

- 2 (two) 6.5 locking screws with nuts or 2 (two) locking sets;
- 2 (two) 5.0/5.5 screws;
- 2 (two) 5.0 screws inserted obliquely.

5 (five) locking sets are available:

- 50 with the regulation range of 50 - 65 mm.
- 60 with the regulation range of 60 - 75 mm.
- 70 with the regulation range of 70 - 85 mm.
- 80 with the regulation range of 80 - 95 mm.
- 90 with the regulation range of 90 - 105 mm.

The locking set comprises a bolt, two washers and a locking screw. To lock the nail in the proximal part, 5.0/5.5 locking screws are used. The nail is shaped as to fit the anatomy of the femur. Each surgery must be carefully planned. In order to determine the fracture and nail size precisely (*diameter and length*), X-Ray images must be taken prior to the surgery. The procedure should be carried out on the operating table with a the patient positioned supine and their leg bent at the knee to 90 degrees. Apply the tourniquet.

Nailing can be performed with or without reaming the medullary canal. In both cases the width of the canal must be bigger than the diameter of the nail used; in the case of reaming the medullary canal, the reaming must be performed along the long axis of the medullary canal to the size of 1.5 - 2 mm greater than the diameter of the nail. In both cases the medullary canal should be widened in the part from the knee using a reamer 13 in size, to a depth of about 6 cm (*diameter of the distal part of the nail is 12 mm*).

CHARFIX2 CONDYLAR RETROGRADE FEMORAL NAIL

CHARFIX *system 2*

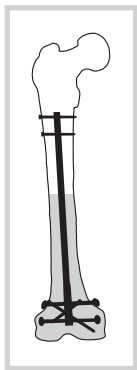
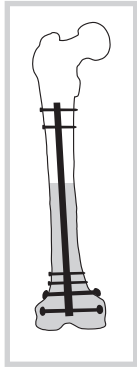
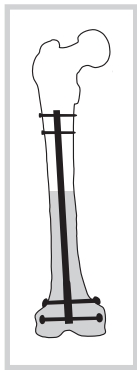

	Len	TiA
10	180	3.5602.180
	200	3.5602.200
	220	3.5602.220
	240	3.5602.240
	260	3.5602.260
	280	3.5602.280
	300	3.5602.300
	320	3.5602.320
	340	3.5602.340
	360	3.5602.360
11	380	3.5602.380
	400	3.5602.400
	420	3.5602.420
	180	3.5603.180
	200	3.5603.200
	220	3.5603.220
	240	3.5603.240
	260	3.5603.260
	280	3.5603.280
	300	3.5603.300
12	320	3.5603.320
	340	3.5603.340
	360	3.5603.360
	380	3.5603.380
	400	3.5603.400
	420	3.5603.420
	180	3.5604.180
	200	3.5604.200
	220	3.5604.220
	240	3.5604.240
260	3.5604.260	
280	3.5604.280	
300	3.5604.300	
320	3.5604.320	
340	3.5604.340	
360	3.5604.360	
380	3.5604.380	
400	3.5604.400	
420	3.5604.420	

available			8 mm ± 19 mm	pitch	1 mm
			160 mm ± 600 mm		5 mm

	TiA					
	3.5158.xxx	✓		6.5	50÷90	
	3.5151.xxx	✓		6.5	50÷120	
	3.5172.000	✓				
	3.5160.xxx	✓	✓	5.5	30÷90	
	3.5159.5xx	✓		5.0	30÷90	
	3.5161.006	✓				

LOCKING ELEMENTS



CHARFIX2 Distal screw 5.0



30	3.5159.530
35	3.5159.535
40	3.5159.540
45	3.5159.545
50	3.5159.550
55	3.5159.555
60	3.5159.560
65	3.5159.565
70	3.5159.570
75	3.5159.575
80	3.5159.580
85	3.5159.585
90	3.5159.590



CHARFIX2 Distal screw 5.5



30	3.5160.030
35	3.5160.035
40	3.5160.040
45	3.5160.045
50	3.5160.050
55	3.5160.055
60	3.5160.060
65	3.5160.065
70	3.5160.070
75	3.5160.075
80	3.5160.080
85	3.5160.085
90	3.5160.090



CHARFIX2 Distal screw 6.5



50	3.5151.050
55	3.5151.055
60	3.5151.060
65	3.5151.065
70	3.5151.070
75	3.5151.075
80	3.5151.080
85	3.5151.085
90	3.5151.090
95	3.5151.095
100	3.5151.100
105	3.5151.105
110	3.5151.110
115	3.5151.115
120	3.5151.120



CHARFIX2 LOCKING SET

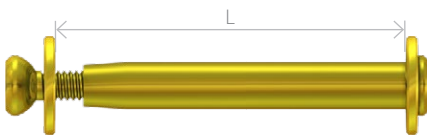

L	Range	
50	50-65	3.5158.050
60	60-75	3.5158.060
70	70-85	3.5158.070
80	80-95	3.5158.080
90	90-105	3.5158.090

CHARFIX2 END CAP M8 SPEC.



3.5161.006

CHARFIX2 NUT 6.5













3.5172.000



































40.5058.200
Stand for CHARFIX2 nail locking elements (set with box without implants)

INSTRUMENT SET FOR FEMORAL CONDYLAR NAILS 40.5860.500

CHARFIX *system 2*

40.5860.500	Name	Pcs	Catalogue no.
	Proximal targeter B	2	40.5861.000
	Nail guide	1	40.5862.000
	Targeter D	1	40.5863.000
	Connecting screw M8x1.25 L=59	1	40.5864.000
	Reconstruction targeter left	1	40.5865.000
	Reconstruction targeter right	1	40.5866.000
	Protective guide 15/13	2	40.5867.000
	Drill guide 13/6.5	1	40.5868.000
	Drill guide 13/5.5	1	40.5869.000
	Wrench for nut	1	40.5870.000
	Protective guide short	1	40.5871.100

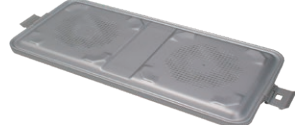
40.5860.500	Name	Pcs	Catalogue no.
	Drill guide short 7/4.0	1	40.6365.000
	Connector M8x1.25/M14	1	40.5873.000
	Femoral trial	1	40.5874.000
	Bolt guide	1	40.5875.000
	Protective guide 13	1	40.5876.000
	Drill 13/4	1	40.5877.000
	Guide 13/4	1	40.5878.000
	Trocar 13	1	40.6374.000
	Guide 7/2	2	40.6373.000
	Set block 9/5.0	2	40.5509.100
	Protective guide 9/7	4	40.5510.200
	Drill guide 7/4	2	40.6339.000
	Trocar 6.5,	1	40.5534.100
	Screwdriver T25	2	40.5575.400
	Wrench S8	1	40.5304.200
	Impactor-extractor	1	40.5308.000
	Screw length measure	1	40.5530.200
	Hole depth measure	1	40.2665.000
	Mallet	1	40.3667.000

40.5860.500	Name	Pcs	Catalogue no.
	Drill with scale 4.0	2	40.5347.002
	Drill with scale 5.5/350	1	40.5340.001
	Drill with scale 6.5/350	1	40.5341.001
	Drill with scale 4.0/150	1	40.5348.002
	Curved awl 8.0	1	40.5523.000
	Nail length measure	1	40.5098.000
	Guide rod handle	1	40.1351.000
	Teflon pipe guide	1	40.1348.000
	Trocar short 7	1	40.1354.100
	Guide rod 3.0/580	1	40.3925.580
	Kirschner wire 2.0/310	4	40.3668.000
	Perforated aluminum lid 1/1 595x275x15mm Gray	1	12.0750.200
	Stand	1	40.5879.500
	Container with solid bottom 1/1 595x275x135mm	1	12.0750.102

II. CONDYLAR NAIL LOCKING OPTIONS

Condylar nail locking options are used to determine the schematic course of the locking elements.

It is possible to combine different methods of locking and change the number of implants.



It is forbidden to combine the oblique and condylar locking options.

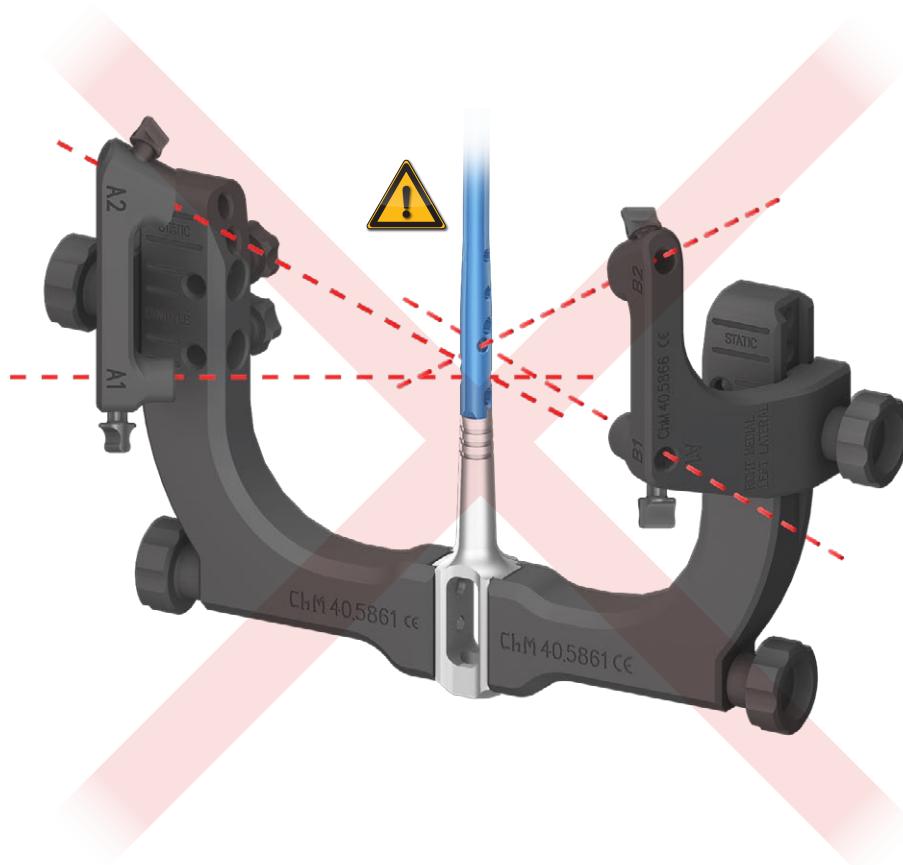

II.1. LOCKING USING 6.5 LOCKING SET

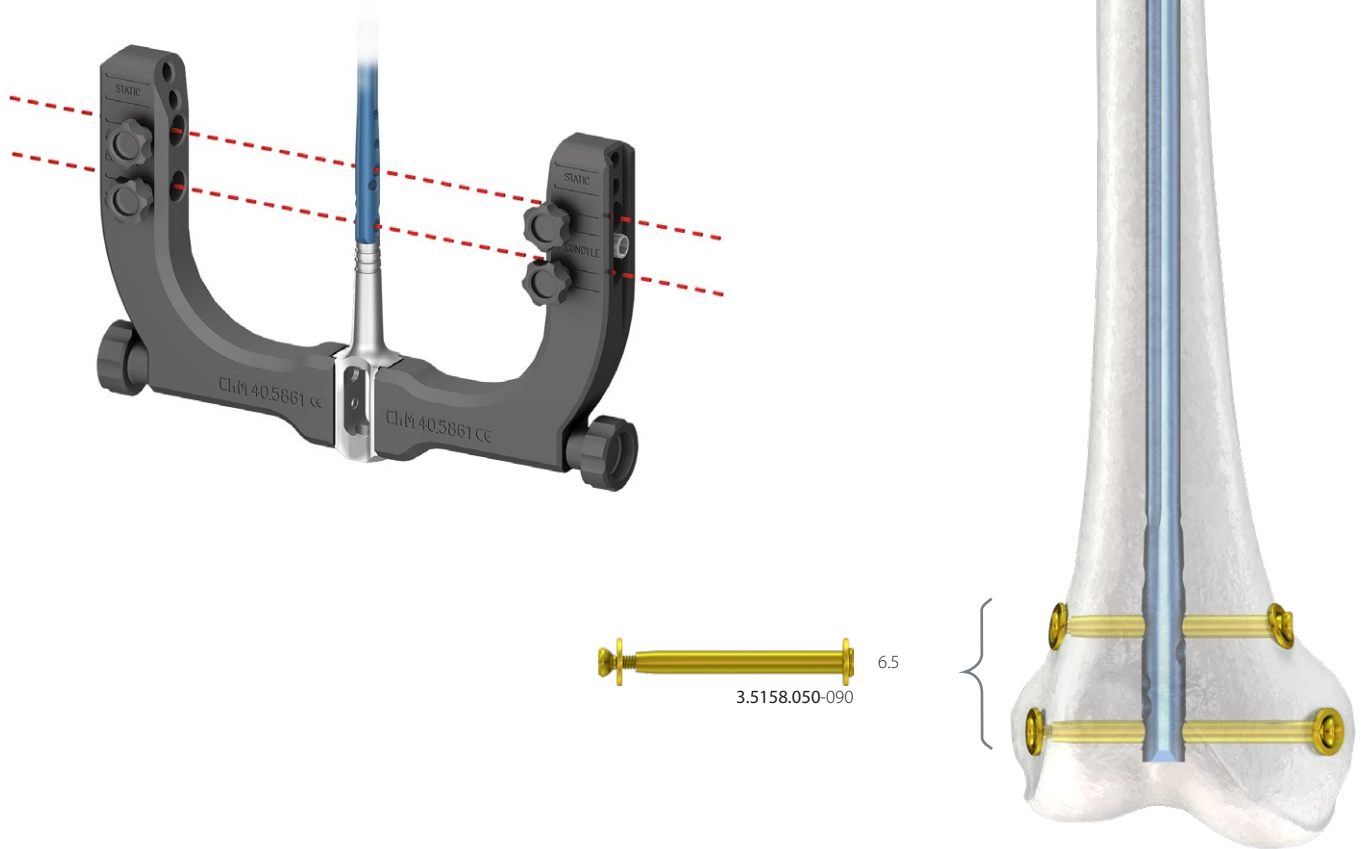

II.2. LOCKING USING 6.5 SCREWS WITH NUTS

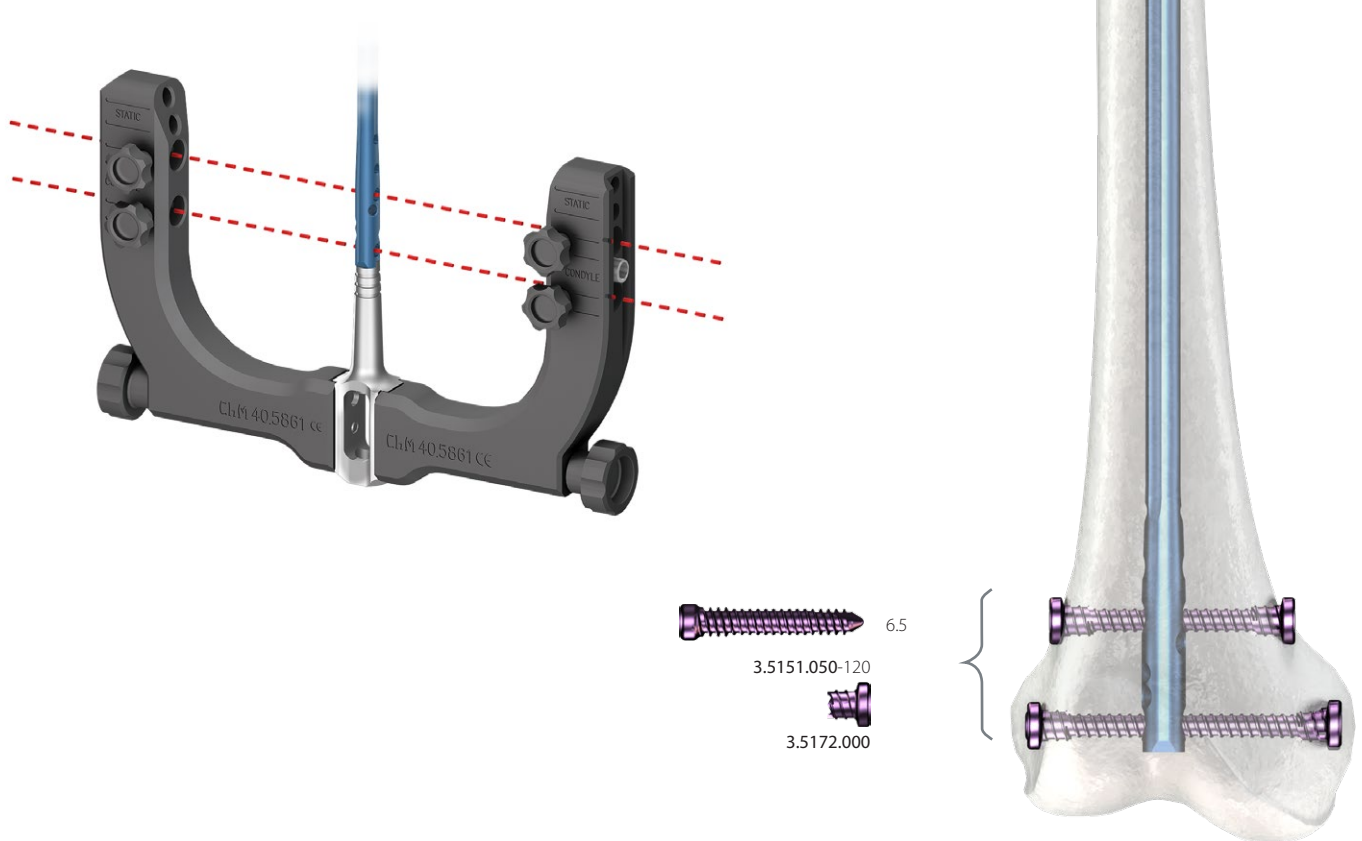

II.3. ADDITIONAL LOCKING USING 5.0 OR 5.5 LOCKING SCREWS - LATERAL

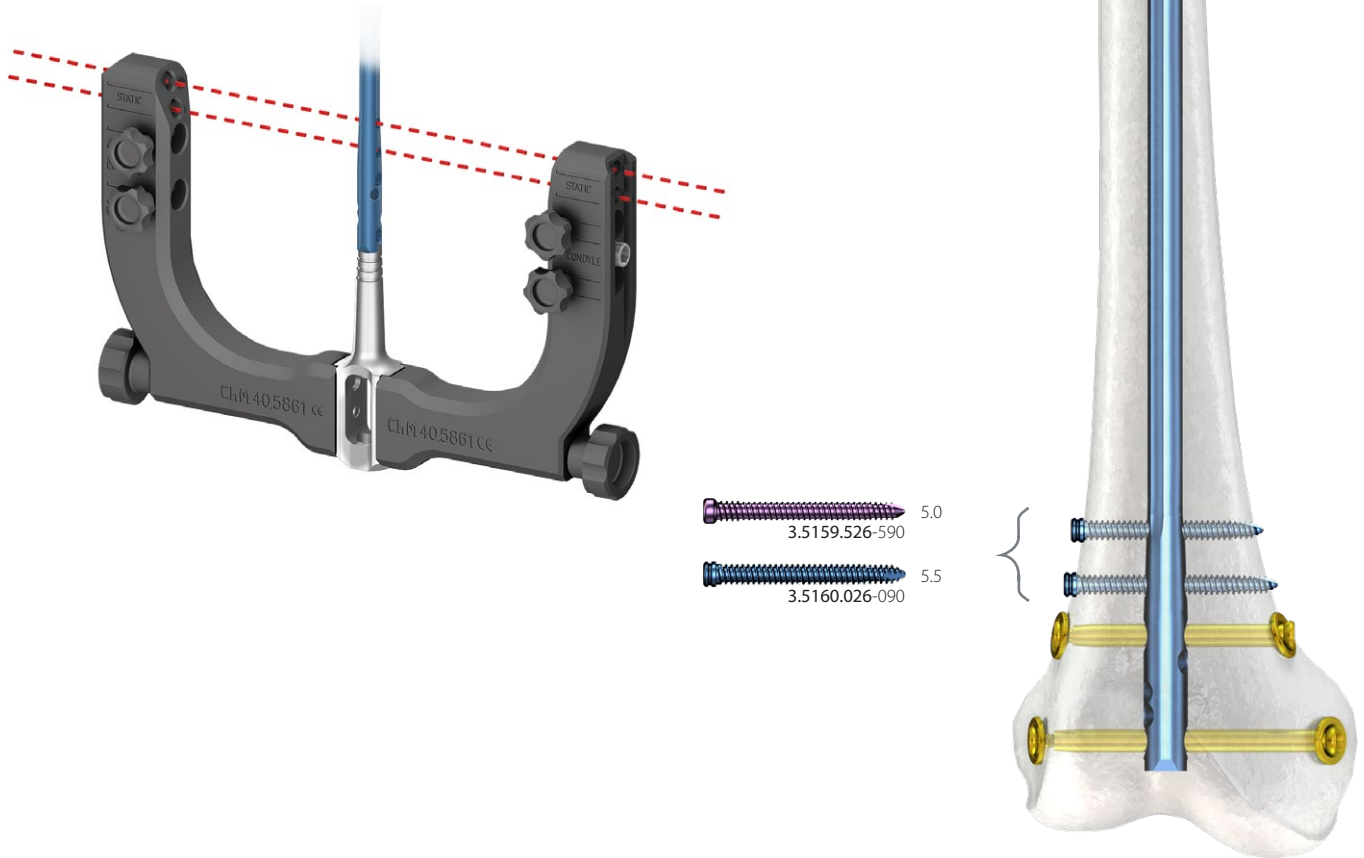

II.4. ADDITIONAL LOCKING USING 5.0 LOCKING SCREWS - OBLIQUE



It is forbidden to combine the oblique and condylar locking options.

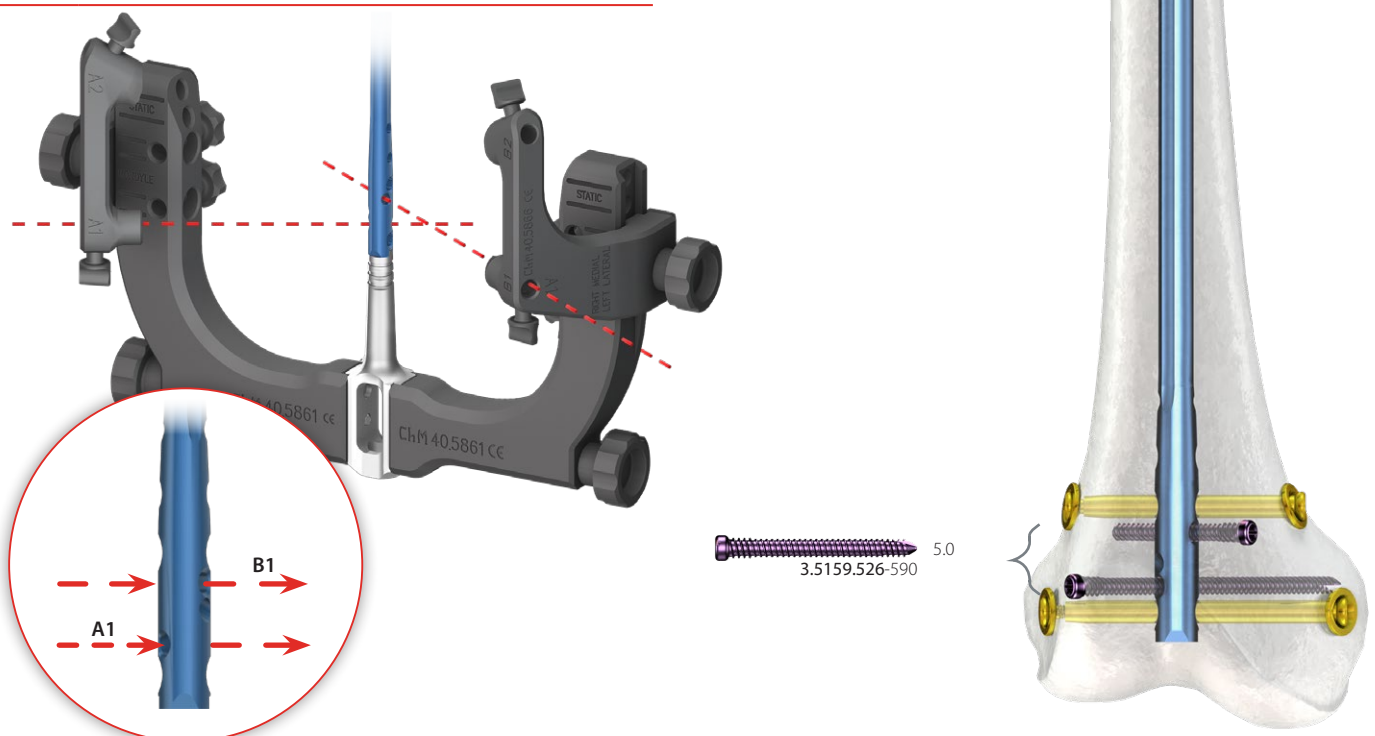

II.5. ADDITIONAL LOCKING USING 5.0 LOCKING SCREWS - CONDYLAR FROM THE ANTERIOSUPERIOR APPROACH



It is forbidden to combine the oblique and condylar locking options.

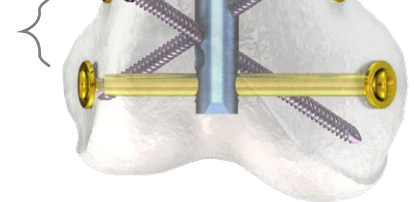
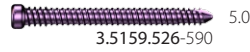
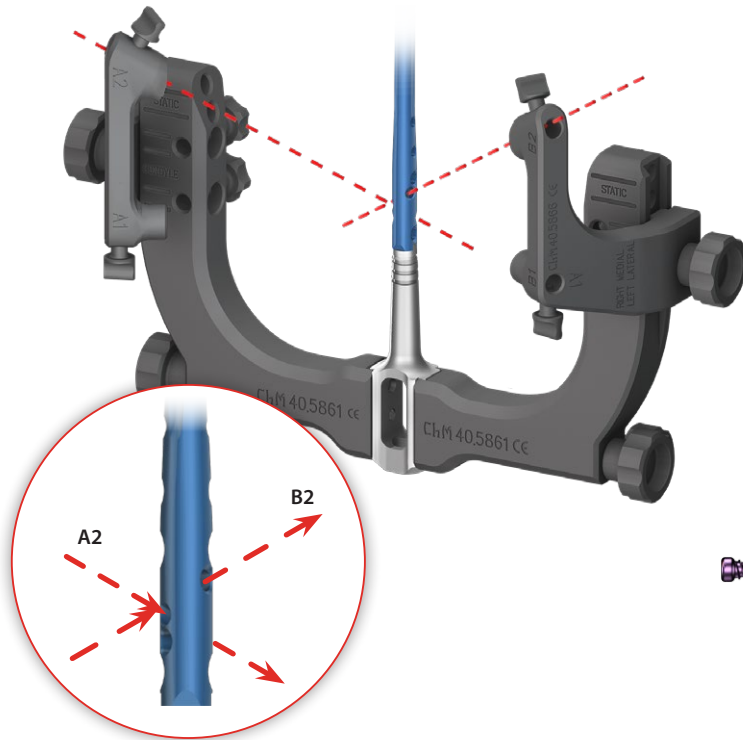

II.6. ADDITIONAL LOCKING USING 5.0 LOCKING SCREWS - CONDYLAR FROM THE CONDYLE



It is forbidden to combine the oblique and condylar locking options.

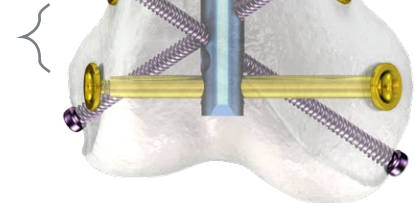
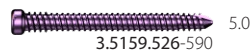
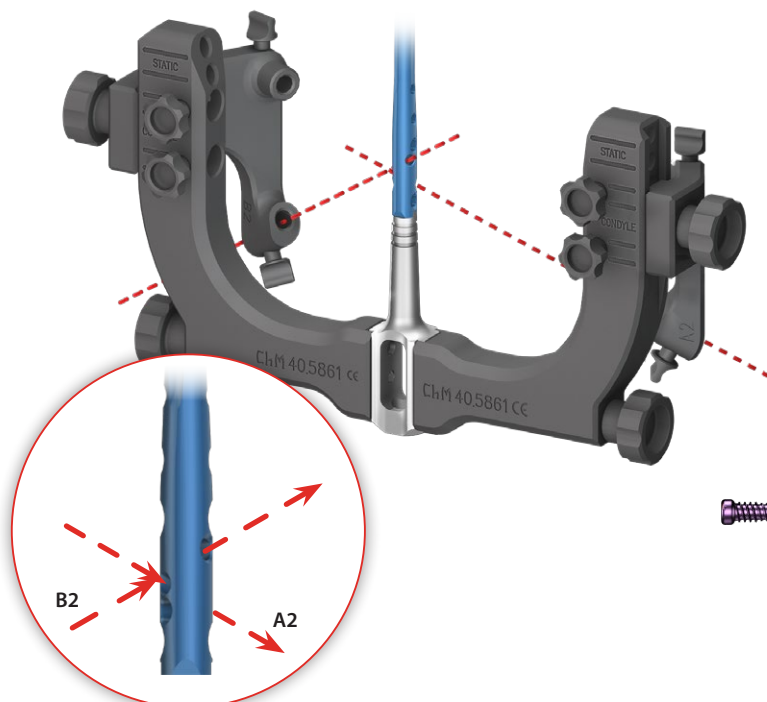

III. SURGICAL TECHNIQUE



The following description depicts the most important steps during the implantation of the intramedullary femoral locking nail; however, it is not a detailed instruction of conduct. It is the surgeon that decides about the surgical technique and its application in each individual case.

III.1. INTRODUCTION

It is suggested to spread the fragments using very strong traction for 2-3 days, unless the patient can be operated on the day the fracture occurs. This will significantly facilitate the fracture reduction and nail insertion. Place the patient on the traction table. Intraoperative radiological examination shall be performed in this intramedullary osteosynthesis.



Each surgical procedure must be carefully planned. Take X-Ray image of the entire femur (*AP and lateral position*) to make sure that no damage to its distal and proximal part has been omitted.

The length and diameter of the nail are chosen on the basis of fractured and healthy femur X-Ray images.

Make incision over the middle of patellar ligament or more paracentrally. Expose intercondylar region (*split the fibers of the ligament or move it laterally*).

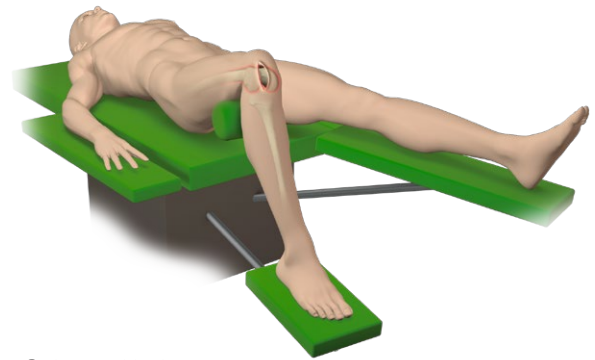
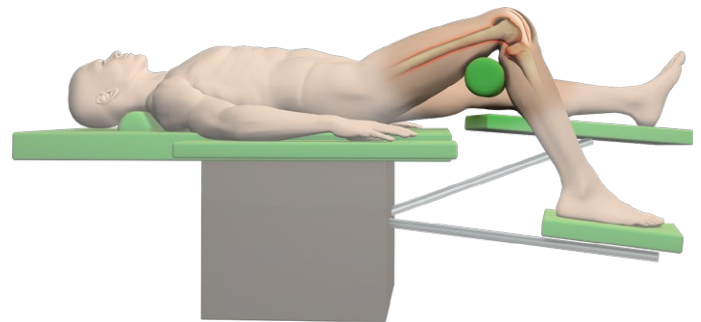

Fig. 1. Patient positioning

1

Having located, mark on the bone the entry point and using a drive, insert the Kirschner wire 2.0/310 [40.3668] into medullary canal.



Control this step with image intensifier.

40.3668.000



- 2 Lean the protective guide 13 [40.5876] and guide 13/4 [40.5878] against the cortical bone.

Remove guide 13/4 [40.5878].

Open the medullary canal using drill 13.0 [40.5877] led on Kirschner wire 2.0/310 [40.3668] in protective guide 13 [40.5876]. Drill slowly until protective guide is reached.

Remove the drill.

Remove the Kirschner wire 2.0/310.

Attach guide rod 3.0/580 [40.3925.580] to the guide rod handle [40.1351] and insert into the protective guide. Guide rod 3.0/580 [40.3925.580] functions as a guide for reamers and a nail.

Remove the protective guide.

Remove the drill.

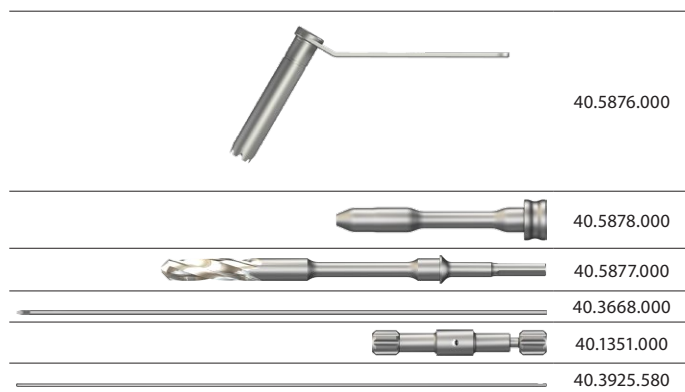

2a Curved awl 8.0 [40.5523] may also be used to open the medullary canal.

When the medullary canal is open, remove the Kirschner wire 2.0/310 [40.3668] and insert guide rod 3.0/580 [40.3925.580] mounted to the guide rod handle [40.1351].

Remove the guide rod handle [40.1351].

Remove the awl.

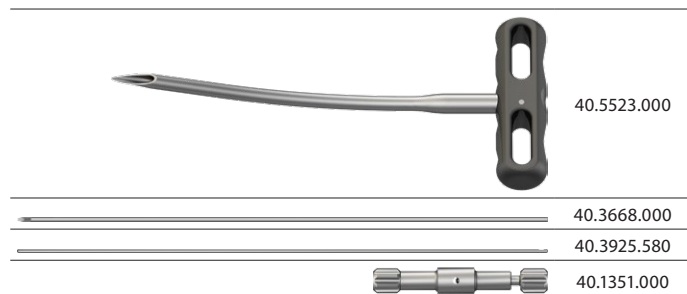

- 3 If medullary canal is reamed, gradually increase the diameter of the canal with steps of 0.5 mm, until the diameter 1.5 to 2.0 mm wider than the diameter of the femoral nail, for the depth at least equal to the nail length is reached.

In both cases, i.e. when the medullary canal is reamed or not, the canal should be reamed using a reamer 13 mm in size to the depth of approx. 6 cm.

Remove the flexible reamer.

NOTE!

Steps 4 and 5 are applicable only if the medullary canal has been reamed or other reamer guides (*guide rods*) not included in the instrument set [40.5860.500] were used. If not applicable, go directly to the step 6.



If the medullary canal is not reamed, in the step 3 ream the distal end of the canal using a reamer of 13 mm in size to the depth of approx. 6 cm and go directly to the step [6].

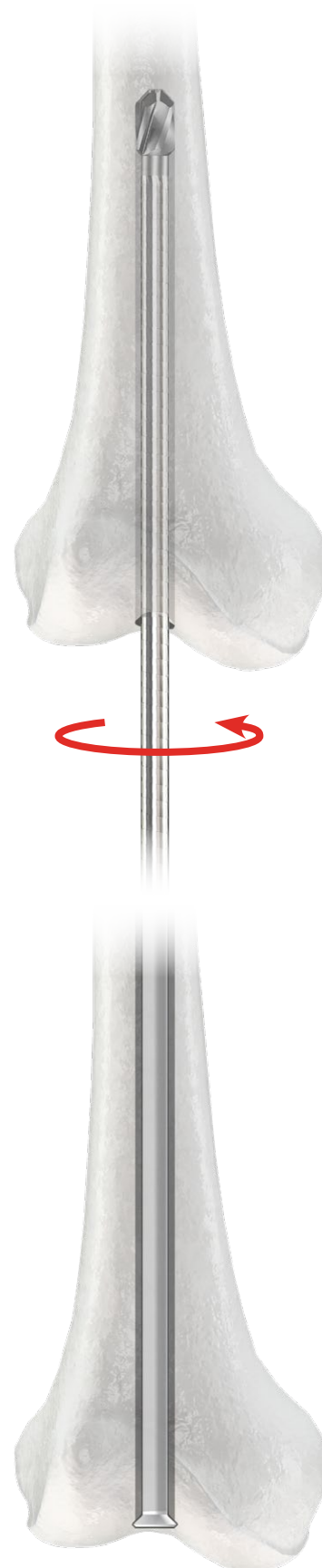

- 4 Introduce the teflon pipe guide [40.1348] onto the flexible reamer guide (*guide rod*) left in the medullary canal.

Remove the flexible reamer guide.



- 5 Mount the guide rod 3.0/580 [40.3925.580] to the guide rod handle [40.1351] and advance it into the teflon pipe guide until its tip reaches the proximal epiphysis.

Remove guide rod handle [40.1351].
Remove teflon pipe guide [40.1348].

	40.3925.580
	40.1351.000
	40.1348.000

- 6 Use the guide rod 3.0/580 to insert the nail length measure [40.5098] until it reaches the end of the bone.

Read the length of the nail.

Remove nail length measure. Remove guide rod, should a solid nail be chosen.



Medullary canal has been prepared for nailing.

	40.3925.580
	40.5098.000

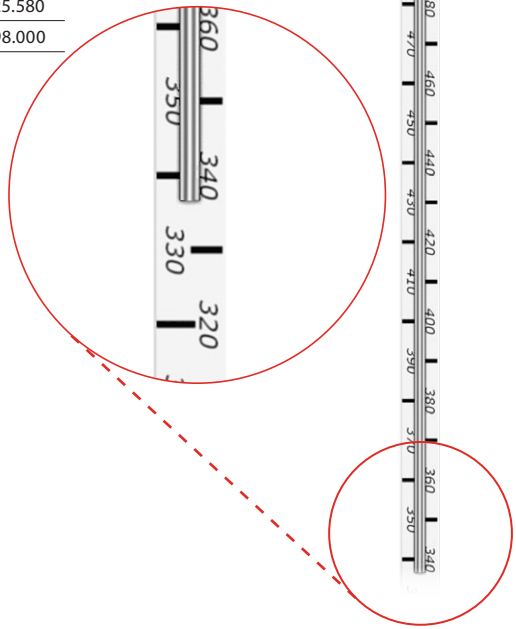

III.2. PREPARATION OF THE TARGETING DEVICE, NAIL INSERTION



There are two proximal targeters B [40.5861] in the condylar targeter set. This allows for the insertion of locking elements from both sides of the nail what is particularly useful when locking sets and 6.5 locking screws with nuts are used. To position the slider of the targeter, only one proximal targeter B may be used that is mounted laterally to the outer bone.



- 7 Using connecting screw M8x1.25 L=59 [40.5864] and wrench S8 [40.5304.200], attach the nail to nail guide [40.5862].

Mount the proximal targeter B to the nail guide [40.5862] from the outer side of the femur.

Make sure the nail is correctly attached.

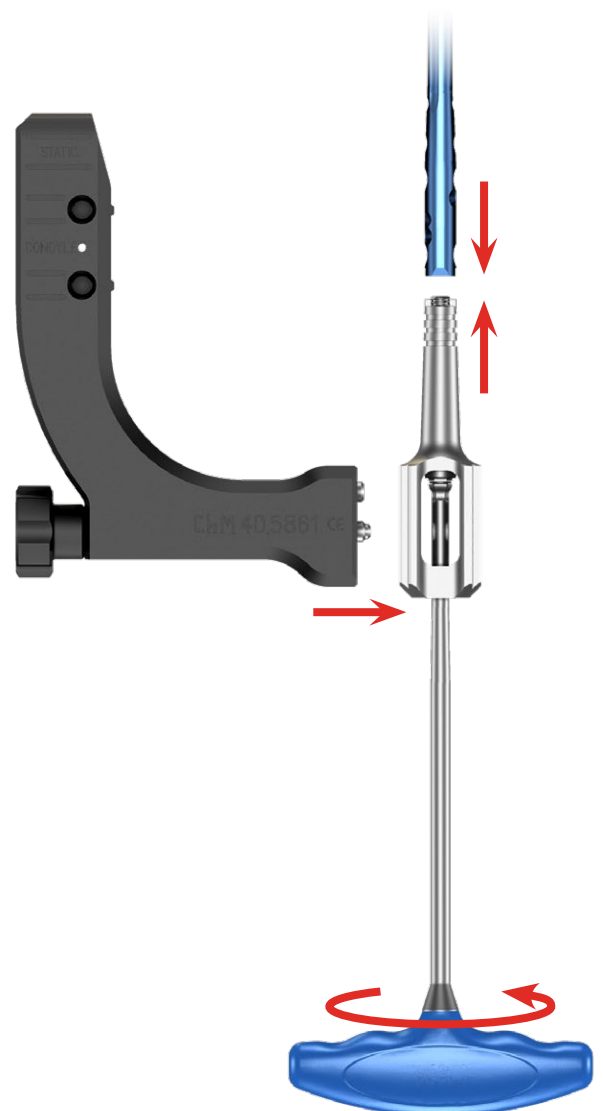

Attach the reconstruction targeter left [40.5865] or right [40.5866].

Insert the set block 9/5.0 [40.5509.100] in the hole of reconstruction targeter used for condylar locking and make sure it corresponds with the nail hole.

Should there be no corresponding nail hole for the set block, rotate the nail removing proximal targeter B [40.5861], rotate nail guide [40.5862] and attach from the other side.

Make sure again the nail is correctly attached.

Remove reconstruction targeter.



40.5865.000



40.5866.000



40.5509.100



40.5861.000



40.5862.000



8 Attach targeter D [40.5863] to proximal targeter B [40.5861].

Using two set blocks, set the slider of the targeter D so as it corresponds to the nail locking holes in the shaft part.

Lock the slider using screwdriver T25 [40.5575.400].



Properly set and secured slider allows for smooth setting of the set block into the nail holes.

Remove set blocks [40.5509.100] from targeter D slider.

Remove targeter D [40.5863] from proximal targeter B.

Remove proximal targeter B [40.5861] from nail guide.

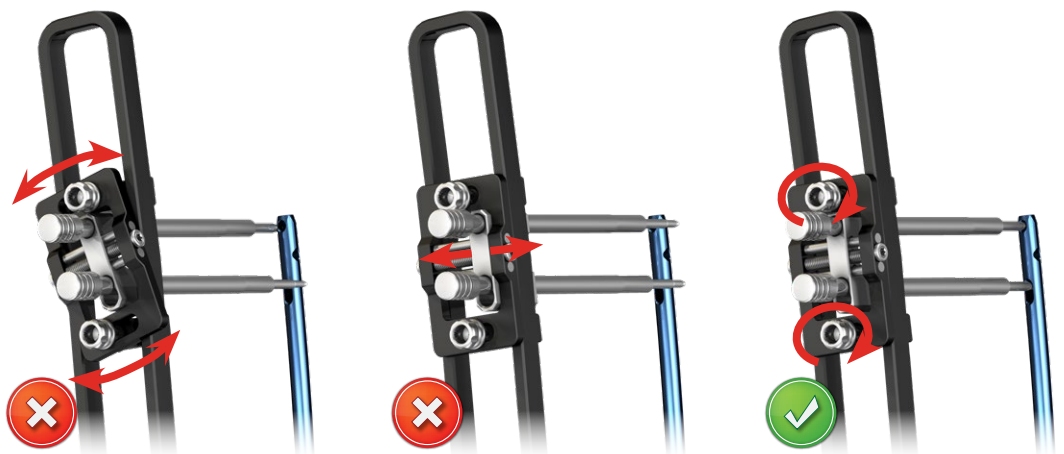
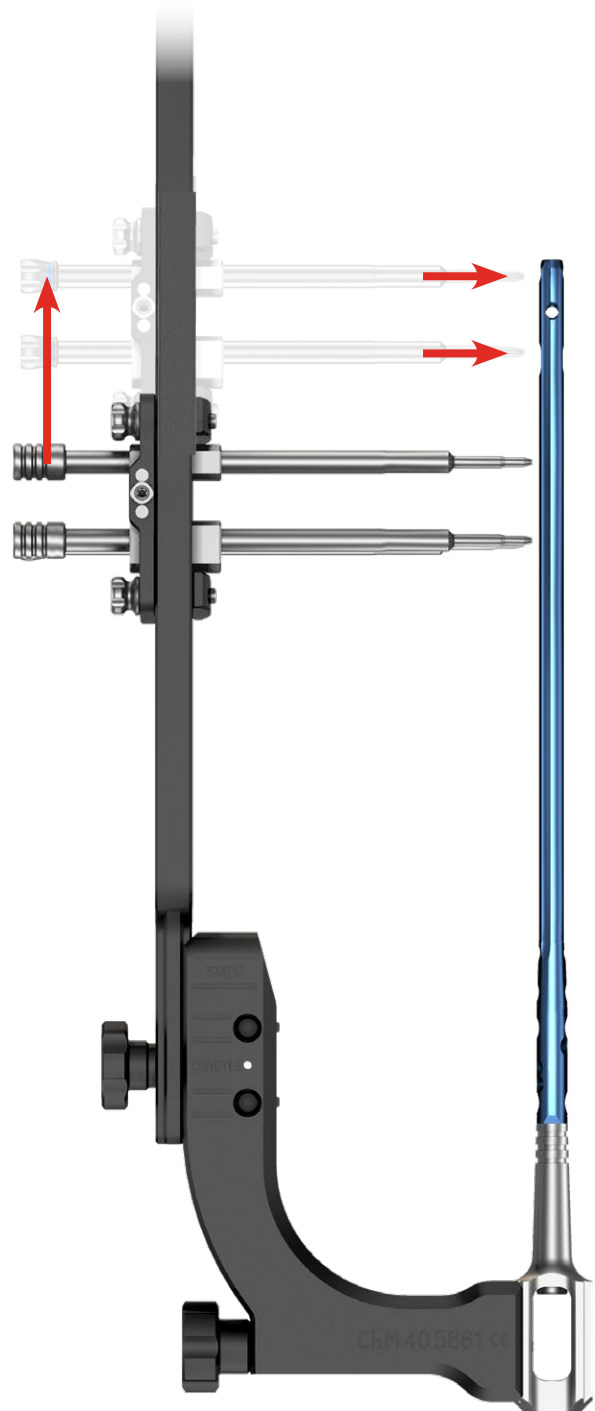
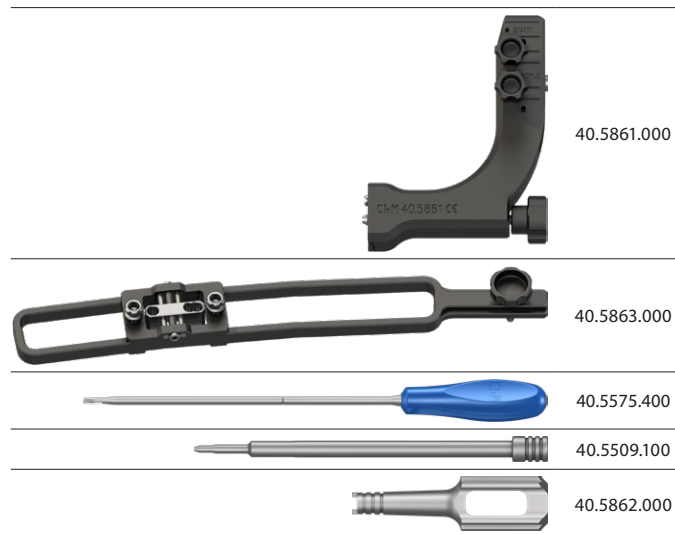

- 9 Attach impactor-extractor [40.5308] to the nail guide [40.5862] with attached nail.

Insert the nail on guide rod 3.0/580 [40.3925.580] left in the medullary canal.

Using mallet [40.3667], insert the nail at the desired depth.

Remove guide rod 3.0/580 [40.3925.580].

Remove impactor-extractor [40.5308] from proximal targeter B.

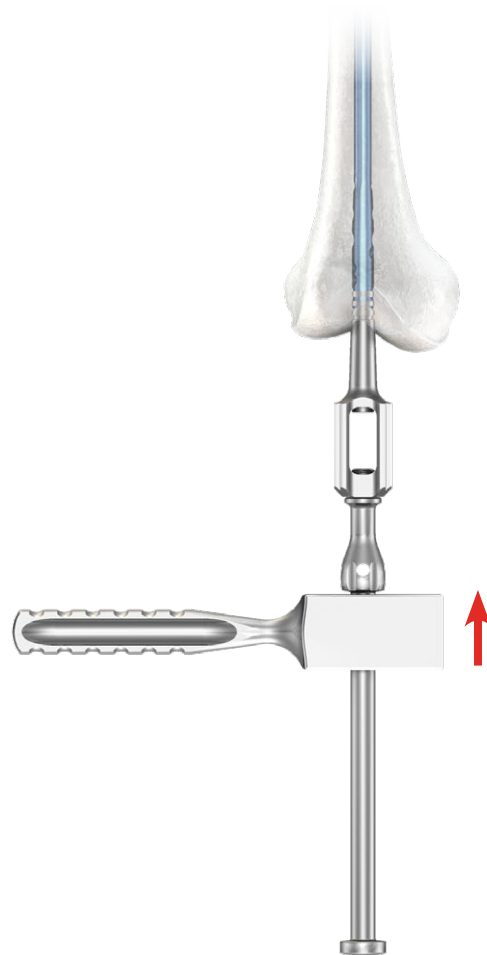
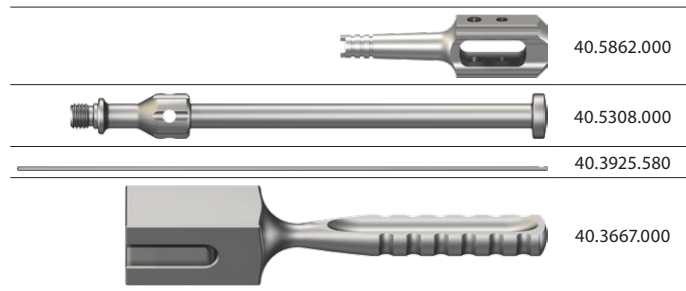

III.3. CONDYLAR FRAGMENTS REDUCTION USING KIRSCHNER WIRE



Bone fragments may be initially reduced using Kirschner wire and holes:

- oblique A1, B1 or
- condylar A2, B2.

10 Attach 2 (two) proximal targeters B [40.5861] to nail guide [40.5862].

Attach reconstruction targeters [40.5865] and [40.5866] to the proximal targeters B [40.5861].



40.5862.000



40.5861.000



40.5865.000



40.5866.000

Reconstruction targeter left [40.5865]:

- for right extremity - RIGHT LATERAL
- for left extremity - LEFT MEDIAL,

Attach one of the targeters opposite to the other to achieve best stabilization.

Reconstruction targeter right [40.5866]:

- for right extremity - LEFT MEDIAL,
- for left extremity - RIGHT LATERAL.

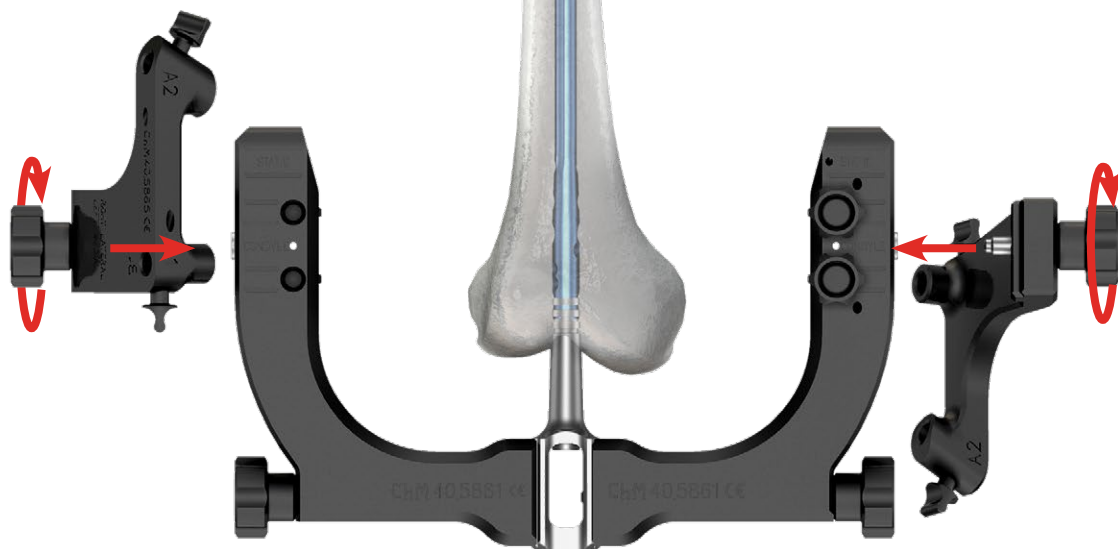

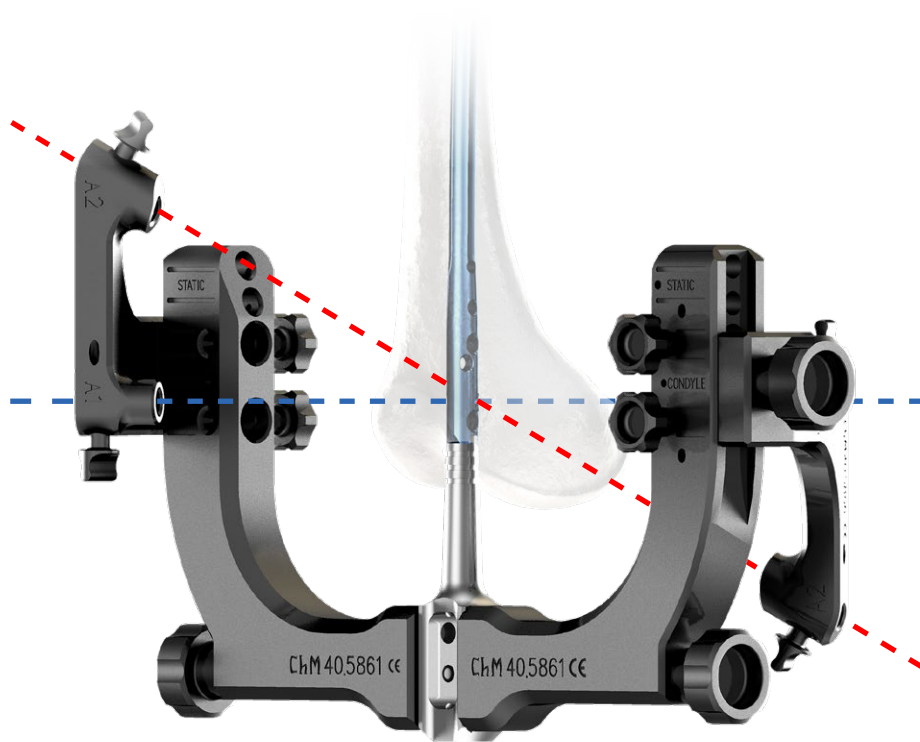

Due to the implant design, it is possible to insert Kirschner wire or locking screw:

- only in one oblique or condylar hole at A1-A2 level,
- only in one oblique or condylar hole at B1-B2 level.

- 11 Insert trocar 6.5 [40.5534.100] and protective guide 9/7 [40.5510.200] in the reconstruction targeter hole. Mark on the skin the entry point for the locking screw and perform the incision at the length of about 1.5 cm. Insert the protective guide with trocar through the incision as close to the cortical layer as possible. Using trocar, mark the entry point for Kirschner wire.

Remove trocar.

Lock protective guide in the hole of the targeter using the handwheel.

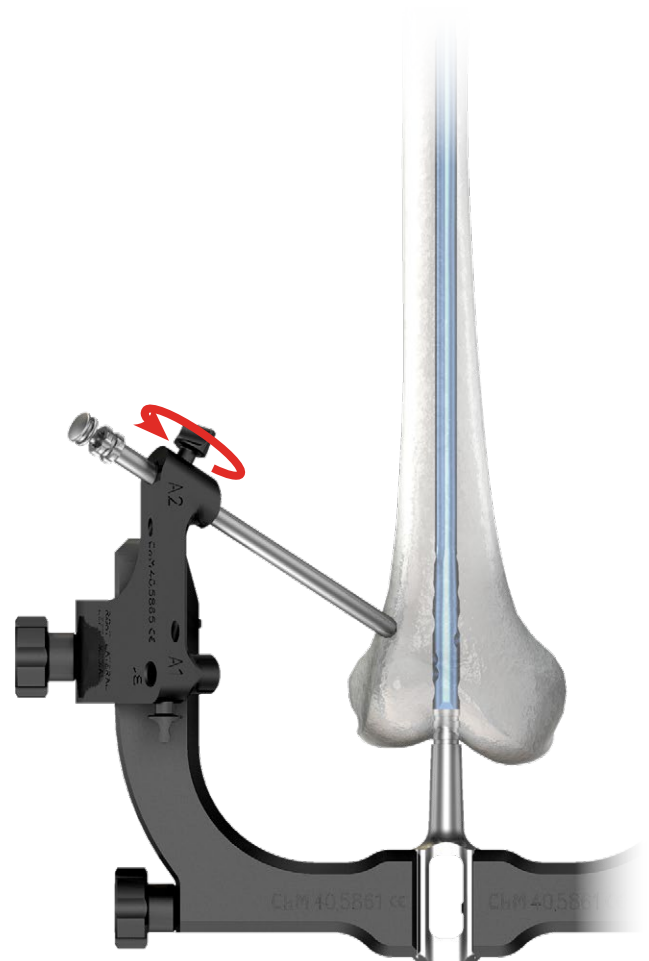

12 Insert trocar 6.5 [40.5534.100] and protective guide 9/7 [40.5510.200] in the hole of the other reconstruction targeter. Mark on the skin the entry point for the locking screw and perform the incision at the length of about 1.5 cm. Insert the protective guide with trocar through the incision as close to the cortical layer as possible. Using trocar, mark the entry point for Kirschner wire.

Remove trocar.
Lock protective guide in the hole of the targeter using the handwheel.

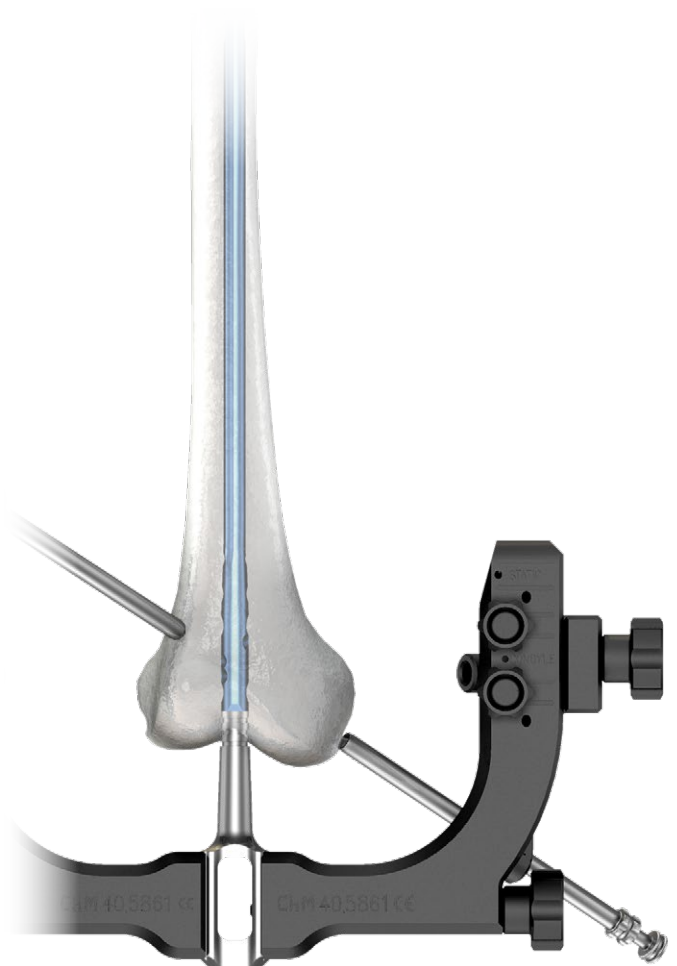
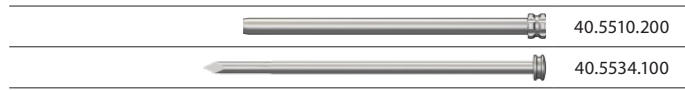

13 Insert guide 7/2 [40.6373] into protective guide 9/7 [40.5510.200]. Using a drive, insert Kirschner wire 2.0/310 [40.3668] in the condylar bone fragments.



This step should be performed under the X-Ray control with video channel.

Remove protective guide.
Remove guide 7/2.
Remove reconstruction targeters.

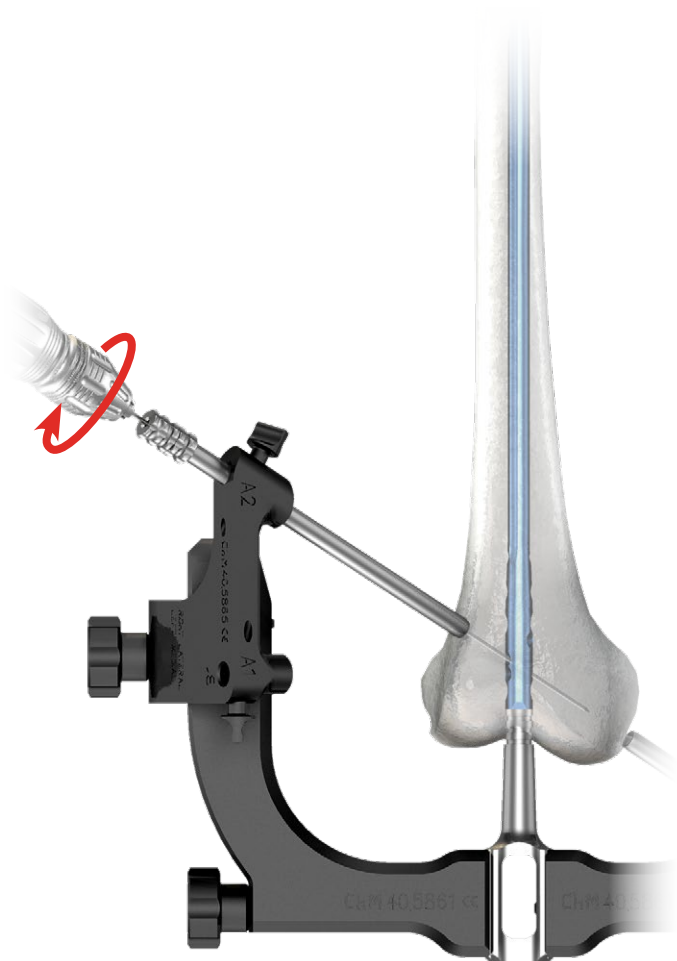
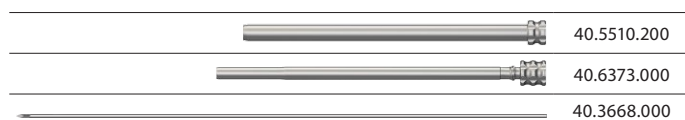

III.4. LOCKING THE NAIL IN THE CONDYLE OF THE FEMUR

III.4.1. Locking using 6.5 locking set

14 Attach proximal targeters B [40.5861] (2 pcs.) to the nail guide [40.5862]. Introduce protective guides 15/13 [40.5867] in the holes marked CONDYLE of both targeters. Insert laterally drill guide 13/6.5 [40.5868]. Using a drive and drill with scale 6.5/350 [40.5341.001], perform through a hole for the locking set.



This step should be performed under the X-Ray control with video channel.



The value on the scale of the drill, **reduced by 10 mm**, determines the parameter acc. to which the size of the locking set should be selected.

Remove the drill.

Remove drill guide 13/6.5 [40.5868].

Protective guides 15/13 [40.5867] shall be left in the targeters holes.

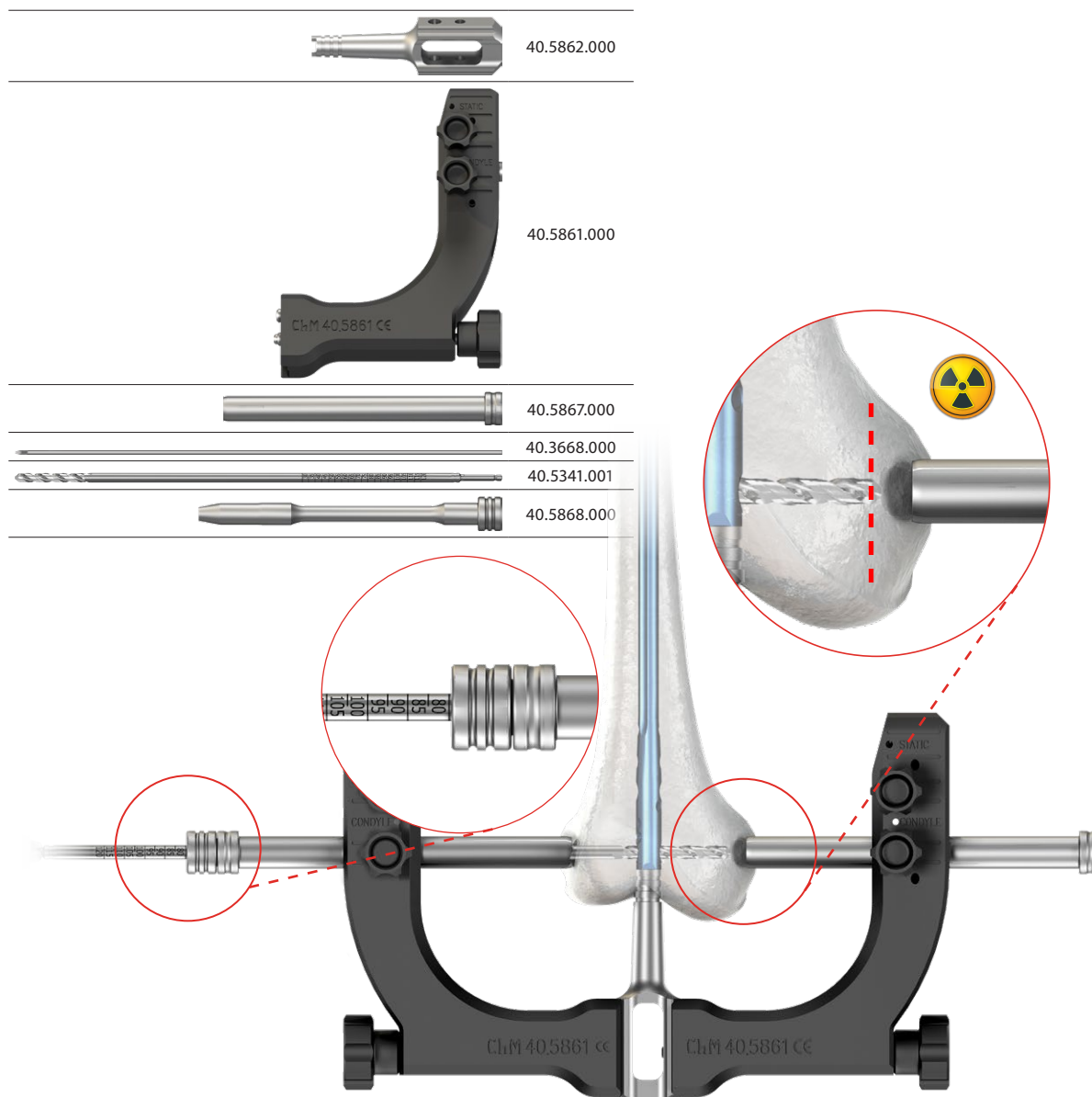

- 15 Using protective guide 15/13 [40.5867], insert screw length measure [40.5530.200] until its hook reaches the end of the hole. The tip of the guide should be in contact with the outer cortex of the femur while measuring.

The value on the scale of the drill, **reduced by 10 mm**, determines the parameter acc. to which the size of the locking set should be selected.



The determined parameter must be included in the range of an available locking system, for example, when the measure is '75', the parameter will be '65' - use a locking set of nominal size 60 with the regulation of 60-75mm.

Remove screw length measure.

Protective guides 15/13 [40.5867] shall be left in the targeter's holes.

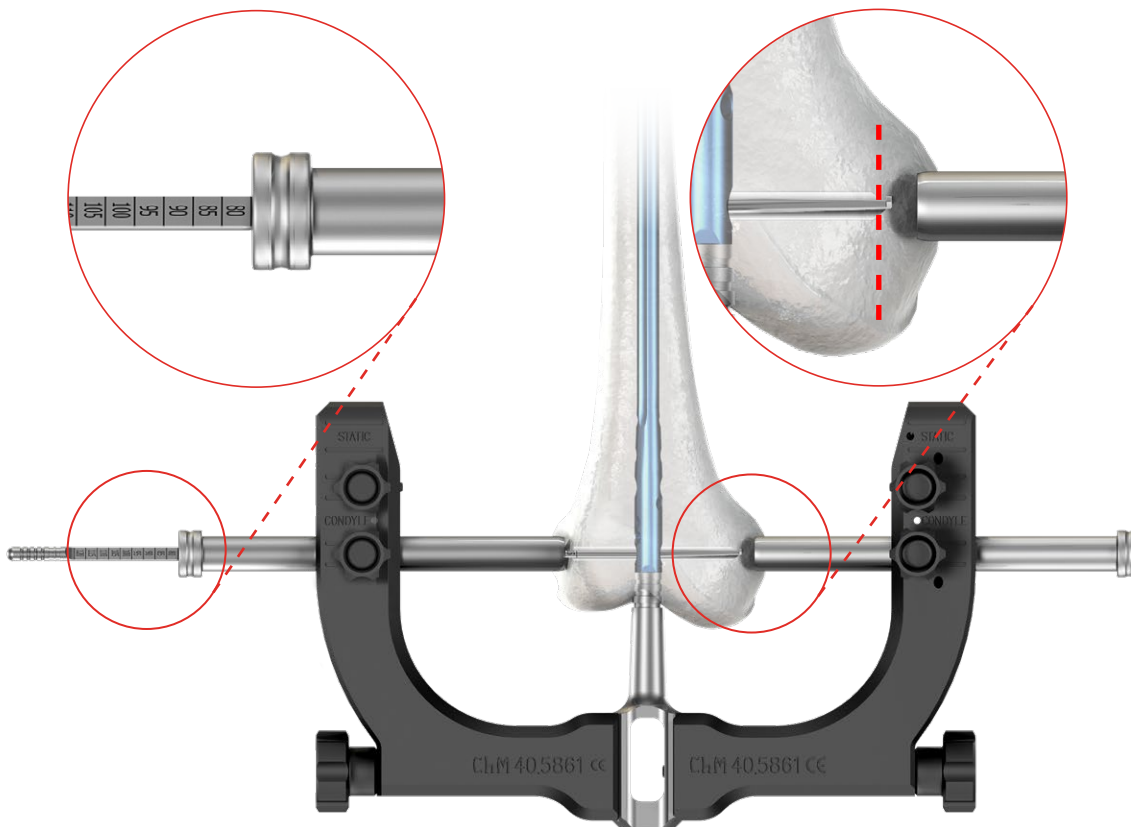
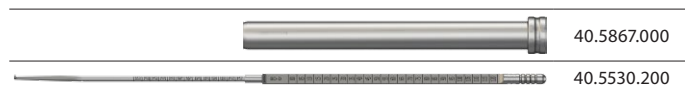

16 Insert bolt guide [40.5875] to the protective guide.

At the tip of the bolt guide, there should be found a pilot which is an integrated part of the guide.

Move bolt guide through the prepared hole in the bone (*the end of the guide must be outside of the channel*).

Remove the pilot.

Attach the washer (*implant*) to the bolt (*implant*) and using screwdriver T25 [40.5575.400], screw it in to the end of the guide. Insert the bolt into the hole in the bone (*head of the bolt should rest, through the washer, against the cortical bone*).

Remove the guide from the bolt and from the protective guide.

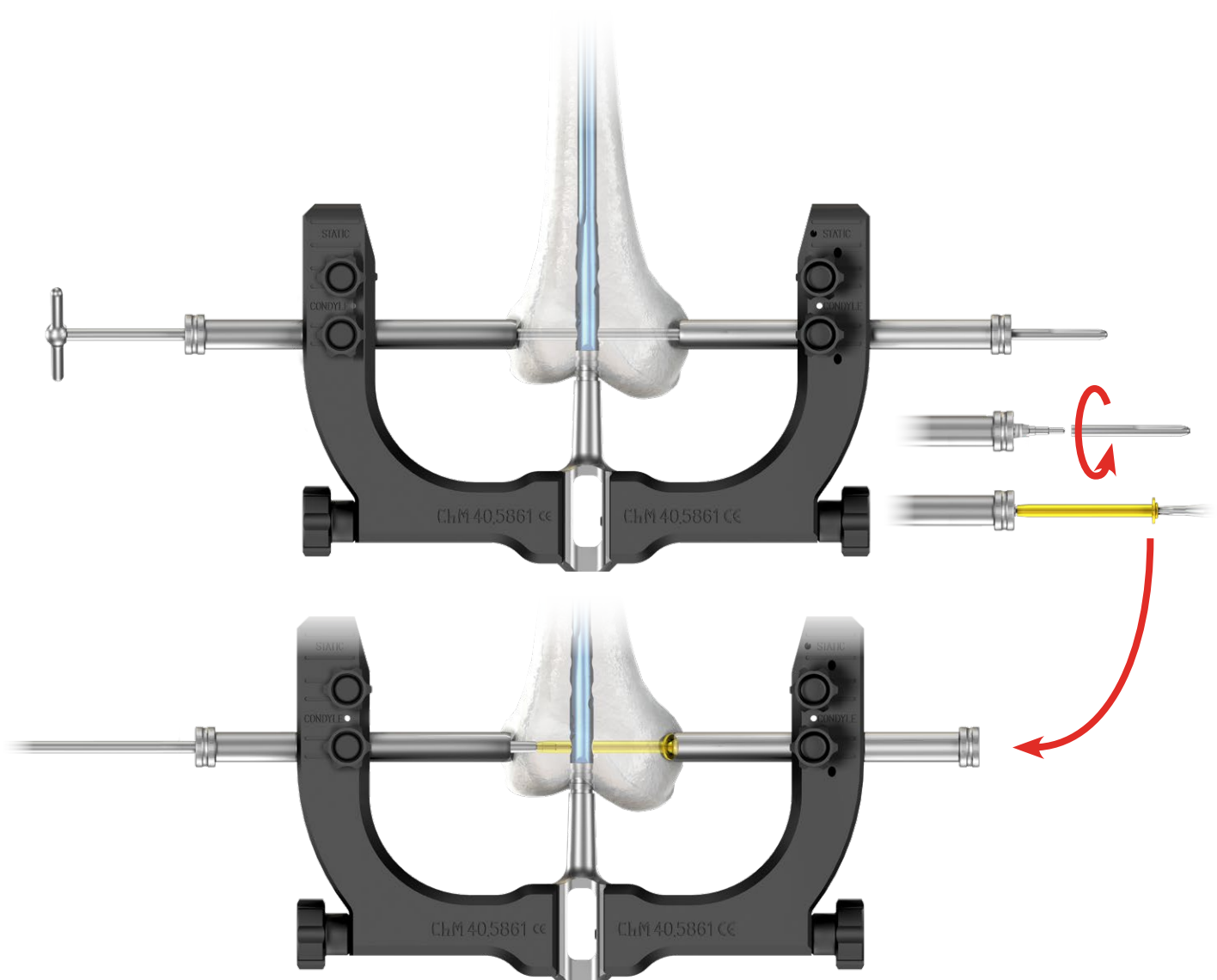
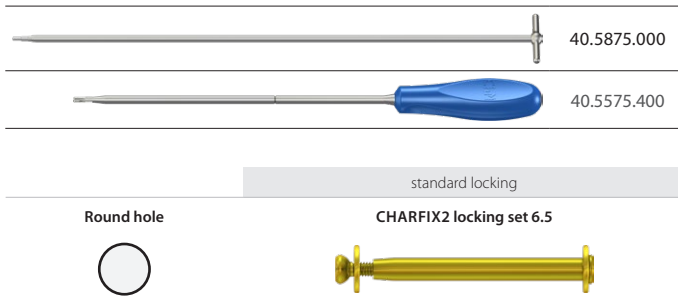

- 17 Insert the screwdriver T25 in the socket of the locking screw (*implant*) with the washer and then insert the set into the protective guide. Screw in the locking screw into the threaded socket of the bolt (*push the bolt with the screwdriver to prevent it from moving*). To lock the locking set (*bolt - two washers - locking screw*), two screwdrivers should be used.

Remove screwdrivers.

Remove protective guides.

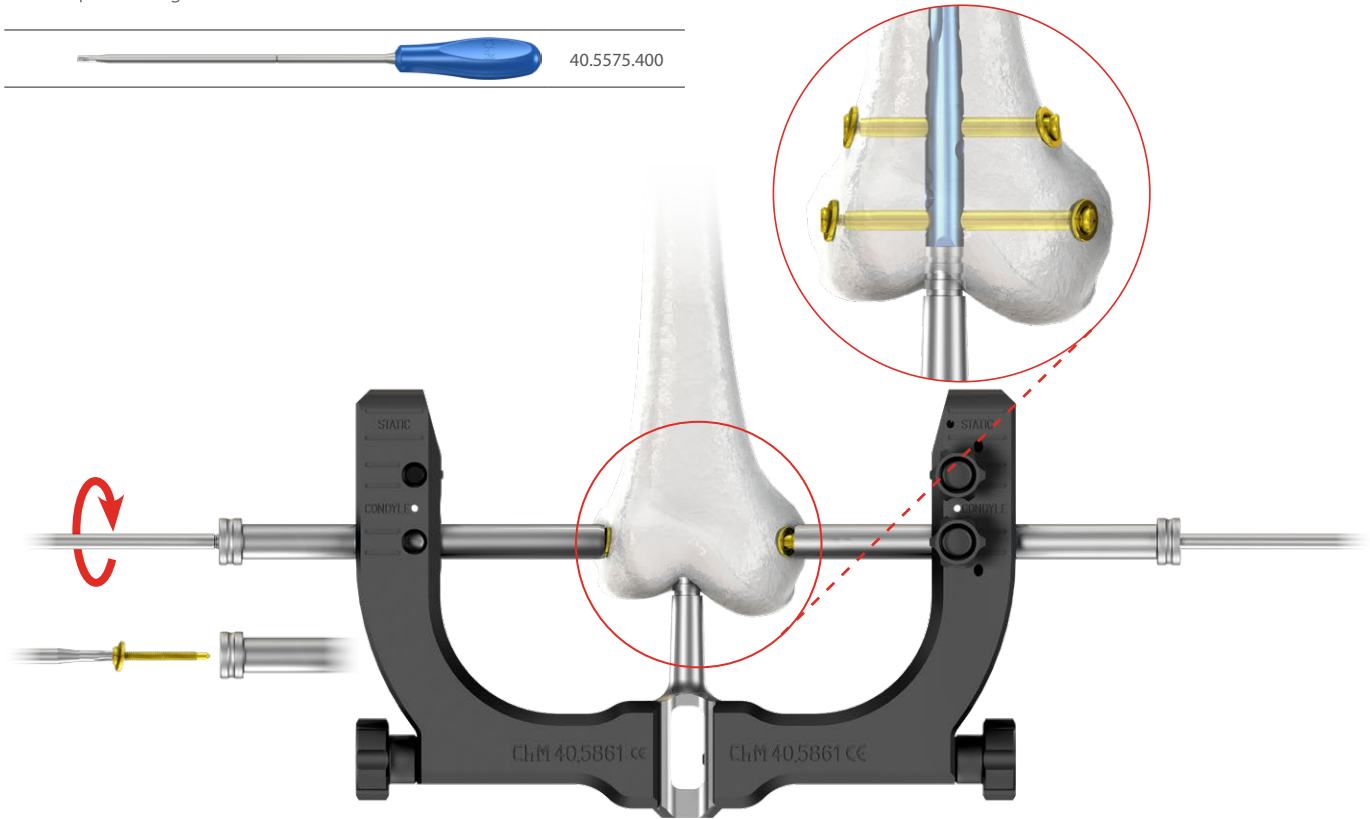

NOTE! To lock the nail in the other distal hole, repeat steps 14-17.

III.4.2. Locking using 6.5 screws with nuts

- 18 Attach two proximal targeters B [40.5861] to the nail guide [40.5862].
Insert protective guides 15/13 with the trocar 13 [40.6374] in the holes marked CONDYLE of the targeters.

Remove the trocar.

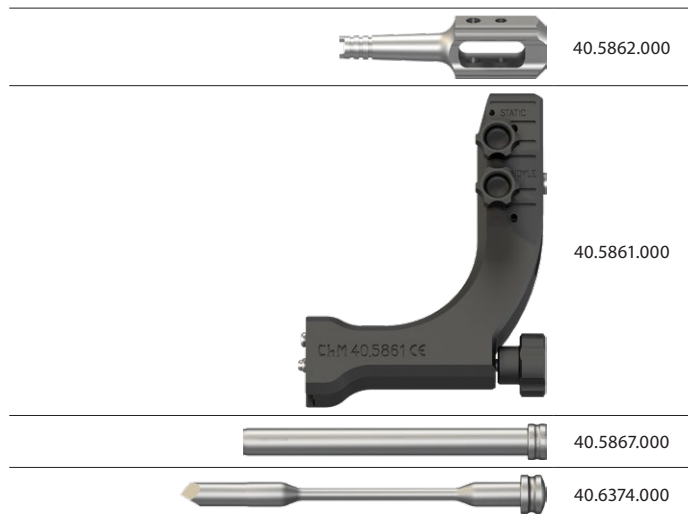

Insert laterally drill guide 13/5.5 [40.5869].

Using a drive and drill with scale 5.5/350 [40.5341.001], perform a hole for the locking screw.



If nuts are to be used for locking screws, choose a locking element of 5 mm longer than intended.



This step should be performed under the X-Ray control with video channel.

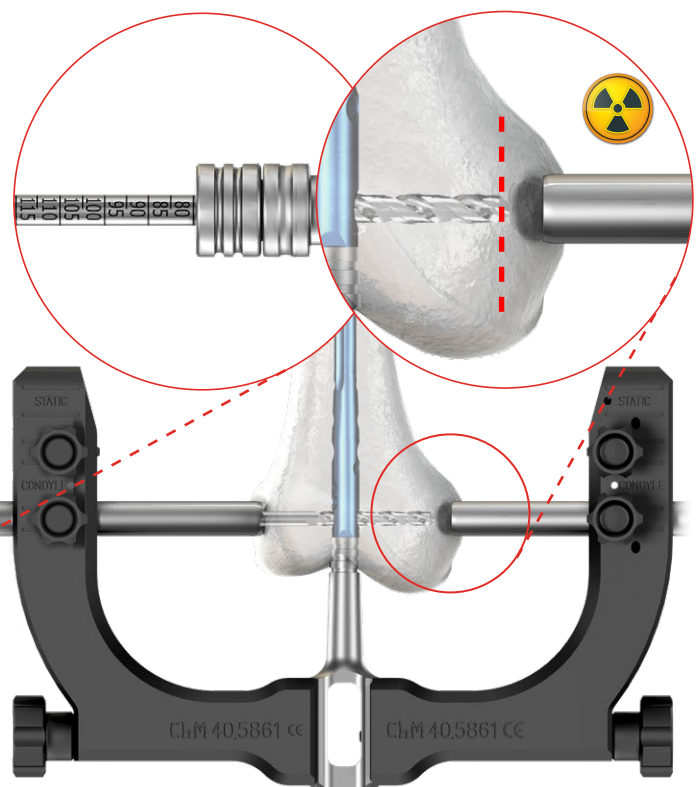

Remove the drill.

Remove the drill guide [40.5869].

Protective guides 15/13 [40.5867] shall be left in the targeters holes.

- 19 Using protective guide 15/13 [40.5867], insert screw length measure [40.5530.200] until its hook reaches the end of the hole. The tip of the guide should be in contact with the outer cortex of the femur while measuring. The scale on the measure indicates the length of the locking element.



If nuts are to be used for locking screws, choose a locking element of 5 mm longer than intended.

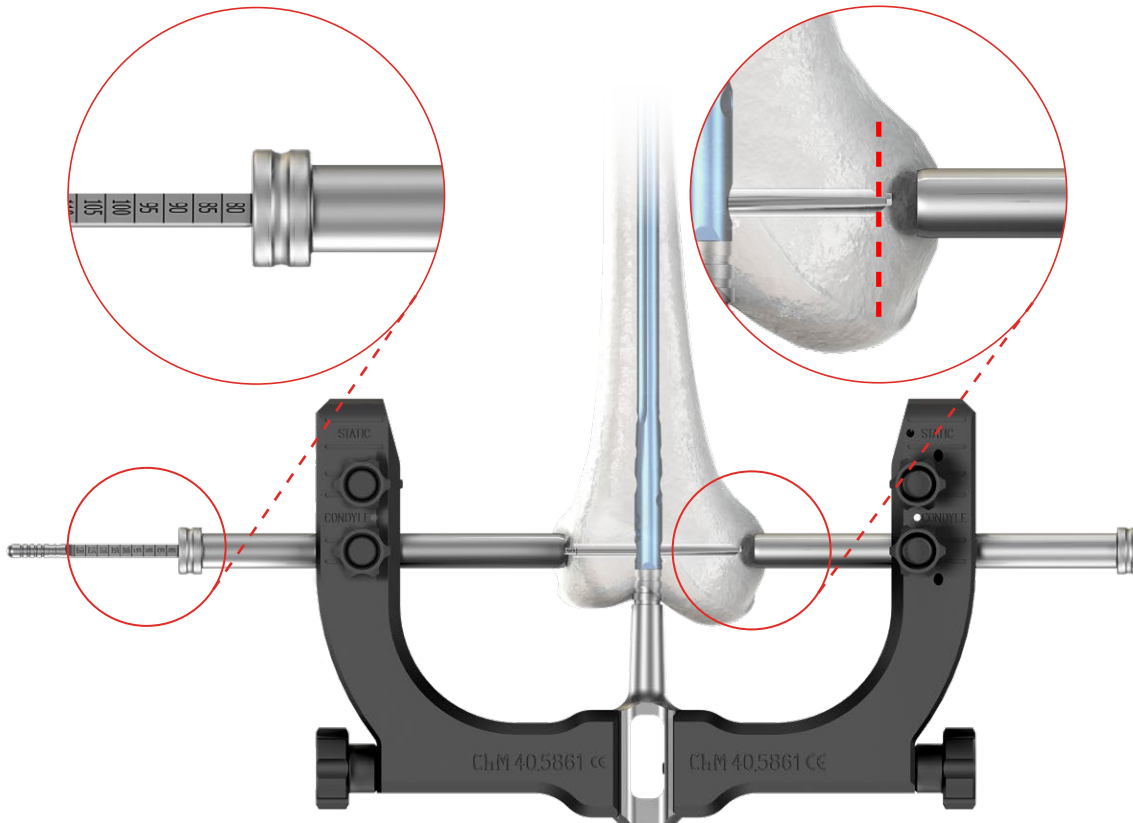

Remove the screw length measure.

Protective guides 15/13 [40.5867] shall be left in the targeter holes.



- 20 Attach wrench for nut [40.5870] to the screwdriver T25 [40.5575.400].
Insert the tip of the screwdriver into the socket of the selected locking screw.
Using wrench for nut [40.5870], apply 6.5 nut [3.5172] (*implant*) to the screw head.
Insert the set into the protective guide.

Insert the locking screw into the prepared hole in the bone, until the screw head reaches the cortex (*when nuts are used, the head should protrude for about 3-5 mm from the bone*). The groove on the screwdriver shaft will align with the end of the protective guide.

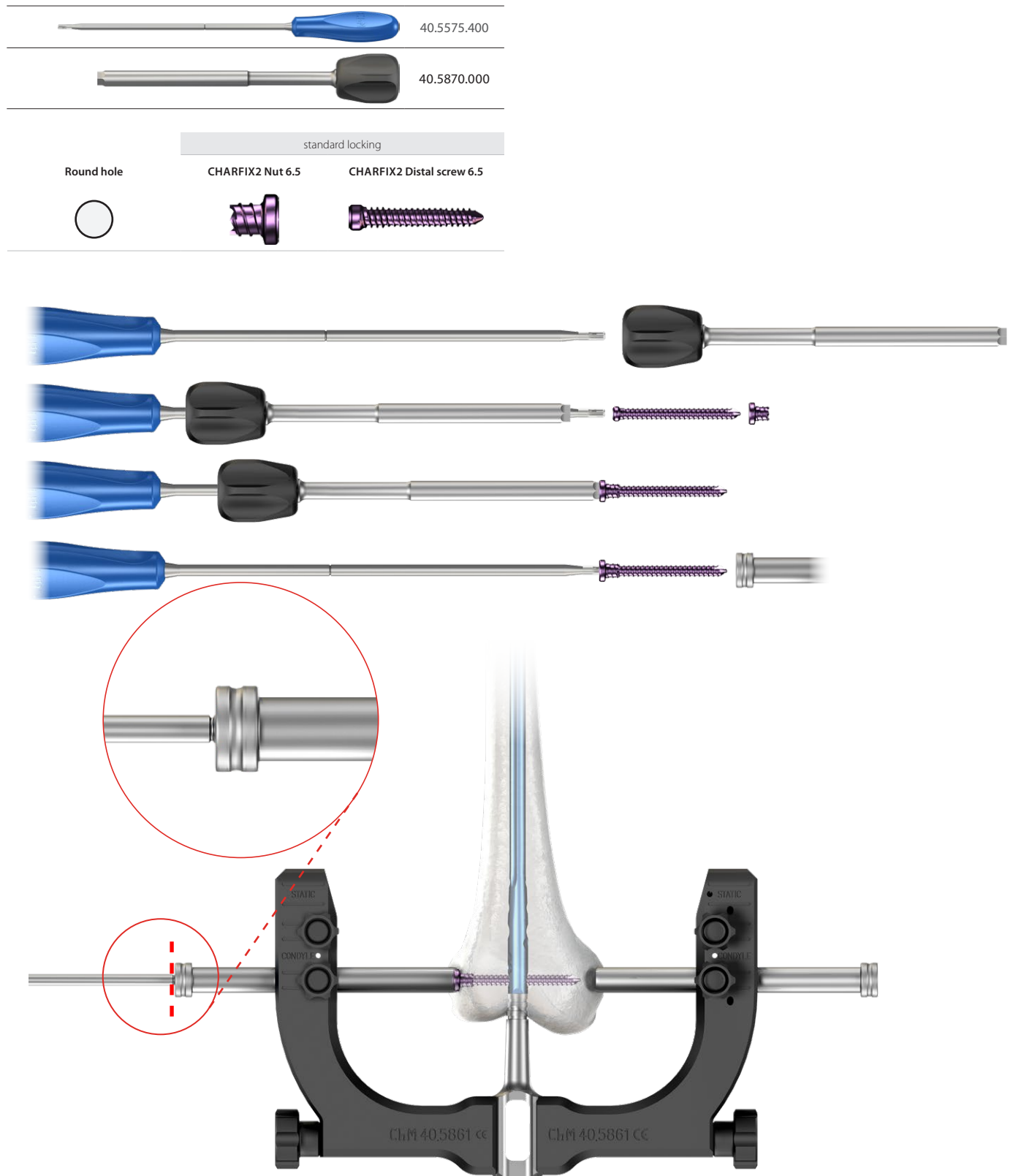

- 21 Insert the tip of the wrench for nut [40.5870] to the head of the 6.5 nut [3.5172] (implant). Insert the set into the protective guide on the other side of the inserted locking screw.

Turning the nut, grasp the thread of the locking screw and tighten until the face of the nut rests on the bone.

To lock the screw and nut, use screwdriver T25 [40.5575.400] and wrench for nut [40.5870].

Remove protective guides.

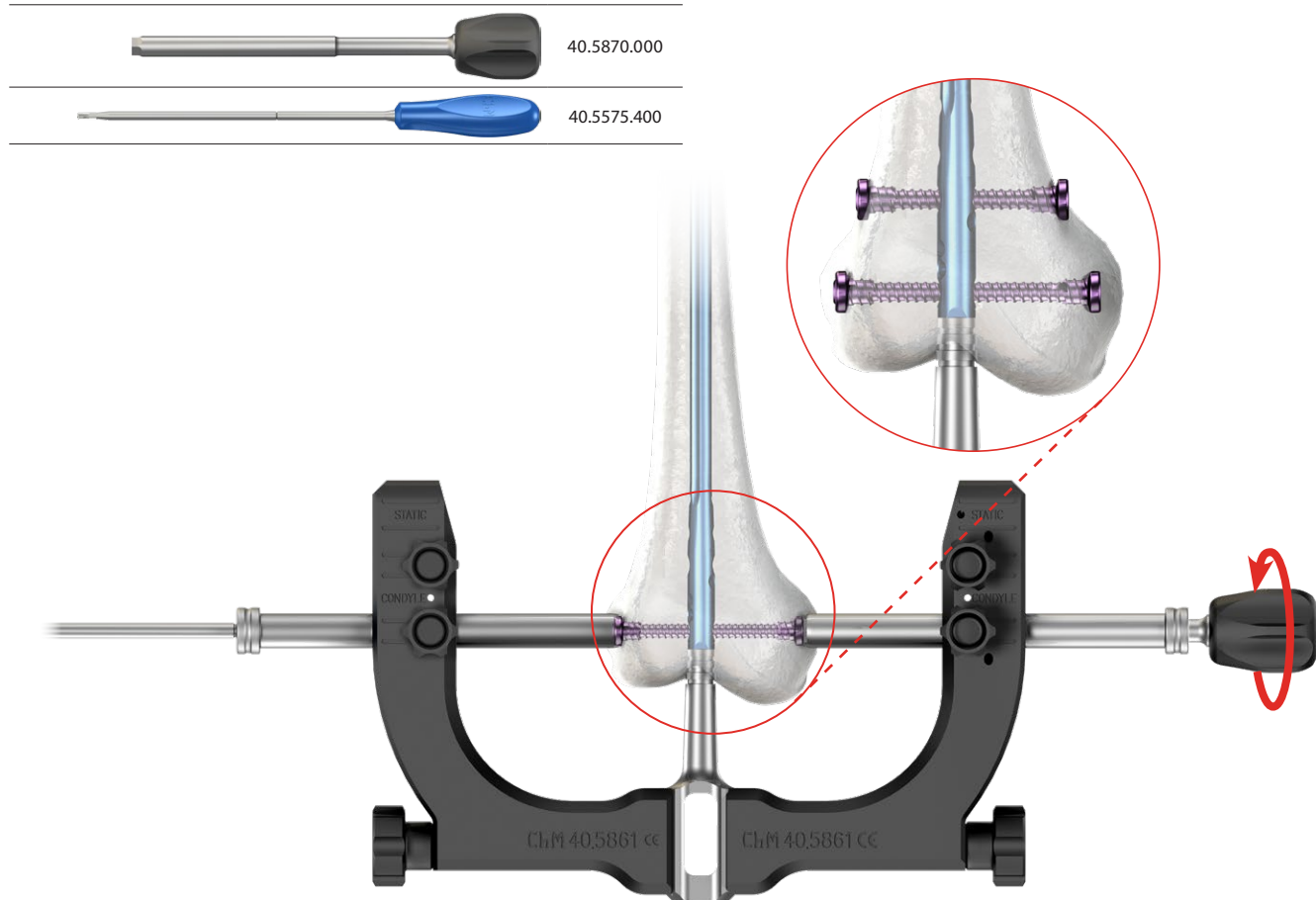

NOTE! To lock the nail in the other distal hole, repeat steps 18-21.

III.4.3. Lateral locking using 5.0 or 5.5 locking screws

- 22 Insert protective guide 9/7 [40.5510.200] and trocar 6.5 [40.5534.100] to the proximal targeter B STATIC hole.

Mark on the skin the entry point for the locking screw and perform the incision at the length of about 1.5 cm.

Insert the protective guide with trocar through the incision as close to the cortical layer as possible.

Using trocar, mark the entry point for the drill.

Remove trocar.

Leave protective guide in the hole of the targeter.

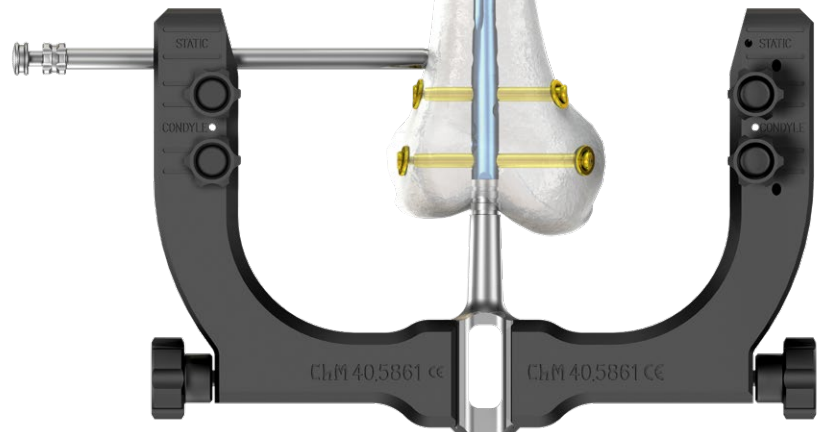
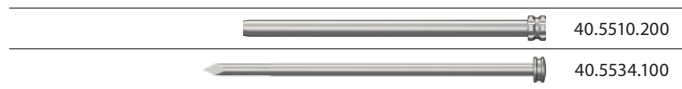

- 23 Insert drill guide 7/4 [40.6339.000] into protective guide 9/7 [40.5510.200]. Use the drive and drill with scale 4.0 [40.5347.002] to drill a hole through both cortical layers. Scale on the drill will indicate the length of the locking element.



This step should be performed under the X-Ray control with video channel.

Remove drill.

Remove drill guide.

Leave protective guide in place.

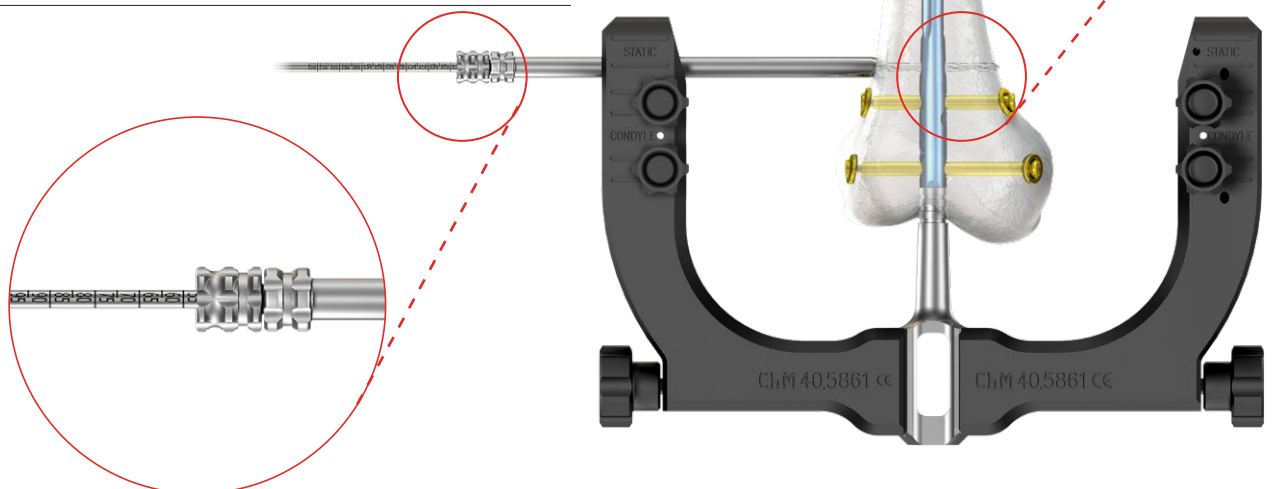

24 Using protective guide 9/7 [40.5510.200], insert screw length measure [40.5530.200] until its hook reaches the end of the hole. The tip of the guide should be in contact with the outer cortex of the femur while measuring. The B-D scale on the measure indicates the length of the locking element.

Remove screw length measure.
Leave protective guide in the hole of the targeter.

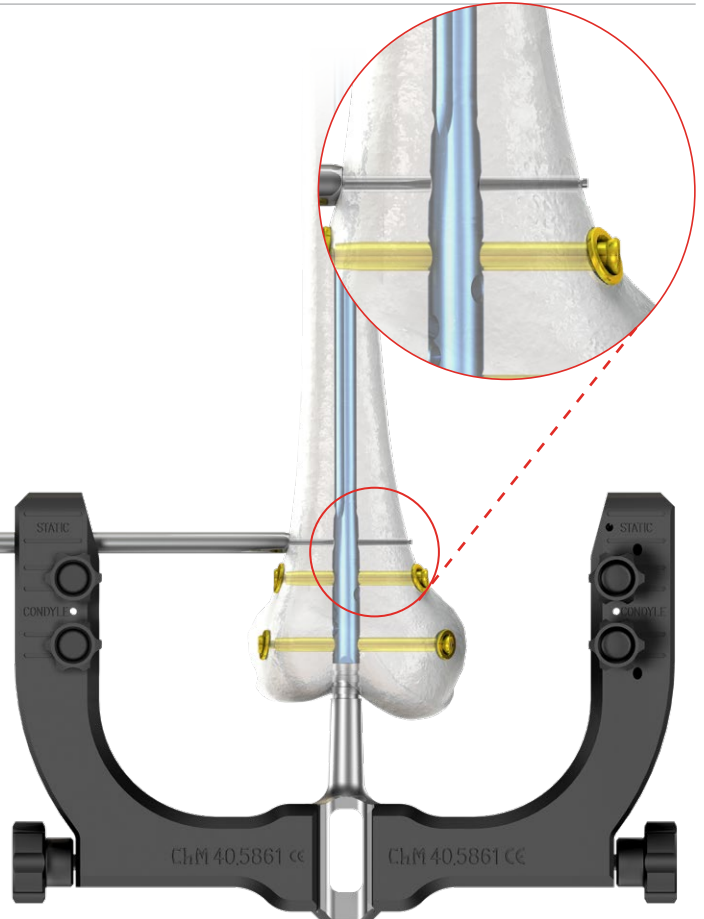
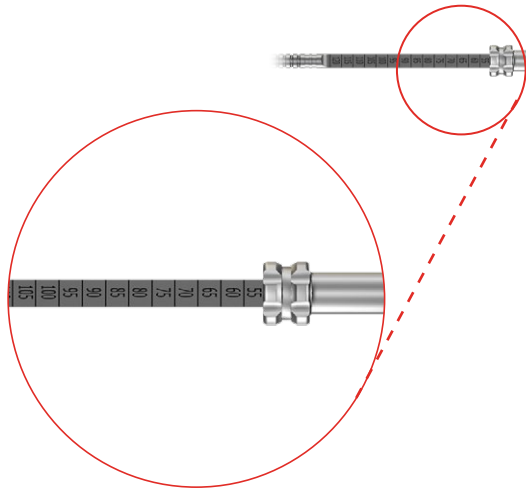
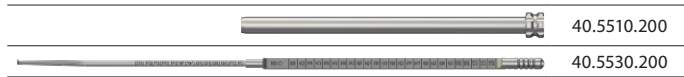



25 Insert the tip of the screwdriver T25 in the head of a chosen locking screw.

Insert the set into the protective guide and screw in the locking screw into the prepared hole in the bone, until the screw head reaches the cortex (the groove on the screwdriver shaft will align with the end of the protective guide).

Remove screwdriver.
Remove protective guide.



NOTE! To lock the nail in the other distal hole, repeat steps 22-24.

	standard locking	locking with angular stabilization
Round hole	5.0 screw (purple colour)	5.5 screw (blue colour)
		

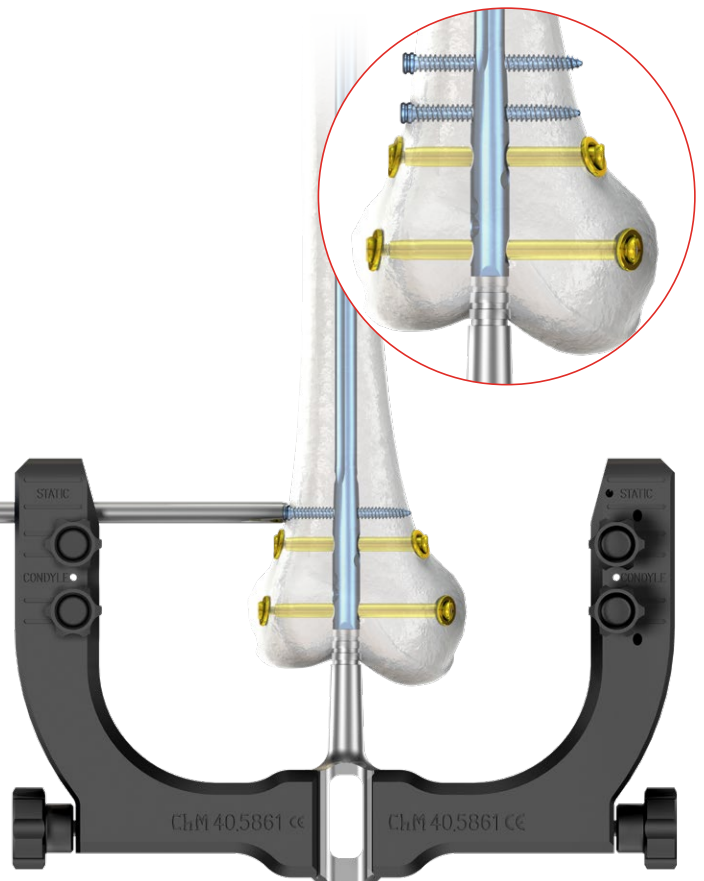

III.4.4. Oblique locking using 5.0 locking screws

- 26 Attach reconstruction targeters [40.5865] and [40.5866] to the proximal targeters B [40.5861].

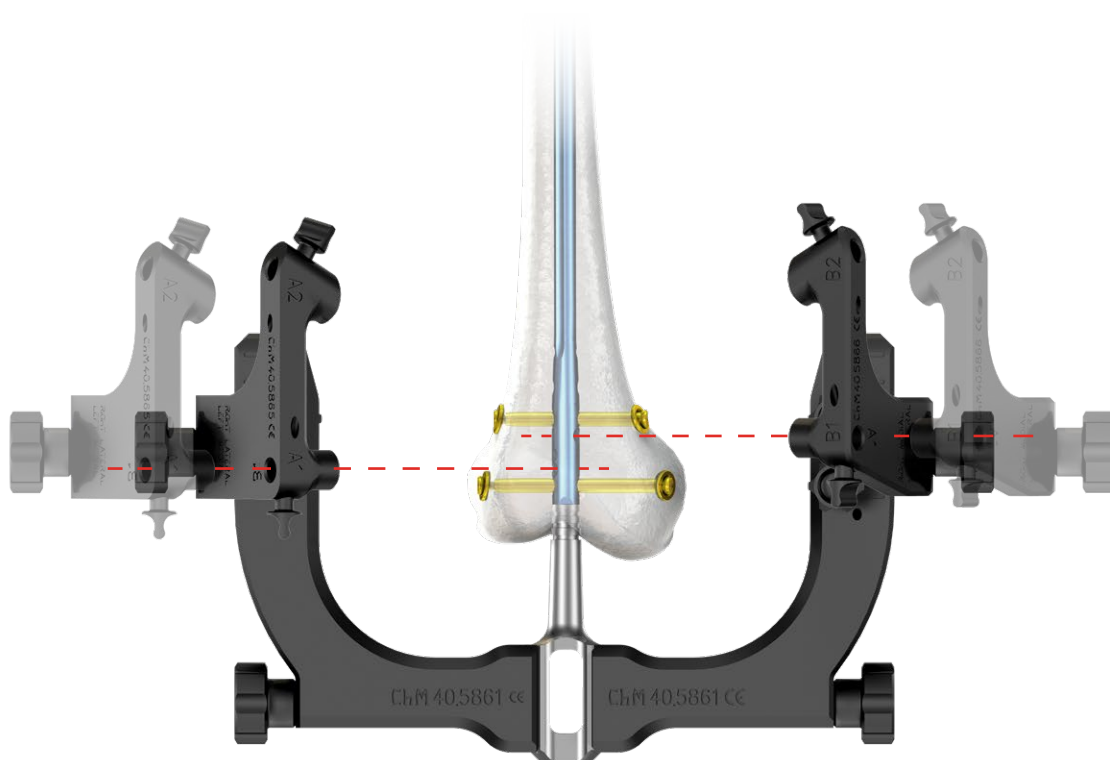

Reconstruction targeter left [40.5865]:
 - for right extremity - RIGHT LATERAL,
 - for left extremity - LEFT MEDIAL,

Reconstruction targeter right [40.5866]:
 - for right extremity - LEFT MEDIAL,
 - for left extremity - RIGHT LATERAL.

27 Insert trocar 6.5 [40.5534.100] and protective guide 9/7 [40.5510.200] in the reconstruction targeter hole. Mark on the skin the entry point for the locking screw and perform the incision at the length of about 1.5 cm. Insert the protective guide with trocar through the incision as close to the cortical layer as possible. Using trocar, mark the entry point for the drill.

Remove trocar.
Leave protective guide in the hole of the targeter.

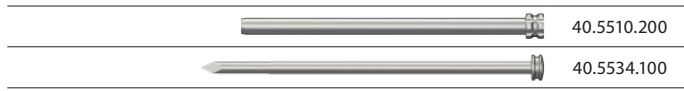

28 Insert drill guide 7/4 [40.6339.000] into protective guide 9/7 [40.5510.200]. Use the drive and drill with scale 4.0 [40.5347.002] to drill a hole through both cortical layers. Scale on the drill will indicate the length of the locking element.



This step should be performed under the X-Ray control with video channel.

Remove drill.
Remove drill guide.
Leave protective guide in place.

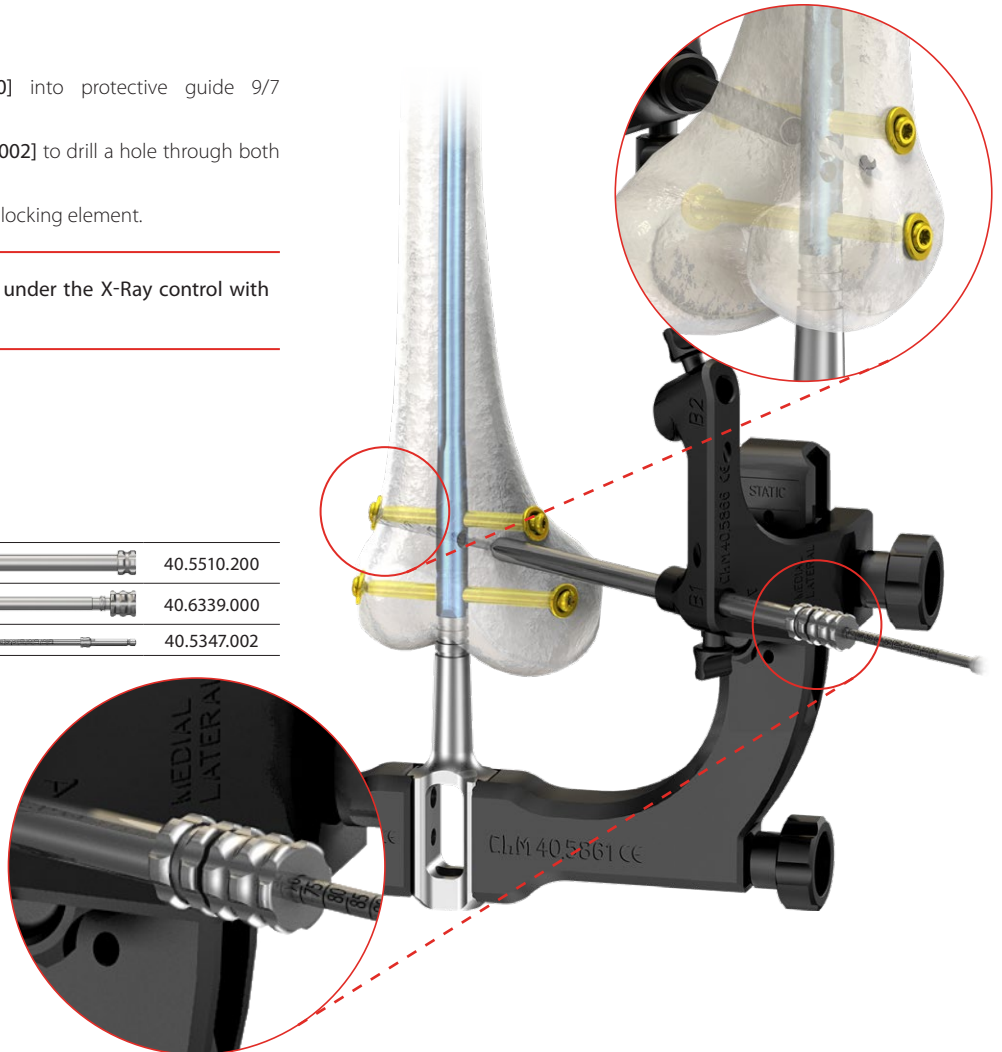

29 Using protective guide 9/7 [40.5510.200], insert screw length measure [40.5530.200] until its hook reaches the end of the hole. The tip of the guide should be in contact with the outer cortex of the femur while measuring. The B-D scale on the measure indicates the length of the locking element.

Remove screw length measure.

Leave protective guide in the hole of the targeter.



30 Insert the tip of the screwdriver T25 in the head of a chosen locking screw.

Insert the set into the protective guide and screw in the locking screw into the prepared hole in the bone, until the screw head reaches the cortex (the groove on the screwdriver shaft will align with the end of the protective guide).

Remove screwdriver.

Remove protective guide.



NOTE! To lock the nail in the other distal hole, repeat steps 23-26.

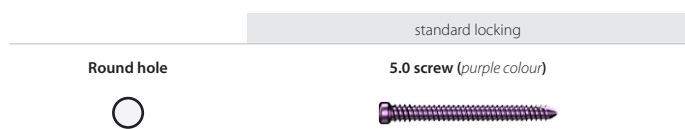

III.4.5. Condylar locking from anterosuperior approach using 5.0 locking screws

- 31 Attach reconstruction targeters [40.5865] and [40.5866] to the proximal targeters B [40.5861].



40.5861.000



40.5865.000



40.5866.000

Reconstruction targeter left [40.5865]:

- for right extremity - RIGHT LATERAL,
- for left extremity - LEFT MEDIAL,

Reconstruction targeter left [40.5866]:

- for right extremity - LEFT MEDIAL,
- for left extremity - RIGHT LATERAL.

The holes for the guides of reconstruction targeters should be located over the proximal targets.

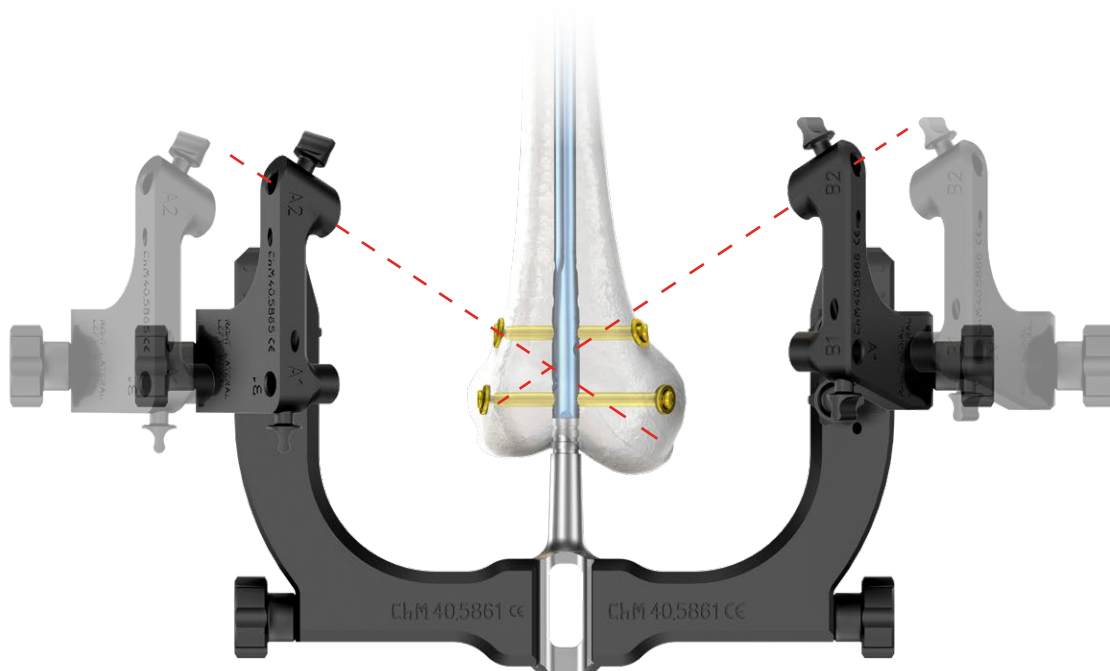

- 32 Insert trocar 6.5 [40.5534.100] and protective guide 9/7 [40.5510.200] in the reconstruction targeter hole.

Mark on the skin the entry point for the locking screw and perform the incision at the length of about 1.5 cm. Insert the protective guide with trocar through the incision as close to the cortical layer as possible. Using trocar, mark the entry point for the drill.

Remove trocar.

Leave protective guide in the hole of the targeter.

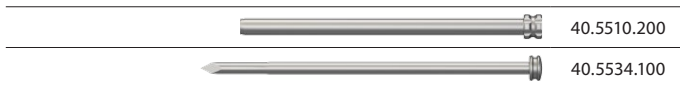

- 33 Insert drill guide 7/4 [40.6339.000] into protective guide 9/7 [40.5510.200].

Use the drive and drill with scale 4.0 [40.5347.002] to drill a hole through both cortical layers. Scale on the drill will indicate the length of the locking element.



This step should be performed under the X-Ray control with video channel.

Remove drill.

Remove drill guide.

Leave protective guide in place.

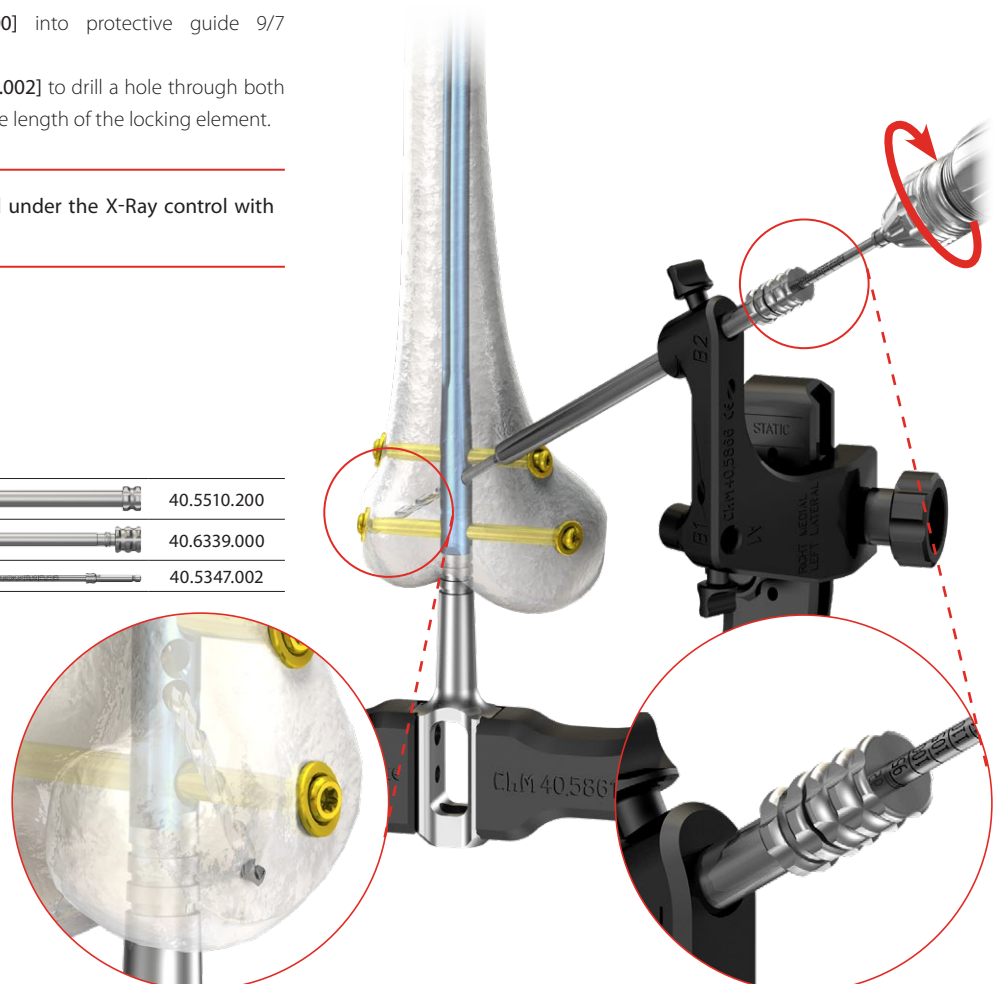

- 34 Using protective guide 9/7 [40.5510.200], insert screw length measure [40.5530.200] until its hook reaches the end of the hole.

The tip of the guide should be in contact with the outer cortex of the femur while measuring.

The B-D scale on the measure indicates the length of the locking element.

Remove screw length measure.

Leave protective guide in the hole of the targeter.

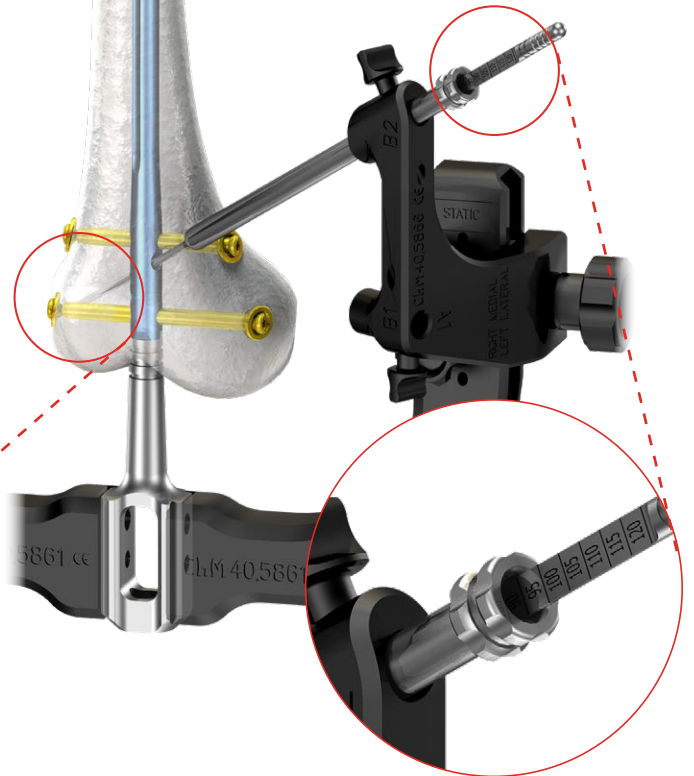
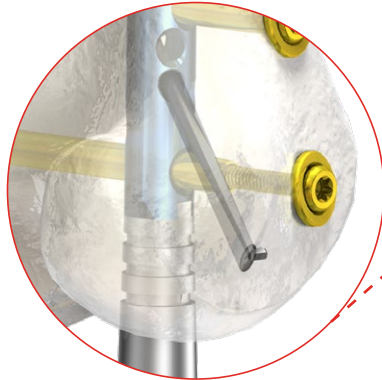
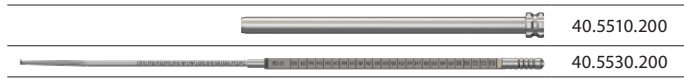

- 35 Insert the tip of the screwdriver T25 in the head of a chosen locking screw. Insert the set into the protective guide and screw in the locking screw into the prepared hole in the bone, until the screw head reaches the cortex (the groove on the screwdriver shaft will align with the end of the protective guide).

Remove screwdriver.

Remove protective guide.



NOTE! To lock the nail in the other distal hole, repeat steps 28-31.

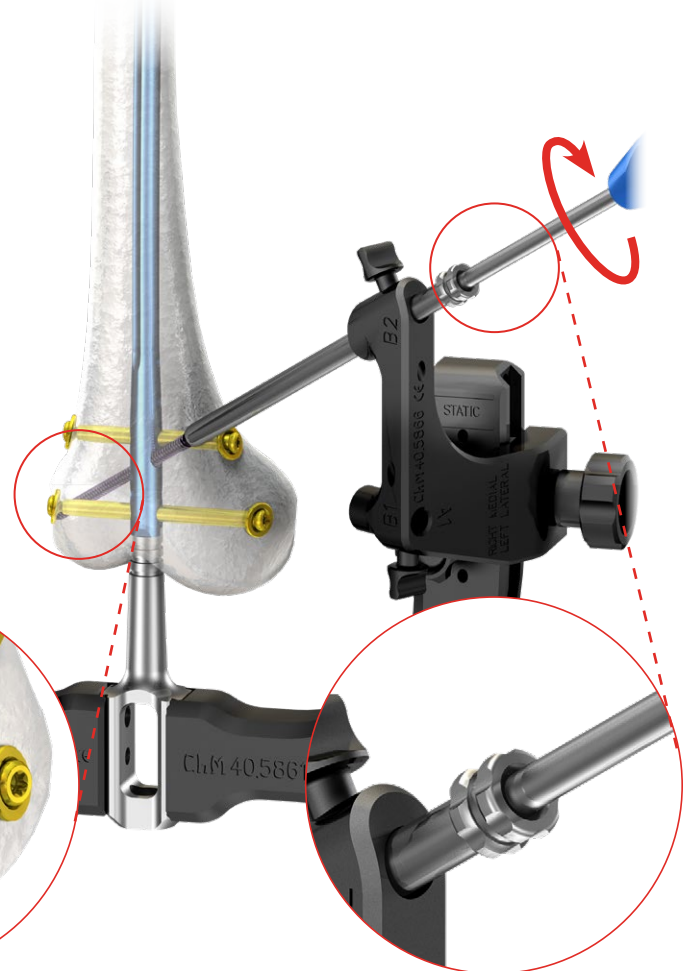
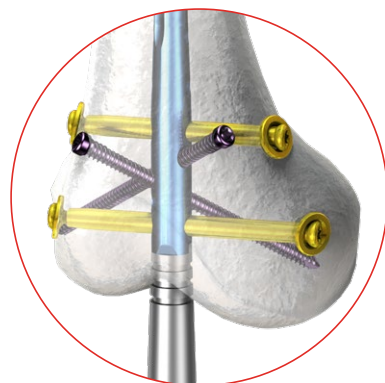

III.4.6. Condylar locking from condyle using 5.0 locking screw

- 36 Attach reconstruction targeters [40.5865] and [40.5866] to the proximal targeters B [40.5861].



Reconstruction targeter left [40.5865]:

- for right extremity - RIGHT LATERAL,
- for left extremity - LEFT MEDIAL,

Reconstruction targeter right [40.5866]:

- for right extremity - LEFT MEDIAL,
- for left extremity - RIGHT LATERAL.

The holes for the guides of reconstruction targeters should be located under the proximal targeters.

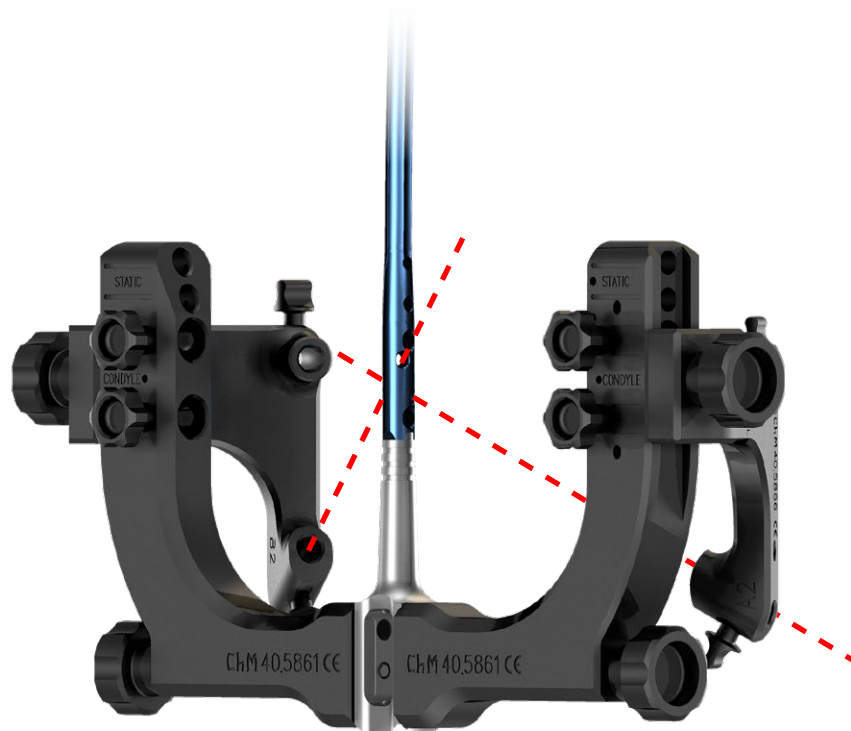

- 37 Insert trocar 6.5 [40.5534.100] and protective guide 9/7 [40.5510.200] in the reconstruction targeter hole.

Mark on the skin the entry point for the locking screw and perform the incision at the length of about 1.5 cm.

Insert the protective guide with trocar through the incision as close to the cortical layer as possible. Using trocar, mark the entry point for the drill.

Remove trocar.

Leave protective guide in the hole of the targeter.

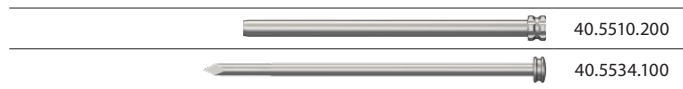

- 38 Insert drill guide 7/4 [40.6339.000] into protective guide 9/7 [40.5510.200].

Use the drive and drill with scale 4.0 [40.5347.002] to drill a hole through both cortical layers. Scale on the drill will indicate the length of the locking element.



This step should be performed under the X-Ray control with video channel.

Remove drill.

Remove drill guide.

Leave protective guide in place.

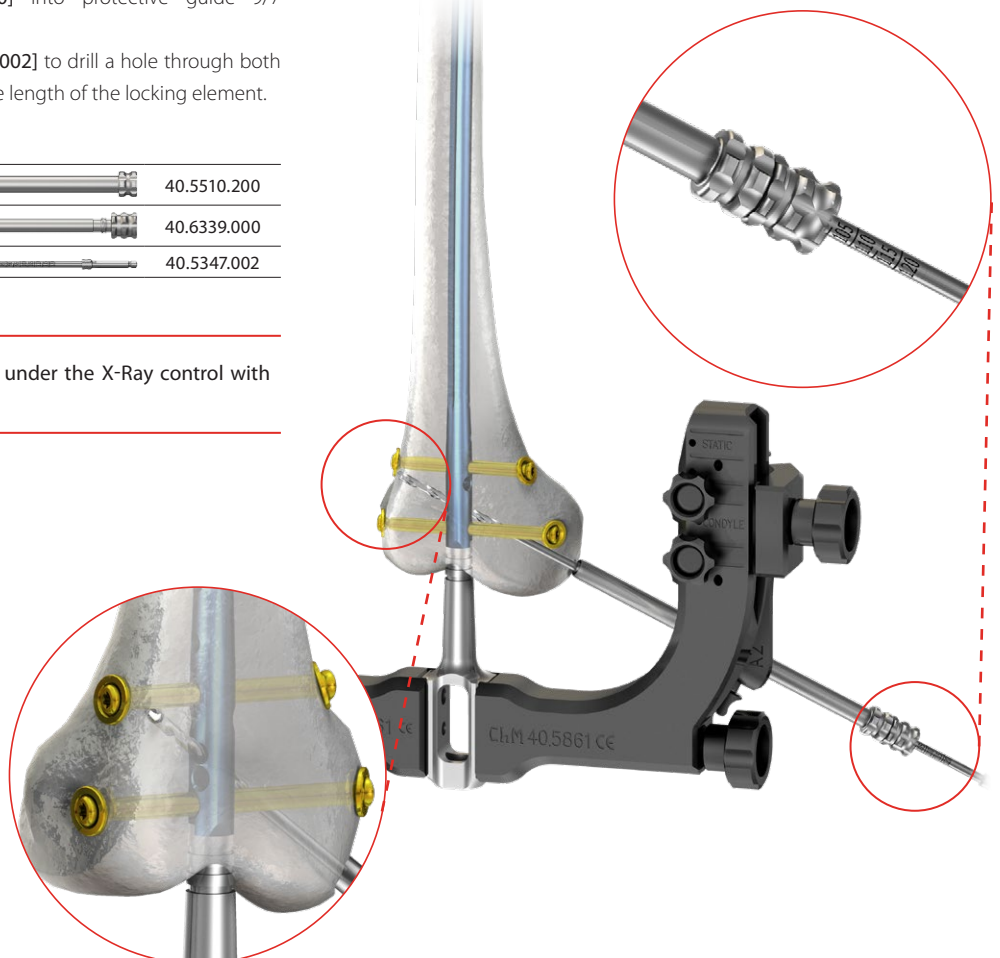

39 Using protective guide 9/7 [40.5510.200], insert screw length measure [40.5530.200] until its hook reaches the end of the hole.

The tip of the guide should be in contact with the outer cortex of the femur while measuring. The B-D scale on the measure indicates the length of the locking element.

Remove screw length measure.

Leave protective guide in the hole of the targeter.

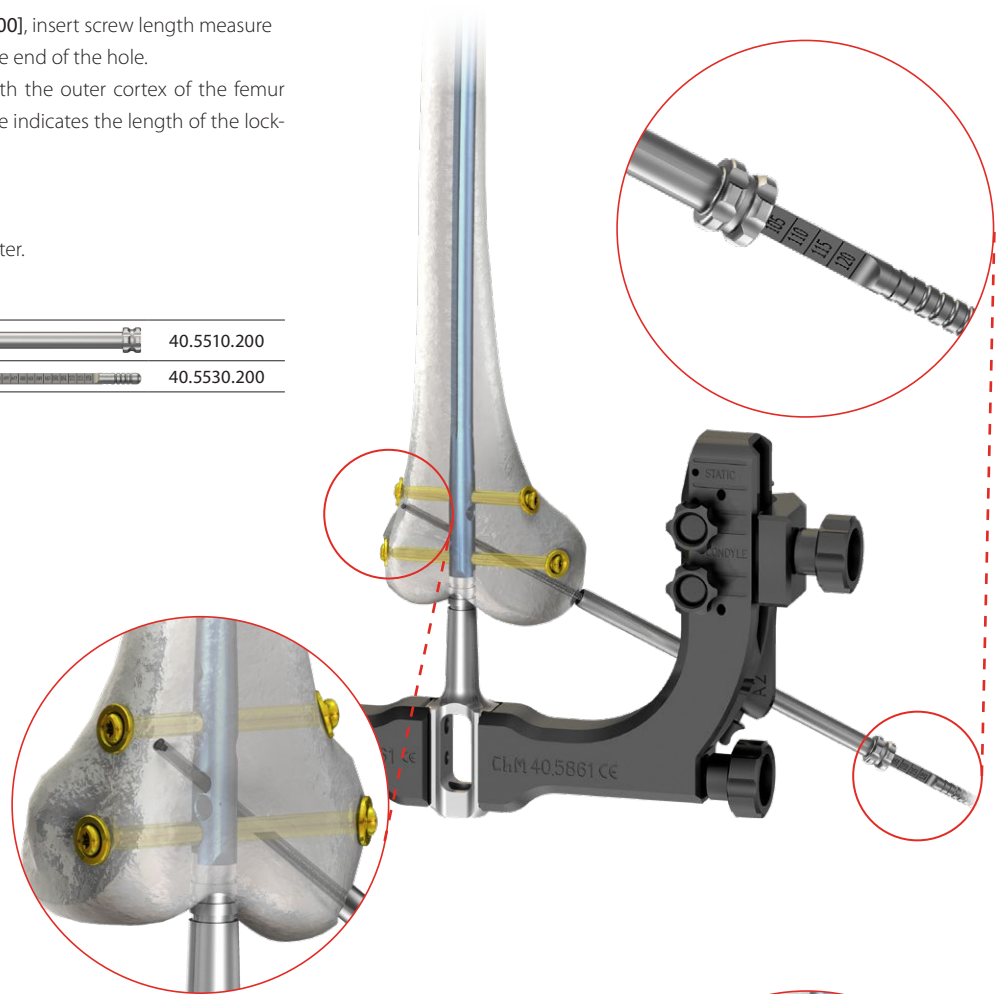
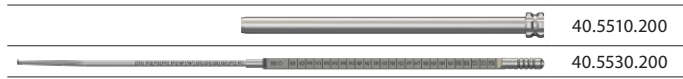

40 Insert the tip of the screwdriver T25 in the head of a chosen locking screw.

Insert the set into the protective guide and screw in the locking screw into the prepared hole in the bone, until the screw head reaches the cortex (the groove on the screwdriver shaft will align with the end of the protective guide).

Remove screwdriver.

Remove protective guide.

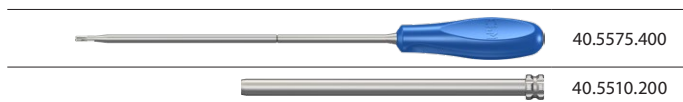

NOTE! To lock the nail in the other distal hole, repeat steps 37-40.

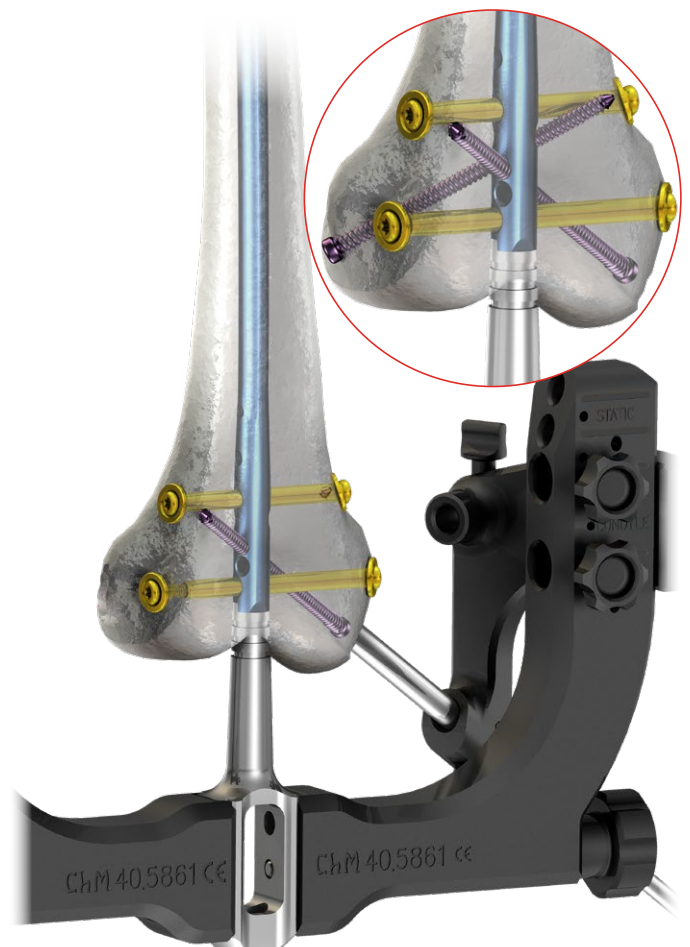

III.5. NAIL LOCKING IN THE SHAFT OF THE FEMUR

- 41 Attach targeter D [40.5863] to the proximal targeter B [40.5861].

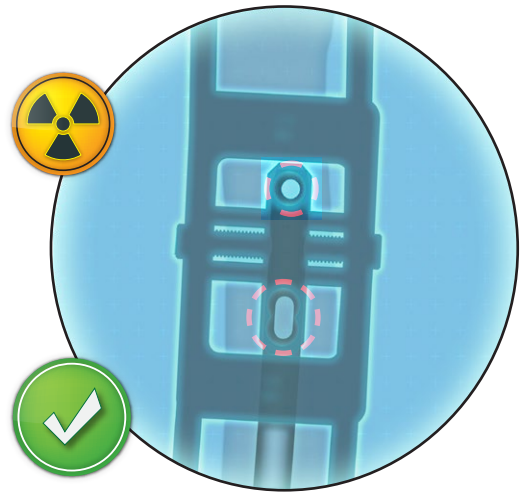

Verify under the X-Ray control the location of the holes in the targeter D slider and holes in the nail.



The holes in the nail and drill guide must overlap – on the screen there must be a round shape presented (*images resembling a circle are permissible*).



If the image from X-Ray video channel is different than a circle, adjust the targeter. To do this, move the adjustable slider of the targeter (*by turning the handwheel left or right*) until the round shape on the screen appears (*images resembling a circle are permissible*).

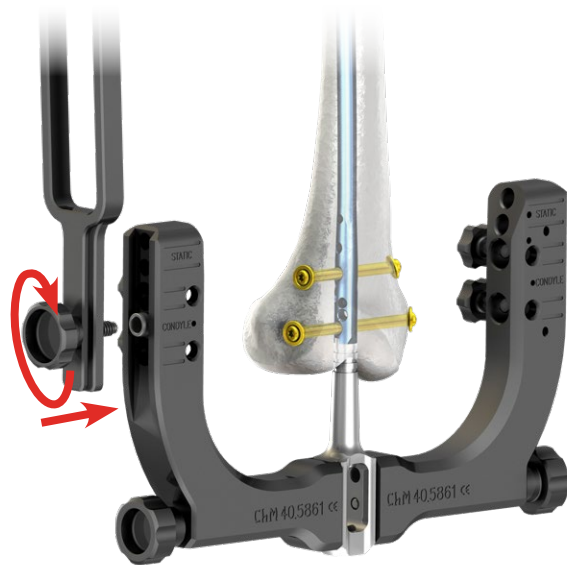

- 42 The nail may be locked in its distal part at three levels maximally.

Targeter D [40.5863] is used for lateral locking:

- 1 round hole,
- 1 oval shaped hole.

Depending on the fracture stabilization method, it is possible to insert locking screws in the nail oval shaped hole:

a. static method: instruments of instrument set [40.5860.500] shall be inserted in the distal part of the double hole.

b. dynamic method with compression: instruments of instrument set [40.5860.500] shall be inserted in the proximal part of the double hole.

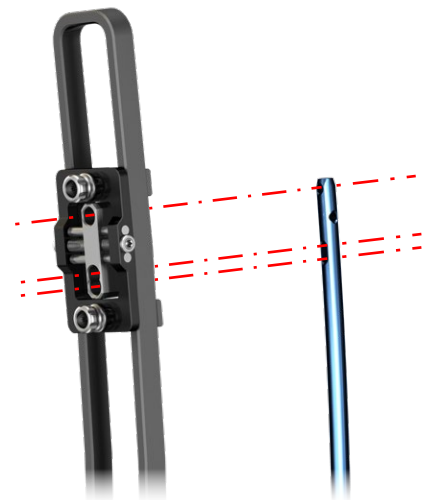

- 43 Insert trocar 6.5 [40.5534.100] and protective guide 9/7 [40.5510.200] in the chosen targeter D slider hole.

Mark on the skin the entry point for the locking screw and perform the incision at the length of about 1.5 cm.

Insert the protective guide with trocar through the incision as close to the cortical layer as possible. Using trocar, mark the entry point for the drill.

Remove trocar.

Leave protective guide in the hole of the targeter.

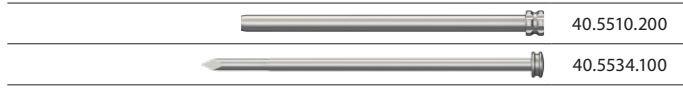

- 44 Insert drill guide 7/4 [40.6339.000] into protective guide 9/7 [40.5510.200].

Use the drive and drill with scale 4.0 [40.5347.002] to drill a hole through both cortical layers.

Scale on the drill will indicate the length of the locking element. Leave the drill in the bone.



This step should be performed under the X-Ray control with video channel.



- 45 Insert trocar 6.5 [40.5534.100] and protective guide 9/7 [40.5510.200] in the other targeter D slider hole.

Mark on the skin the entry point for the locking screw and perform the incision at the length of about 1.5 cm.

Insert the protective guide with trocar through the incision as close to the cortical layer as possible.

Using trocar, mark the entry point for the drill.

Remove trocar.

Leave protective guide in the hole of the targeter.

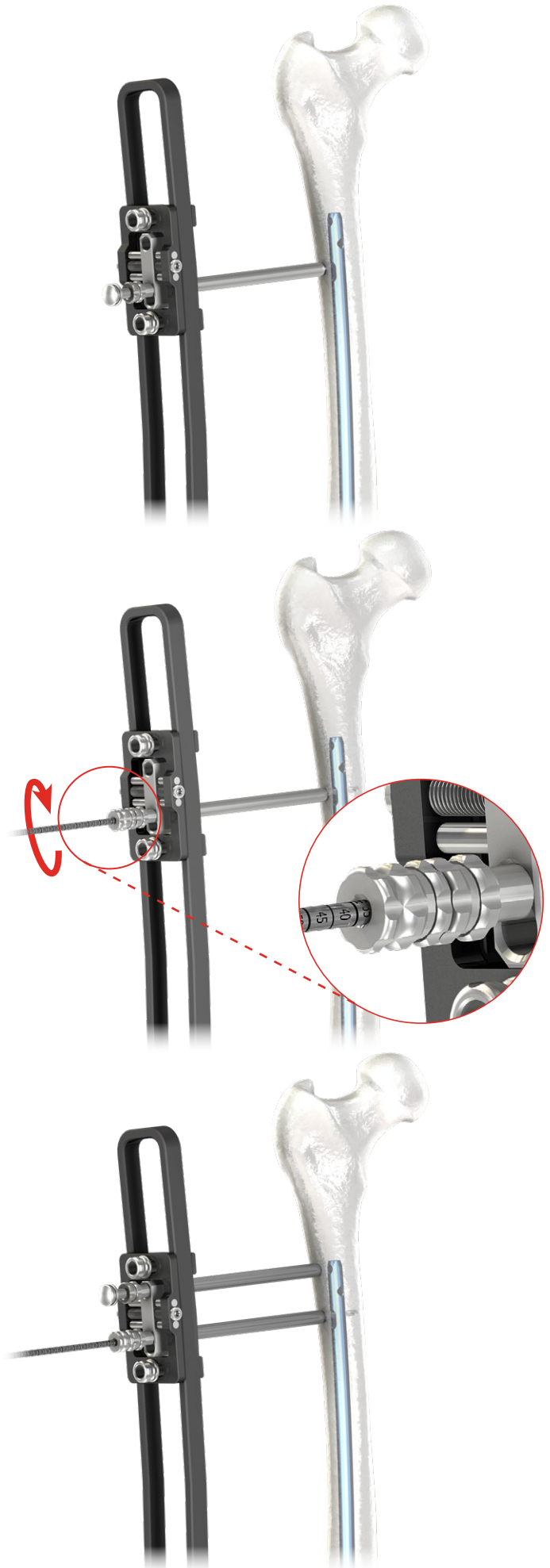
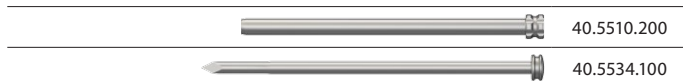

- 46 Insert drill guide 7/4 [40.6339.000] into protective guide 9/7 [40.5510.200].

Use the drive and drill with scale 4.0 [40.5347.002] to drill a hole through both cortical layers.
Scale on the drill will indicate the length of the locking element.

Remove drill.
Remove drill guide.
Leave protective guide in place.

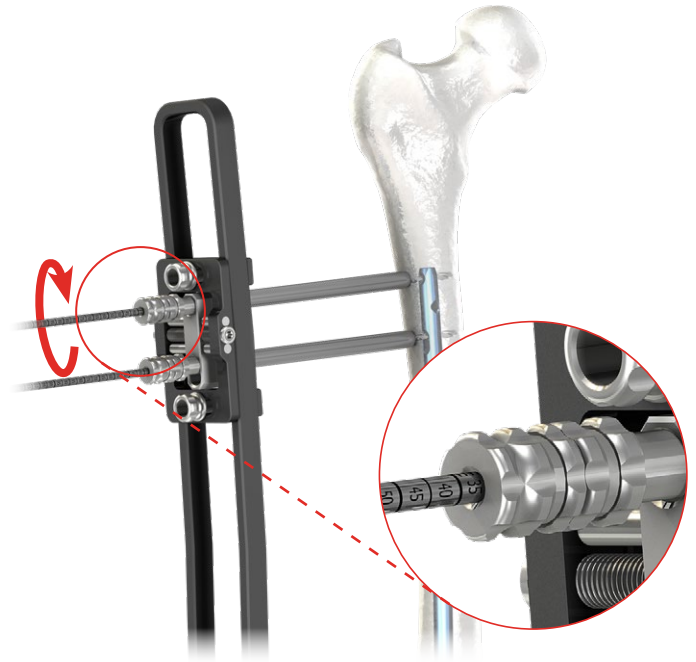

- 47 Using protective guide 9/7 [40.5510.200], insert screw length measure [40.5530.200] until its hook reaches the end of the hole.

The tip of the guide should be in contact with the outer cortex of the femur while measuring.
The B-D scale on the measure indicates the length of the locking element.

Remove screw length measure.
Leave protective guide in the hole of the targeter.

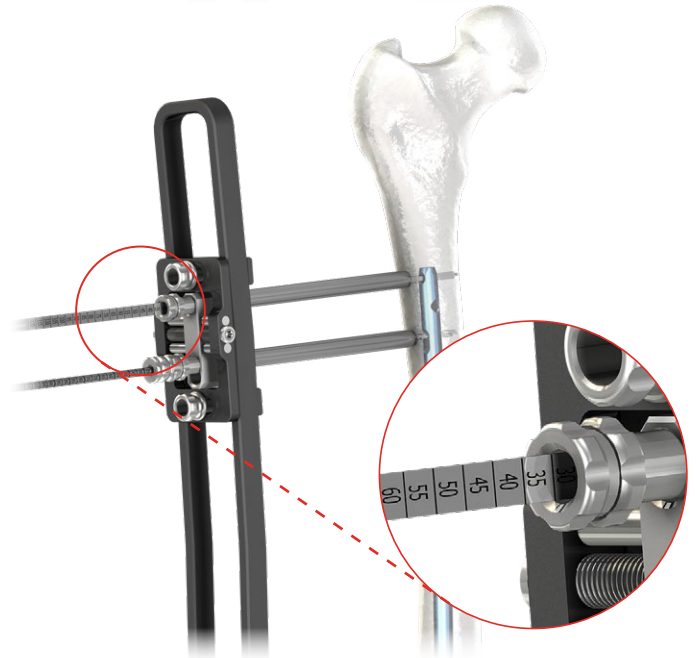
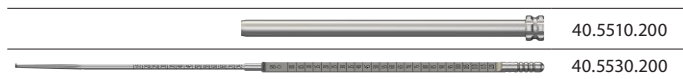

- 48 Insert the tip of the screwdriver T25 in the head of a chosen locking screw.

Insert the set into the protective guide and screw in the locking screw into the prepared hole in the bone, until the screw head reaches the cortex (*the groove on the screwdriver shaft will align with the end of the protective guide*).

Remove screwdriver.

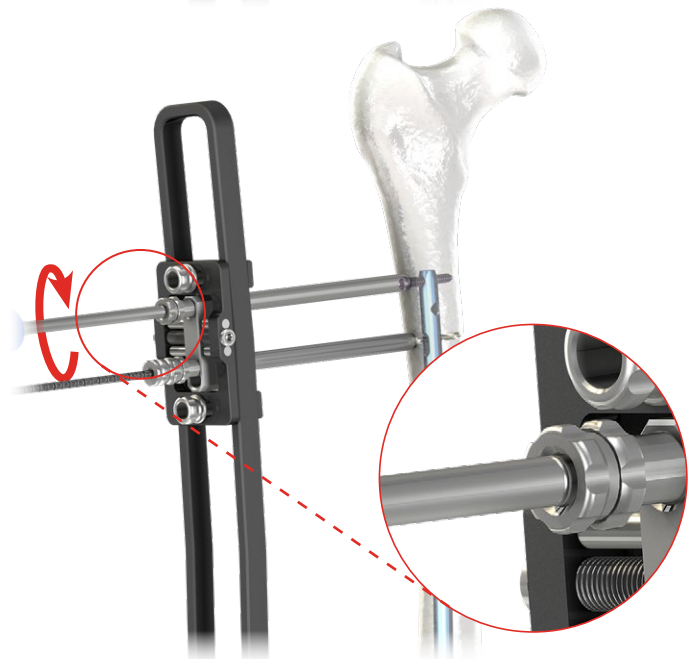

49 Remove the drill and drill guide from the first hole. Leave protective guide in the hole of the targeter.

Using protective guide 9/7 [40.5510.200], insert screw length measure [40.5530.200] until its hook reaches the end of the hole.

The tip of the guide should be in contact with the outer cortex of the femur while measuring.

The B-D scale on the measure indicates the length of the locking element.

Remove screw length measure.

Leave protective guide in the hole of the targeter.

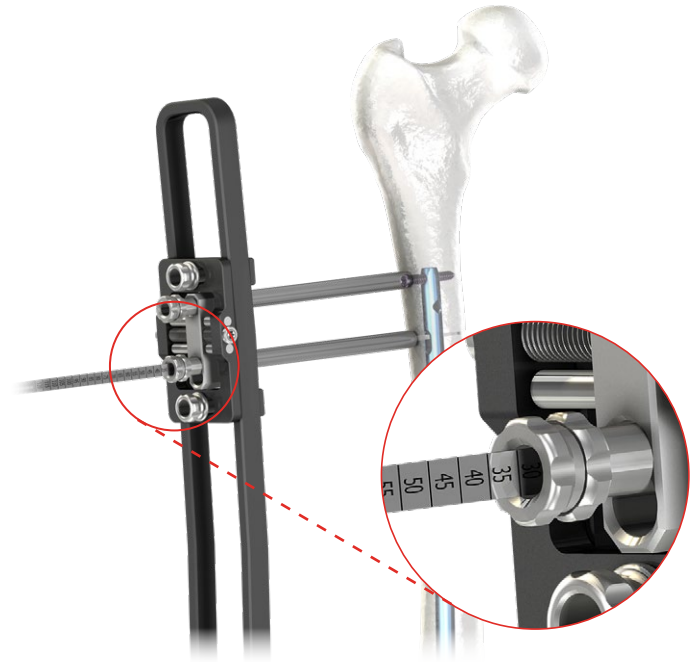

50 Insert the tip of the screwdriver T25 in the head of a chosen locking screw.

Insert the set into the protective guide and screw in the locking screw into the prepared hole in the bone, until the screw head reaches the cortex (*the groove on the screwdriver shaft will align with the end of the protective guide*).

Remove screwdriver.

Remove protective guide.

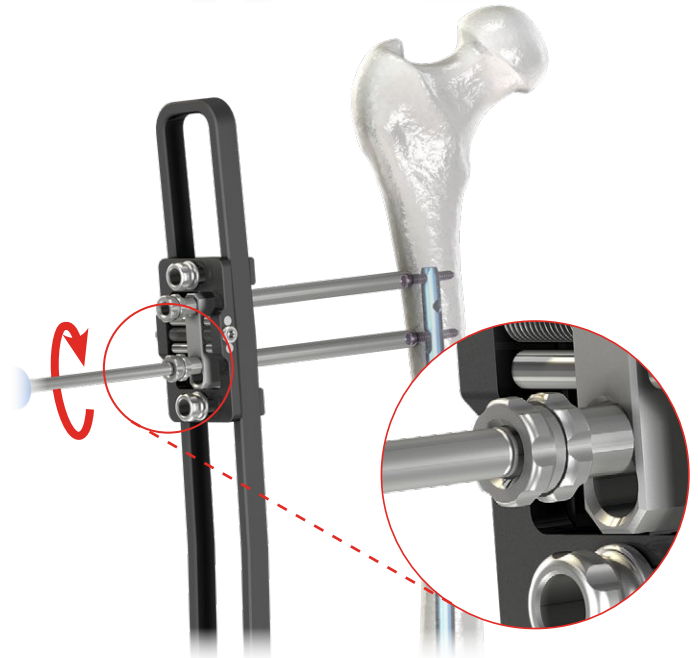
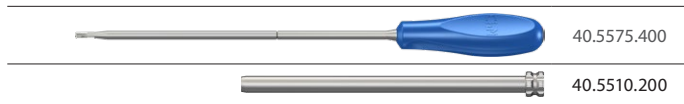

	standard locking	locking with angular stabilization
Round hole 	5.0 screw (purple colour) 	5.5 screw (blue colour)
Oval shaped hole 	5.0 screw (purple colour) 	

III.6. LOCKING THE NAIL USING 'FREE HAND' TECHNIQUE - METHOD I



This step should be performed under the X-Ray control with video channel.

- 51 While drilling, it is recommended to use an angular drill attachment, so that the operator's hands are outside the direct exposure to X-Rays.

Mark on the skin the entry point for the locking screw and perform the incision at the length of about 1.5 cm.

52



Using the X-Ray imaging, determine the location of the protective guide short [40.5871.100] in relation to the hole in the intramedullary nail.

The holes in the nail and protective guide short [40.5871.100] shall overlap.

The sharp edge of the guide should be immersed in the cortical bone. Insert short trocar 7 [40.1354.100] into protective guide short and lead it to the cortex where the entry point for a drill shall be marked.

Remove short trocar 7.

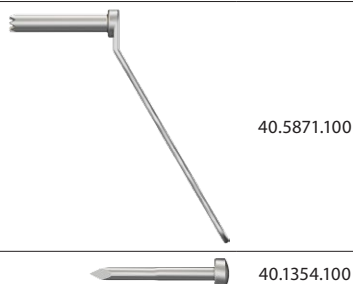

- 53 Insert drill guide short 7/4.0 [40.6365.000] into protective guide short [40.5871.100].

Use the drive and drill with scale 4.0/150 [40.5348.002] to drill a hole through both cortical layers. Scale on the drill will indicate the length of the locking element.

Remove drill.

Remove drill guide.

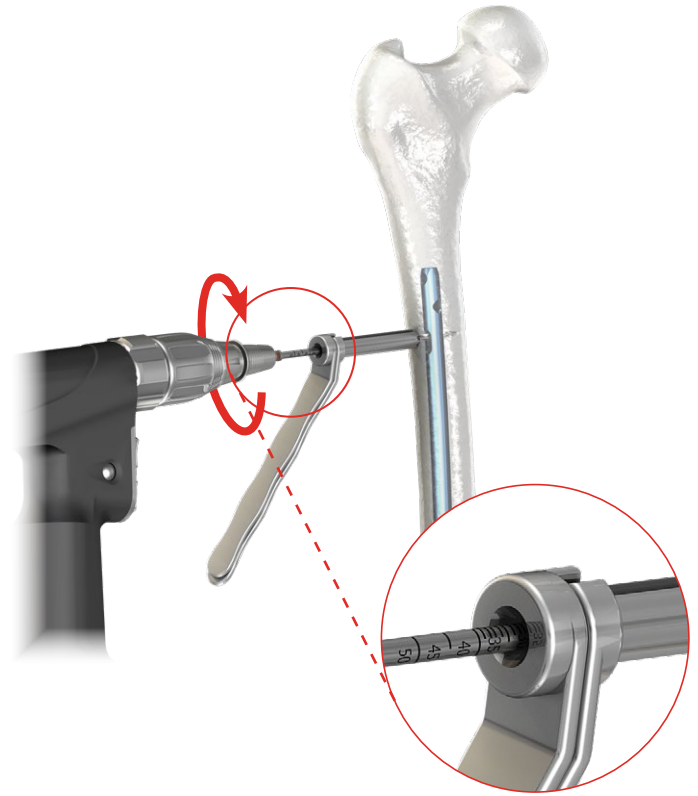
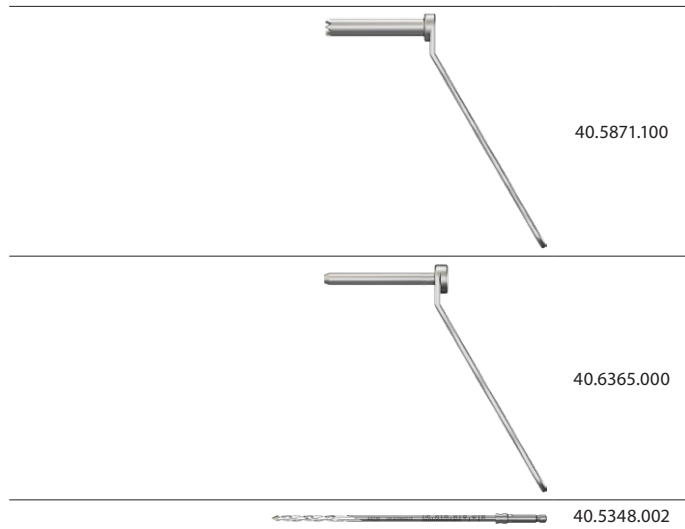

- 54 Using protective guide short [40.5871.100], insert screw length measure [40.5530.200] until its hook reaches the outer layer of the second cortical bone. The D scale on the measure indicates the length of the locking element.

Remove screw length measure.

Leave protective guide in place.

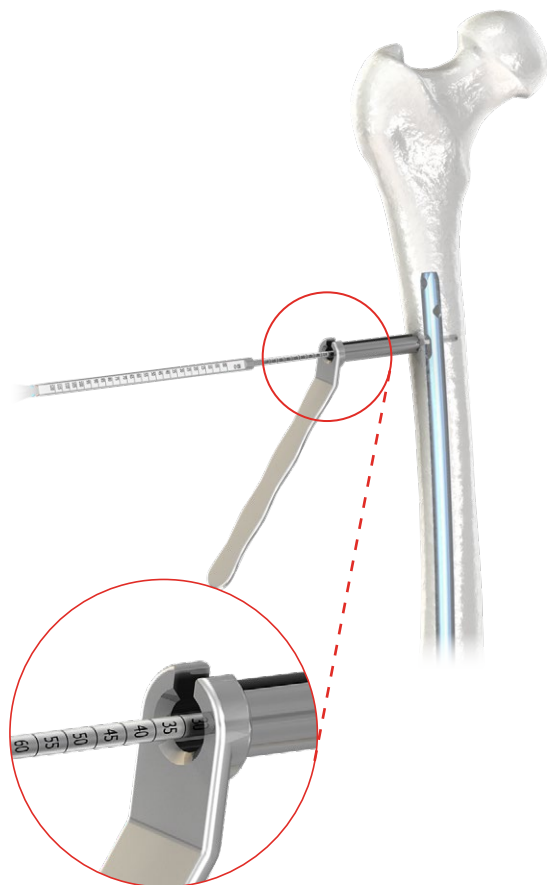
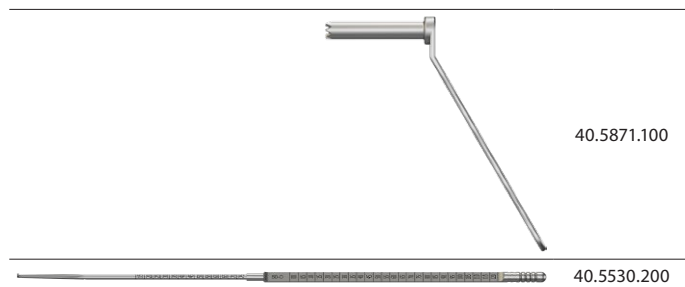



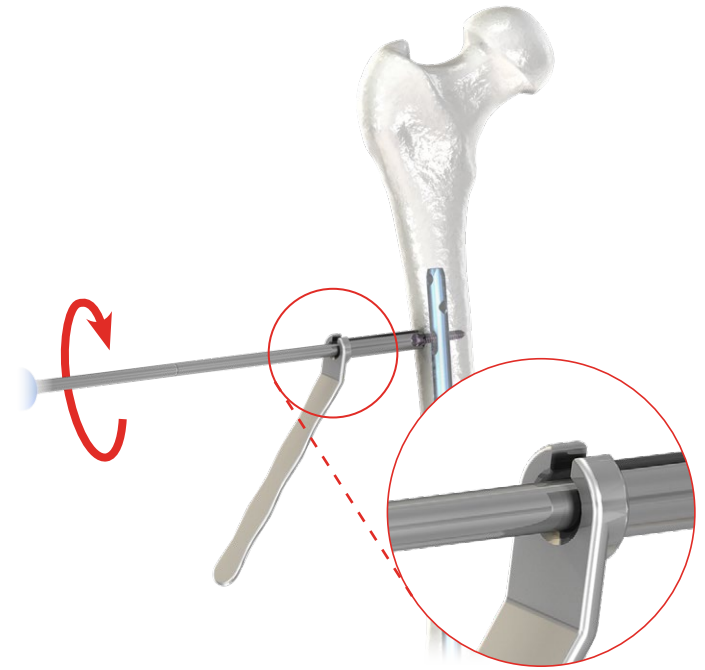
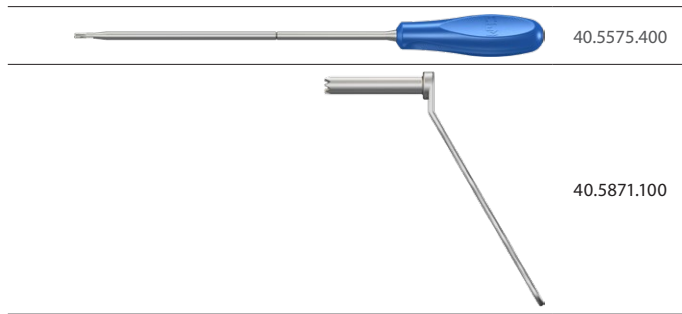

55 Insert the tip of the screwdriver T25 in the head of a chosen locking screw.

Insert the set into the protective guide short [40.5871.100] and screw in the locking screw into the prepared hole in the bone, until the screw head reaches the cortex.

Remove screwdriver.
Remove protective guide.



	standard locking	locking with angular stabilization
Round hole 	5.0 screw (purple colour) 	5.5 screw (blue colour) 
Oval shaped hole 	5.0 screw (purple colour) 	

III.7. LOCKING THE NAIL USING 'FREE HAND' TECHNIQUE - METHOD II



Use current radiological examination to determine the drilling location and to control the drilling process.

56 Set the X-Ray apparatus in such a way that the nail hole on the screen is of a circular shape. Place the tip of drill with scale 4.0/150 [40.5348.002] in the middle of the nail hole visible on the screen. Mark on the skin the entry points for the drill and perform the incision at the length of about 1.5 cm.



57 Again, place the tip of drill with scale 4.0/150 [40.5348.002] in the middle of the nail hole. Lean the tip of the drill against the bone and turn so that the drilling direction is consistent with the nail hole.

Insert protective guide short [40.5871.100] on drill to protect soft tissues.

Use the drive and drill with scale 4.0/150 [40.5348.002] to drill a hole through both cortical layers.

Remove drill.



58 Using protective guide short [40.5871.100], insert screw length measure [40.5530.200] until its hook reaches the outer layer of the second cortical bone. The D scale on the measure indicates the length of the locking element.

Remove screw length measure.
Leave protective guide in place.

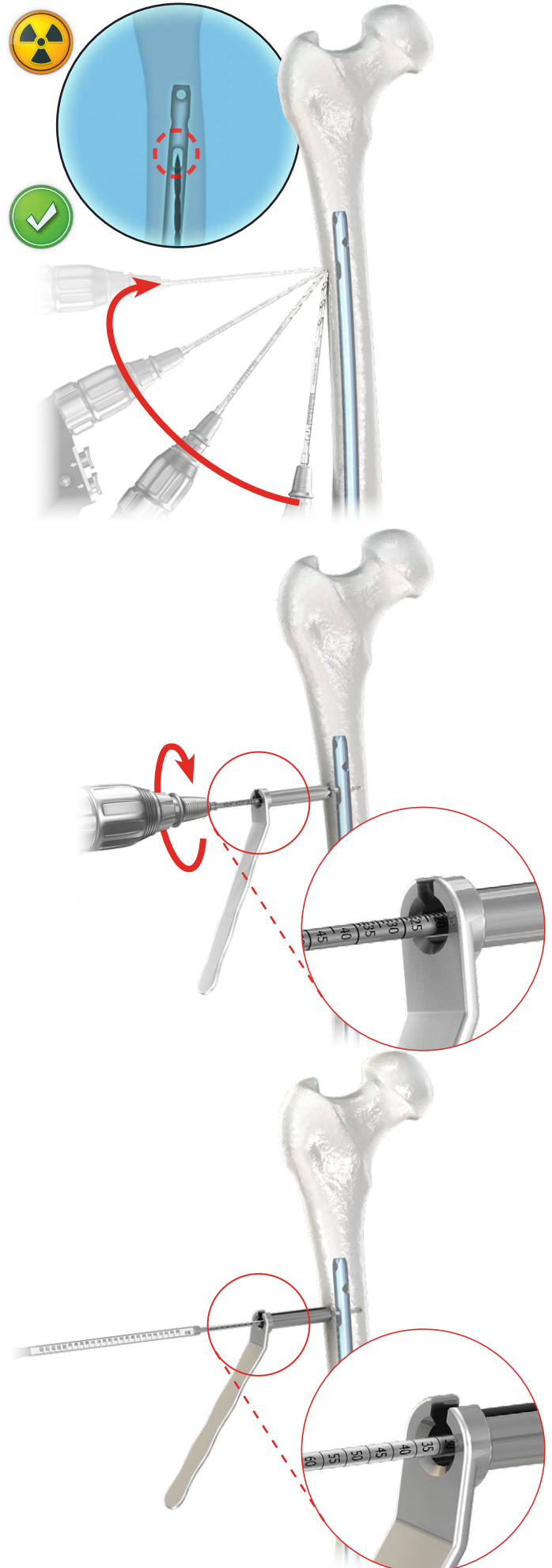
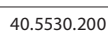





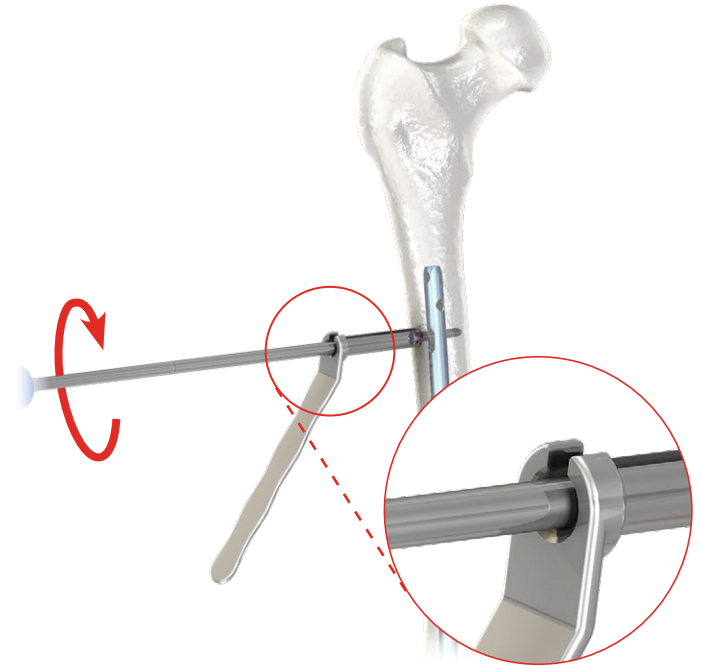
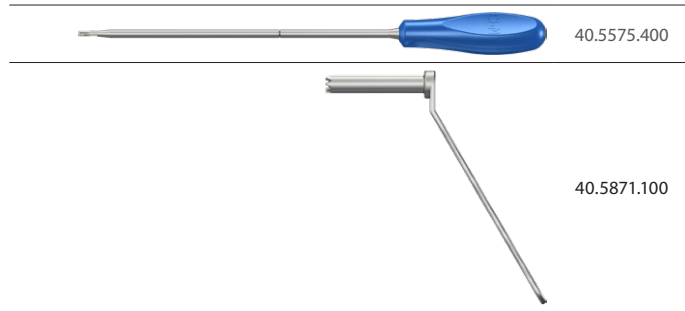

59 Insert the tip of the screwdriver T25 in the head of a chosen locking screw.

Insert the set into the protective guide short [40.5871.100] and screw in the locking screw into the prepared hole in the bone, until the screw head reaches the cortex.

Remove screwdriver.

Remove protective guide.



	standard locking	locking with angular stabilization
Round hole 	5.0 screw (purple colour) 	5.5 screw (blue colour) 
Oval shaped hole 	5.0 screw (purple colour) 	

III.8. END CAP INSERTION

- 60 When the fixation is done, remove the targeter from the nail using wrench S8 [40.5304.200].

In order to protect the internal thread of the nail against bone ingrowth, insert the end cap [3.5161.006] (implant) using screwdriver T25 [40.5575.400] to the threaded hole in the nail shaft.

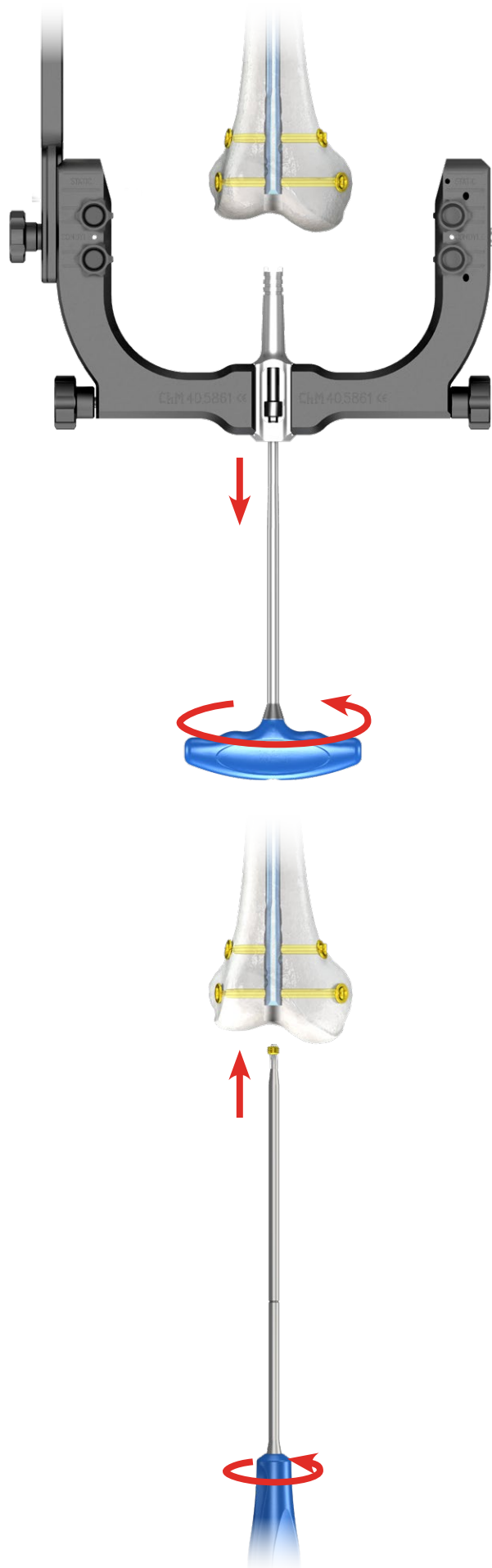

III.9. NAIL REMOVAL

- 61 Remove end cap [3.5161.006] (implant) using screwdriver T25 [40.5575.400] from the nail shaft.



- 62 Use the screwdriver T25 [40.5575.400] to remove all the locking screws from the distal and proximal parts of the nail and wrench for nuts [40.5870.000] to remove the nuts from the proximal part of the nail, if they were used.

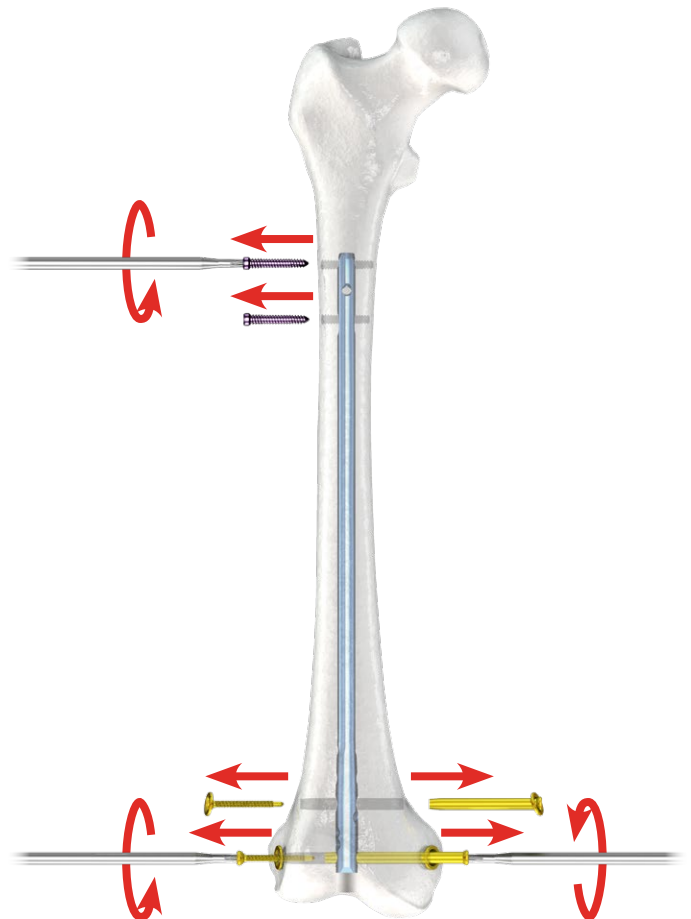

63 Insert connector M8x1.25/M14 [40.5873] in the threaded hole of the nail shaft.

Attach impactor-extractor [40.5308].

Remove the nail from the intramedullary canal using mallet [40.3667].

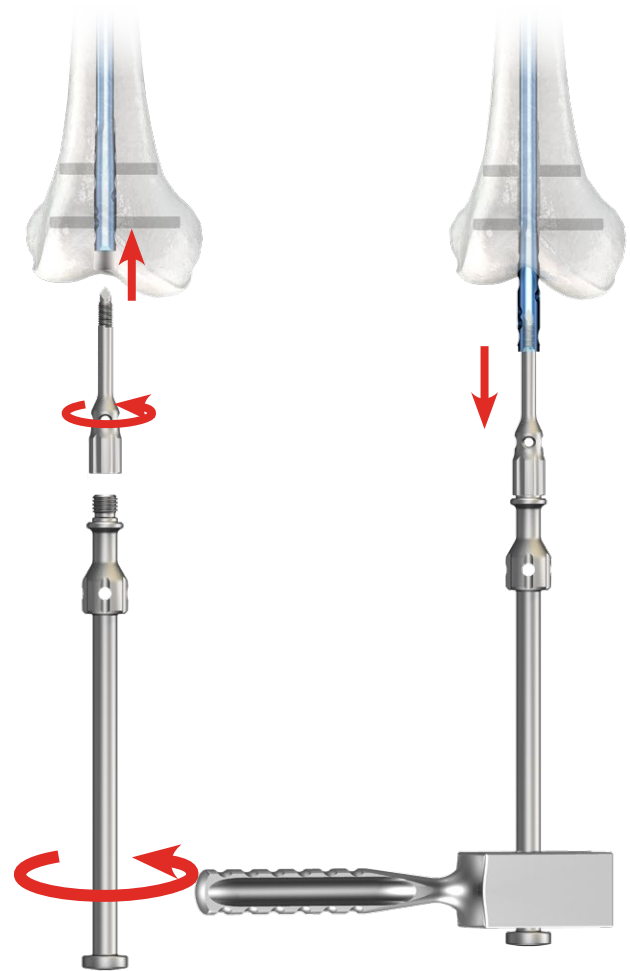
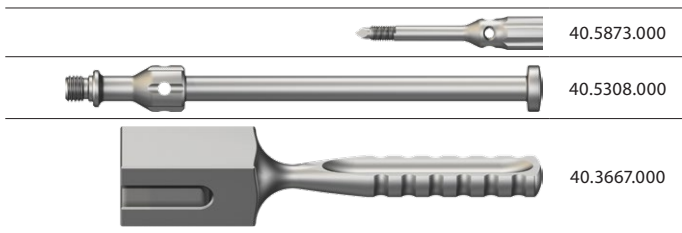

ChM sp. z o.o.

Lewickie 3b
16-061 Juchnowiec Kościelny
Poland

tel. +48 85 86 86 100

fax +48 85 86 86 101

chm@chm.eu

www.chm.eu



CE 0197