

CHM<sup>®</sup>

CHARSPINE *system*

## ALIF PEEK INTERVERTEBRAL CAGES

- *IMPLANTS*
- *INSTRUMENT SET 40.6241.000*
- *SURGICAL TECHNIQUE*

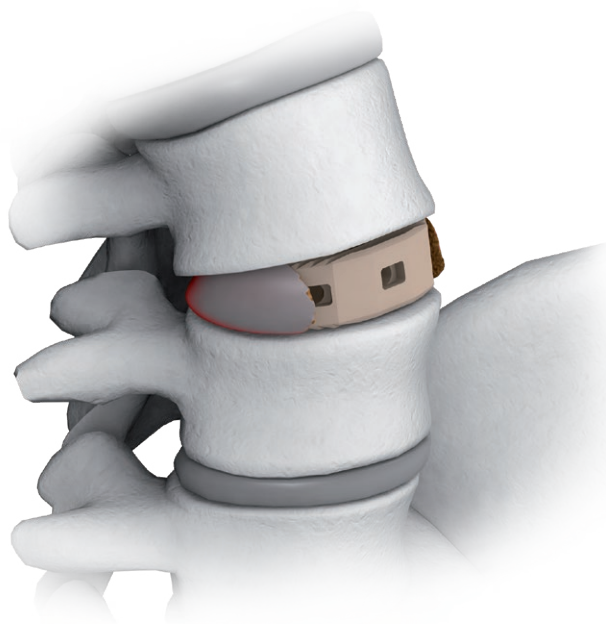

## SYMBOLS DESCRIPTION



Caution - pay attention to a special procedure.



Perform the activity under X-Ray control.



Information about the next stages of a procedure.



Proceed to the next stage.



Return to the specified stage and repeat the activity.



Before using the product, carefully read the Instructions for Use. It contains, among others, indications, contraindications, side effects, recommendations and warnings related to the use of the product.



The above description is not a detailed instruction of conduct. The surgeon decides about choosing the operating procedure.

**[www.chm.eu](http://www.chm.eu)**

Document No            ST/68B  
Date of issue            11.02.2016  
Review date            P-006-20.11.2020

*The manufacturer reserves the right to introduce design changes.  
Updated INSTRUCTIONS FOR USE are available at the following website: [ifu.chm.eu](http://ifu.chm.eu)*

---

I. INTRODUCTION	5
I.1. DESCRIPTION AND INDICATIONS	5
I.2. CONTRAINDICATIONS	5
I.3. IMPLANT FEATURES	6

---

II. IMPLANTS	7
--------------	---

---

III. INSTRUMENTS	8
------------------	---

---

IV. SURGICAL TECHNIQUE	10
IV.1. SURGICAL APPROACH AND PATIENT POSITIONING	10
IV.2. DISCECTOMY	11
IV.3. TRIALING	12
IV.4. ENDPLATES PREPARATION	13
IV.5. IMPLANT PREPARATION	13
IV.6. IMPLANT INSERTION	14
IV.7. ADDITIONAL STABILIZATION	14

---

V. IMPLANT REMOVAL	15
--------------------	----



## I. INTRODUCTION

### I.1. DESCRIPTION AND INDICATIONS

The **ALIF PEEK** Intervertebral Cage system consists of polyetheretherketone (*PEEK*) cages of various widths, heights and angles to adapt best to variety of patients' anatomies.

The **ALIF PEEK** Intervertebral Cages are designed for use with bone grafting for spondylolysis of one level or two contiguous levels of lumbar spine. Anterior, anterolateral or lateral approaches may be used.

The implants are indicated for treatment of degenerative disc disease (*DDD*) and grade 1 spondylolisthesis in lumbar spine from L2 to S1. The **ALIF PEEK** Intervertebral Cages should be used with additional stabilizing devices allowed for surgeries of lumbar spine (e.g.: a system of posterior pedicle screws and rods). Degenerative disc disease (*DDD*) is defined as discogenic back pain with degeneration of the disc confirmed by history and radiographic studies. Patients qualified for treatment should be skeletally mature and have had at least six months of non-operative treatment.

### I.2. CONTRAINDICATIONS



**ALIF intervertebral implants are not intended for cervical spine use.**

Contraindications may be relative and absolute.

The selection of an appropriate implant must be preceded by careful and thorough assessment of patient's state of health.

Certain disease and physiological states such as:

- spine infection,
- morbid obesity,
- mental illness,
- addiction to alcohol or drugs,
- pregnancy,
- intolerance to metals, foreign bodies,
- inadequate tissue coverage or open wounds in the surgical site,

may preclude or reduce the chance of successful outcome.



**A detailed list of contraindications is included in the Instructions for Use (IFU) intended for the product.**

#### WARNINGS

It is not always possible in every patient to achieve a positive result of treatment. This fact is especially true in surgery where other factors related to patients' condition may compromise the results. The proper selection and the compliance of the patient with post-operative recommendations will greatly affect the results. Patients who smoke have been shown to have a higher incidence of bone non-, mal-union. These patients should be informed of this fact and warned of this consequence.



**A detailed list of warnings, precautions and post-operative recommendations is included in the Instructions for Use (IFU) intended for the product.**



**Implants of CHARSPINE spine stabilization system manufactured by ChM have been designed and tested exclusively for use with applicable instruments of ChM. This surgical technique is intended only as a guide. Similarly to other surgical procedures, the surgeon should be thoroughly trained before surgery and must take into account the specific needs of each patient.**

### I.3. IMPLANT FEATURES

#### PEEK

- Stiffness of biocompatible PEEK polymer approximates the patient's bone which provides ideal load sharing attributes.
- Radiolucency of PEEK polymer offers an accurate visualization and assessment of the fusion.
- Radioopaque tantalum markers facilitate intraoperative X-Ray visualization of inserted implant.

#### ANATOMICAL DESIGN

The serrated surface of the implant is convex shaped to fit the anatomy of the disc space.

#### SERRATIONS

Serrated superior and inferior surfaces designed to provide stability by engaging to vertebral endplates.

#### OPEN DESIGN

Big holes for bone graft which allow for ingrowth of bone tissue.

## II. IMPLANTS

## Intervertebral cage, medium

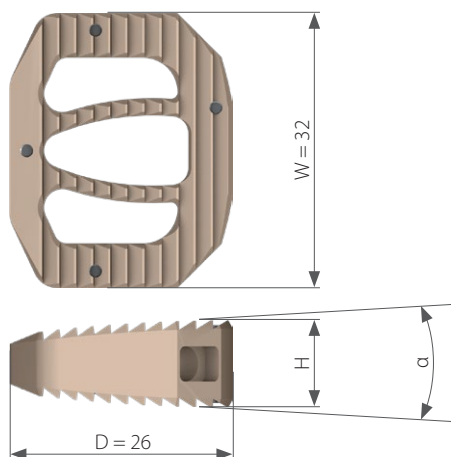

Size	W [mm]	D [mm]	H [mm]	Lordosis angle	
				$\alpha = 8^\circ$	$\alpha = 12^\circ$
MEDIUM	32	26	10	8.4560.010	8.4561.010
			11	8.4560.011	8.4561.011
			13	8.4560.013	8.4561.013
			15	8.4560.015	8.4561.015
			17	8.4560.017	8.4561.017
			19	8.4560.019	8.4561.019

Material: PEEK-



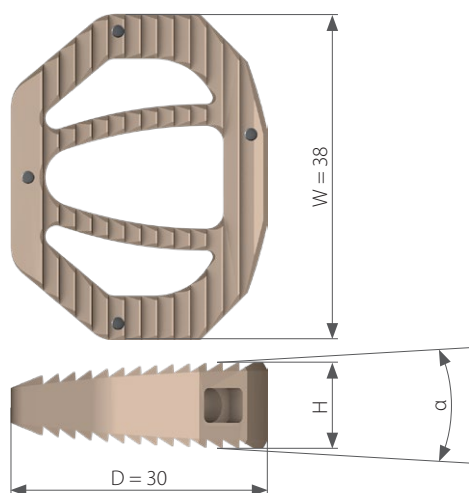







## Intervertebral cage, large

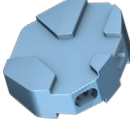
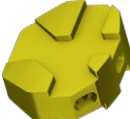

Size	W [mm]	D [mm]	H [mm]	Lordosis angle	
				$\alpha = 8^\circ$	$\alpha = 12^\circ$
LARGE	38	30	10	8.4562.010	8.4563.010
			11	8.4562.011	8.4563.011
			13	8.4562.013	8.4563.013
			15	8.4562.015	8.4563.015
			17	8.4562.017	8.4563.017
			19	8.4562.019	8.4563.019

Material: PEEK-

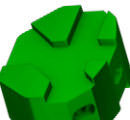
## III. INSTRUMENTS

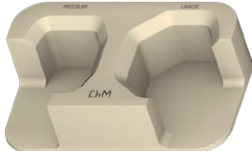
Instrument set for ALIF PEEK Intervertebral Cages 40.6241.000	Name	Pcs	Catalogue no.
	Persuader	2	40.6182.000
	Distraction forceps	1	40.6233.000
	Mallet	1	40.6247.000
	Compactor	1	40.6190.000
	Bone rasp medium H-10	1	40.6183.010
	Bone rasp medium H-11	1	40.6183.011
	Bone rasp medium H-13	1	40.6183.013
	Bone rasp medium H-15	1	40.6183.015
	Bone rasp medium H-17	1	40.6183.017
	Bone rasp medium H-19	1	40.6183.019
	Medium trial H-10/8°	1	40.6184.010
	Medium trial H-10/12°	1	40.6185.010
	Large trial H-10/8°	1	40.6186.010
	Large trial H-10/12°	1	40.6187.010
	Medium trial H-11/8°	1	40.6184.011
	Medium trial H-11/12°	1	40.6185.011
	Large trial H-11/8°	1	40.6186.011
	Large trial H-11/12°	1	40.6187.011
	Medium trial H-13/8°	1	40.6184.013
	Medium trial H-13/12°	1	40.6185.013
	Large trial H-13/8°	1	40.6186.013
	Large trial H-13/12°	1	40.6187.013
	Medium trial H-15/8°	1	40.6184.015
	Medium trial H-15/12°	1	40.6185.015
	Large trial H-15/8°	1	40.6186.015
	Large trial H-15/12°	1	40.6187.015
	Medium trial H-17/8°	1	40.6184.017
	Medium trial H-17/12°	1	40.6185.017
	Large trial H-17/8°	1	40.6186.017
	Large trial H-17/12°	1	40.6187.017
	Medium trial H-19/8°	1	40.6184.019
	Medium trial H-19/12°	1	40.6185.019
	Large trial H-19/8°	1	40.6186.019
	Large trial H-19/12°	1	40.6187.019
	Working stand	1	40.6232.000



Instrument set for ALIF PEEK Intervertebral Cages 40.6241.000	Name	Pcs	Catalogue no.
	Perforated aluminum lid 1/1 595x275x15mm Gray	1	12.0750.200
	Stand for instrument set for ALIF PEEK Intervertebral Cages	1	40.6181.000
	Container with solid bottom 1/1 595x275x86mm	1	12.0750.100

Medium trial

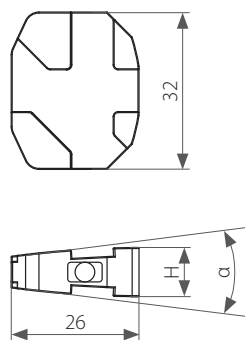

Size	Colors	H [mm]	Lordosis angle	
			$\alpha = 8^\circ$	$\alpha = 12^\circ$
Catalogue no.				
MEDIUM		10	40.6184.010	40.6185.010
		11	40.6184.011	40.6185.011
		13	40.6184.013	40.6185.013
		15	40.6184.015	40.6185.015
		17	40.6184.017	40.6185.017
		19	40.6184.019	40.6185.019

Large trial

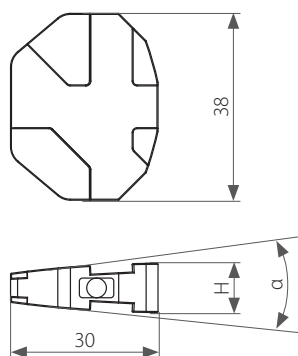

Size	Colors	H [mm]	Lordosis angle	
			$\alpha = 8^\circ$	$\alpha = 12^\circ$
Catalogue no.				
LARGE		10	40.6186.010	40.6187.010
		11	40.6186.011	40.6187.011
		13	40.6186.013	40.6187.013
		15	40.6186.015	40.6187.015
		17	40.6186.017	40.6187.017
		19	40.6186.019	40.6187.019

## IV. SURGICAL TECHNIQUE

### IV.1. SURGICAL APPROACH AND PATIENT POSITIONING

The surgical approach depends on the level to be treated. Surgery is performed utilizing anterior transperitoneal, or anterior retroperitoneal approach (*depending on the surgeon's preference*).

The surgery should be preceded by thorough preoperative plan and carried out with the participation of a vascular surgeon or general surgeon trained to perform spinal surgical approaches.

The operating table should be radiolucent and should allow for intraoperative C-arm movement.

The patient is placed in the supine position to allow anterior access to the lumbar vertebral bodies. During implant placement, an intraoperative adjustability of lordosis using a hinged table or inflatable pillow is often useful.

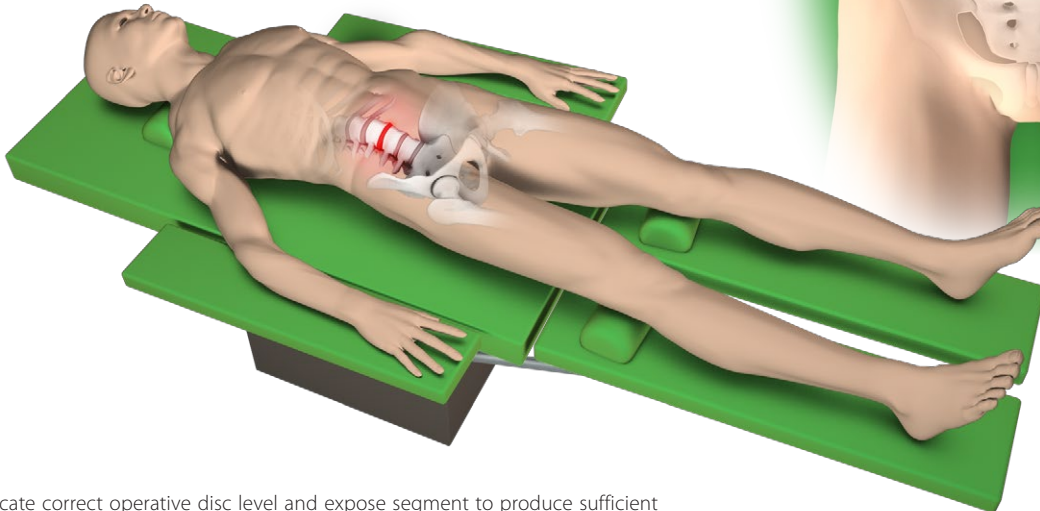
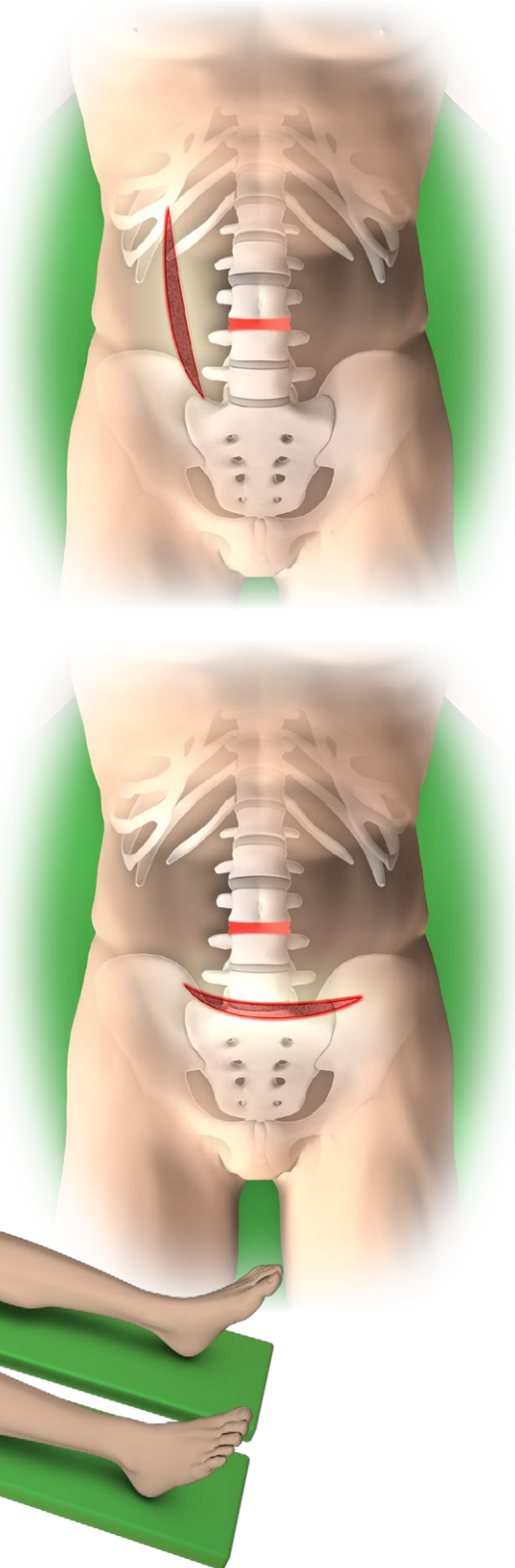

Locate correct operative disc level and expose segment to produce sufficient space on either side of the vertebral midline, equal to the width of the implant (*two implant widths are available, 32mm and 38mm*).

Mark the midline of vertebrae above and below the discectomy site.

## IV.2. DISCECTOMY

Perform a discectomy wide enough to accommodate the chosen size of the implant, ensuring that the posterolateral corners of the vertebral space are freed of disc material.

On this stage, a trial (*medium o large*) may be used to determine the appropriate implant width.

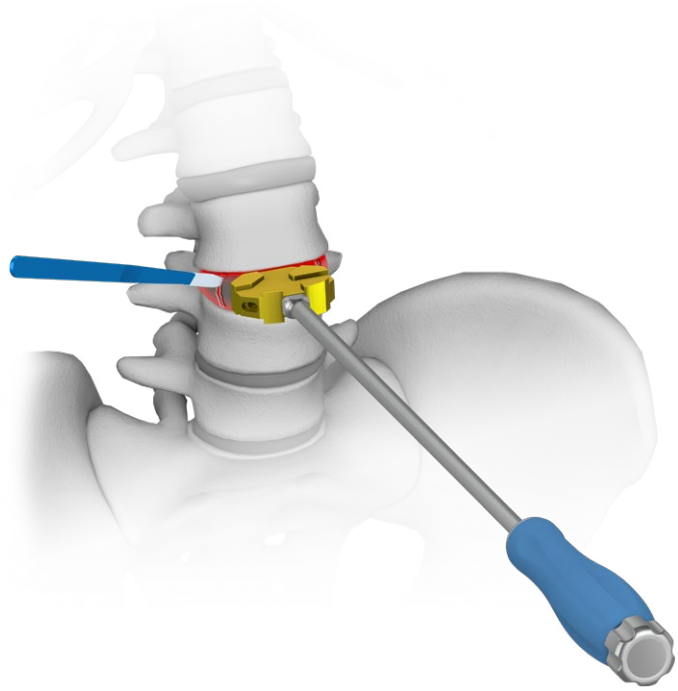

Remove the superficial layers of the cartilaginous endplates. This can be done with instruments such as curettes and rasps.

Adequate preparation of the endplates is important to enhance vascular supply to the implantation site.



Excessive removal of subchondral bone may weaken the vertebral bodies and, consequently, may result in implant subsidence and loss of stability of the segment.



The curettes and rasps are not included to the instrument set.

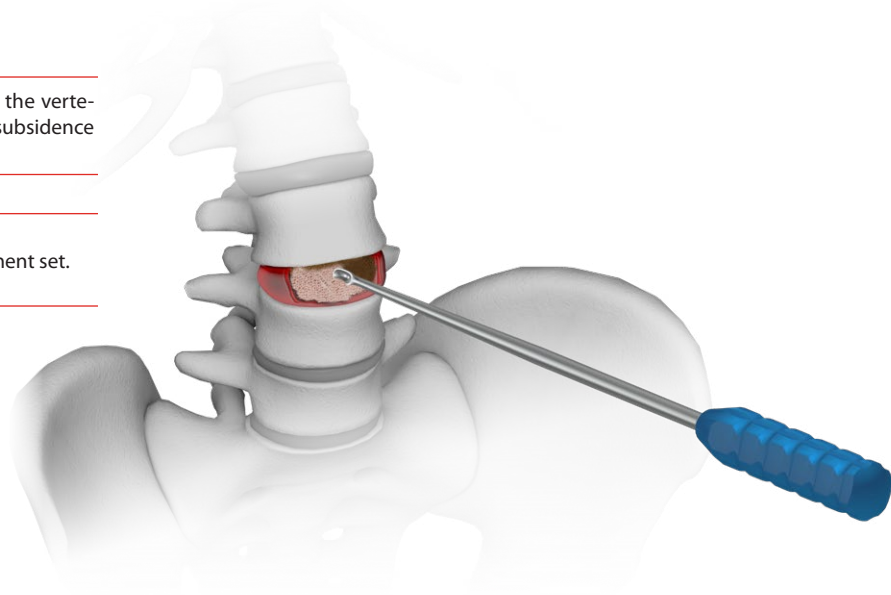

### IV.3. TRIALING

The optimal implant width and height can be determined by using trials [40.6184.xxx], [40.6185.xxx], [40.6186.xxx] and [40.6187.xxx] which are available in two sizes - medium (*width 32mm*) and large (*width 38mm*); two angular versions (*8° and 12°*) and six heights 10mm, 11mm, 13mm, 15mm, 17mm and 19mm.

To facilitate proper selection of the implant, trial implants are laser etched with the size (*medium or large*), height and lordotic angle. Trials are color-coded.

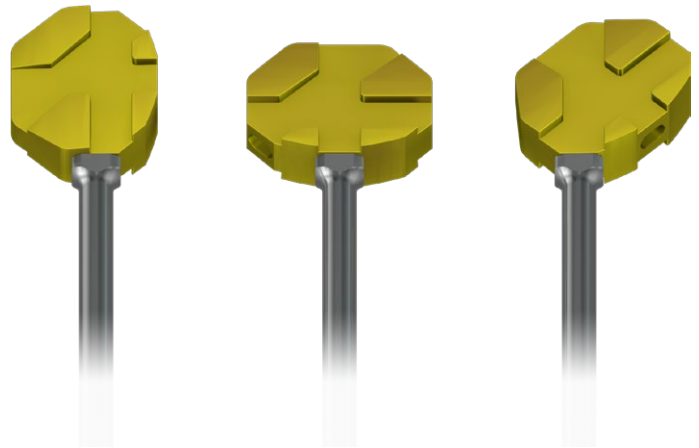

Trials have three slots, which allow the persuader to be mounted with the trial in different positions, to facilitate the insertion depending on the surgical approach.

Select the medium trial 32mm, [40.6184.010] with angle of 8° and 10mm height, attach to the persuader [40.6182.000] and insert it into the discectomy site.

If the medium trial is too narrow, switch it to large trial 38mm, [40.6186.010].

Once the width is determined, use incrementally higher trials until a tight fit is achieved. There should be no gaps between the prepared site and the trial. Use the largest size possible to ensure maximum stability.

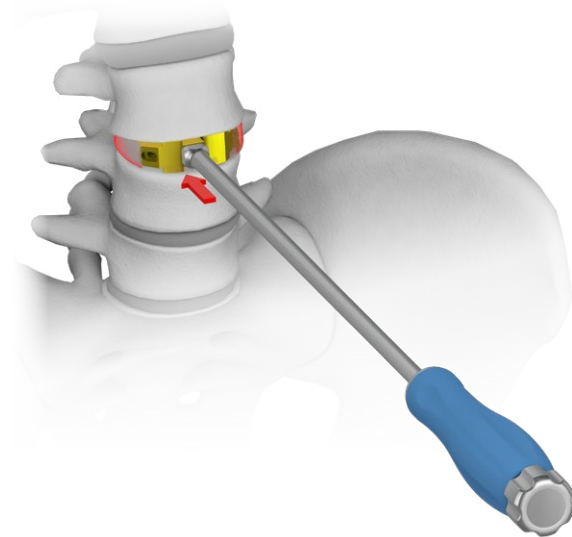

Distraction forceps [40.6233.000] may be used to assist with guiding the trial into the intervertebral space.

An intraoperative lateral X-Ray image can be utilized to illustrate posterior end-plate contact with the trial. If necessary, use the 12° trial instead of 8° to fit better to lumbar lordosis.

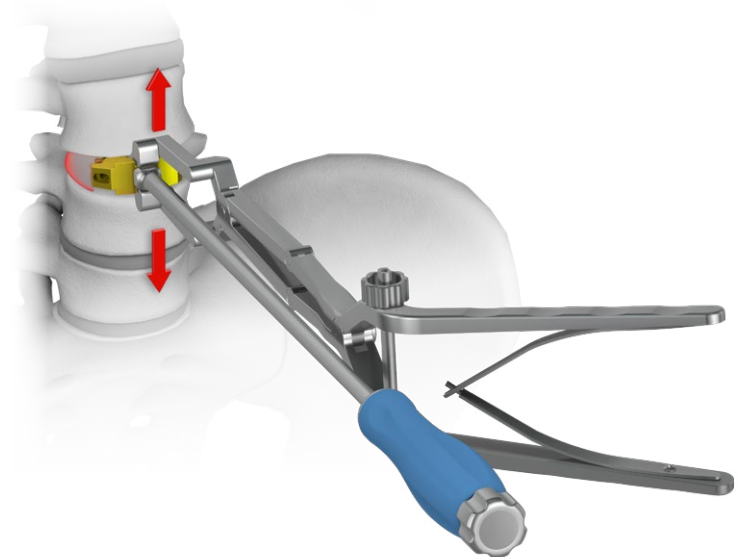

#### IV.4. ENDPLATES PREPARATION

Once final sizing has been determined, use the appropriate sized bone rasp [40.6183.xxx] to complete endplate preparation. Insert rasp attached to the persuader into intervertebral space and remove the cartilage and bone material until bleeding bone is exposed.



Excessive removal of subchondral bone may weaken the vertebral bodies and, consequently, may result in implant subsidence and loss of stability of the segment.

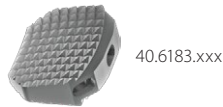

40.6183.xxx

#### IV.5. IMPLANT PREPARATION

Attach the implant to the persuader [40.6182.000] by inserting the tip of the instrument in one of the implant's socket.



Implants have three slots, which allow the persuader to be mounted with the implant in different positions, to facilitate the insertion depending on the surgical approach.

Tighten the locking pin of the persuader by turning its knob clockwise.

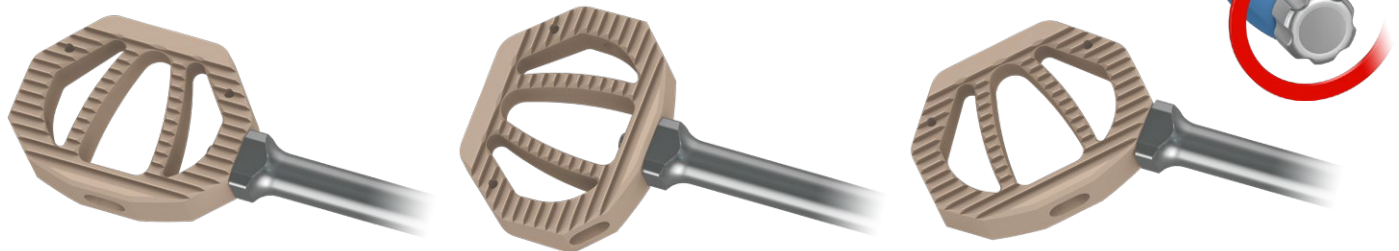

Place the implant on the working table [40.6232.000] and fill with auto-graft material.

The compactor [40.6190.000] may be used to firmly compress the filling material into the implant cavities.

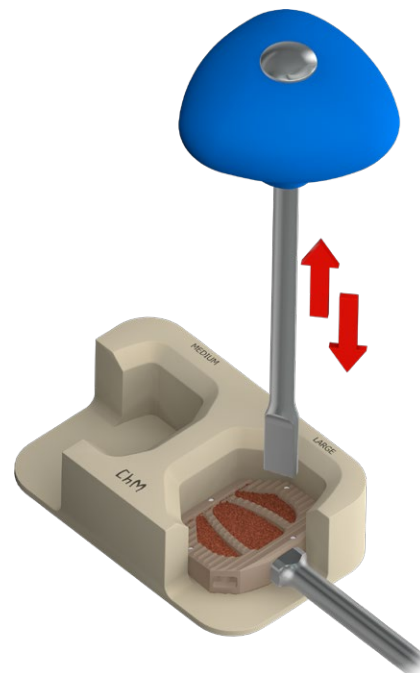
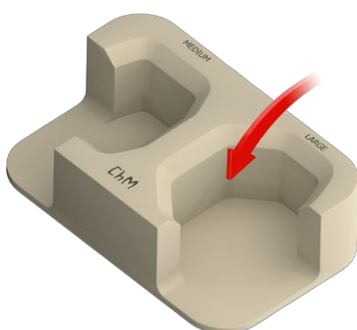

## IV.6. IMPLANT INSERTION

Insert the implant into intervertebral space, taking care to align the sagittal plane of the implant with the previously marked midline.

Make sure the implant is fully engaged with vertebral endplates by lightly tapping with the mallet [40.6247.000] on the persuader knob.  
Remove the persuader by releasing the lock (*turn the knob counter-clockwise*).



Verify proper implant position with the use of an intraoperative lateral X-Ray imaging.

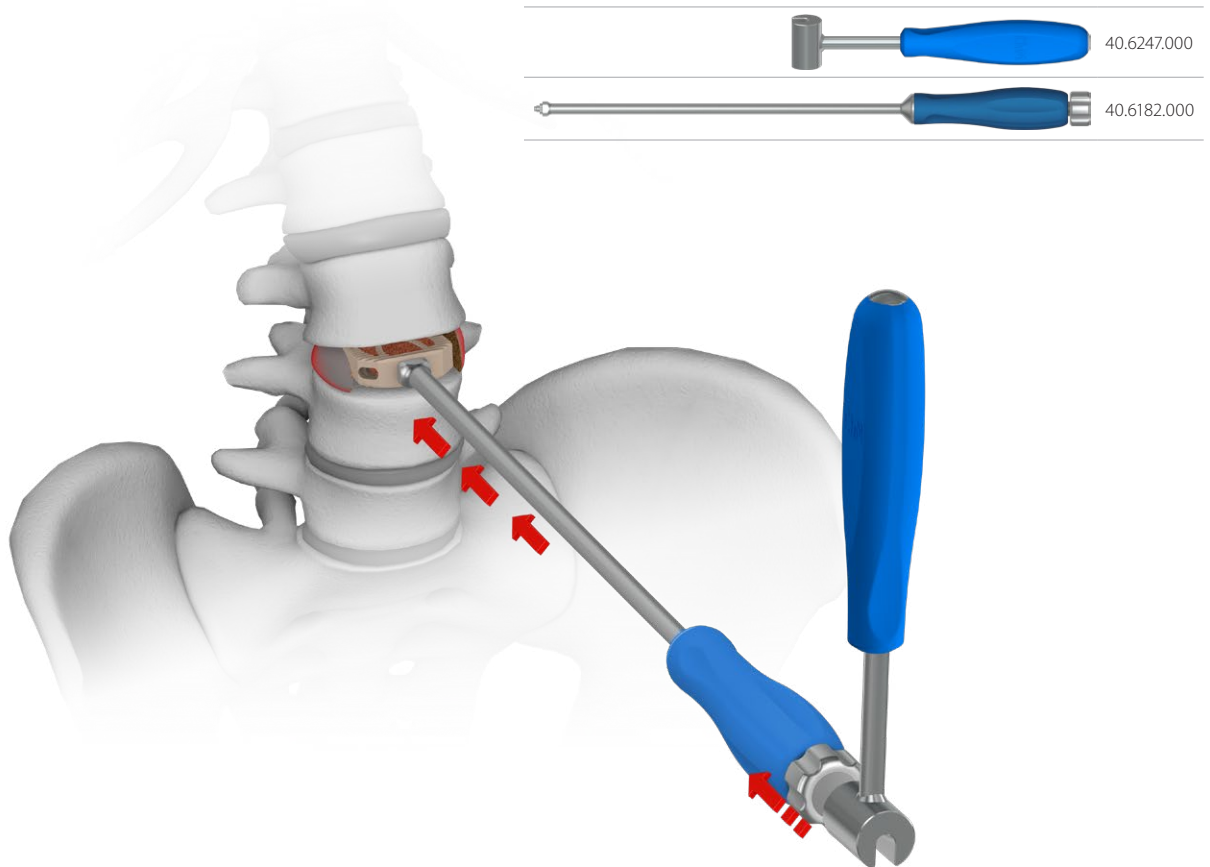

## IV.7. ADDITIONAL STABILIZATION

Having implanted the intervertebral cage, an additional stabilization using the system to stabilize the thoraco-lumbar spine (*CHARSPINE, CHARSPINE 2 systems are recommended*) performed through anterolateral or posterior approach is required.

## V. IMPLANT REMOVAL

Should it become necessary to remove the **ALIF PEEK** cage, the following steps should be taken:

- remove soft tissue from the anterior surface of the implant;
- assembly the persuader [40.6182.000] to the implant;
- distract the vertebrae with use of distraction forceps [40.6233.000];
- if needed, use the mallet [40.6247.000] to punch out the implant from the intervertebral space.

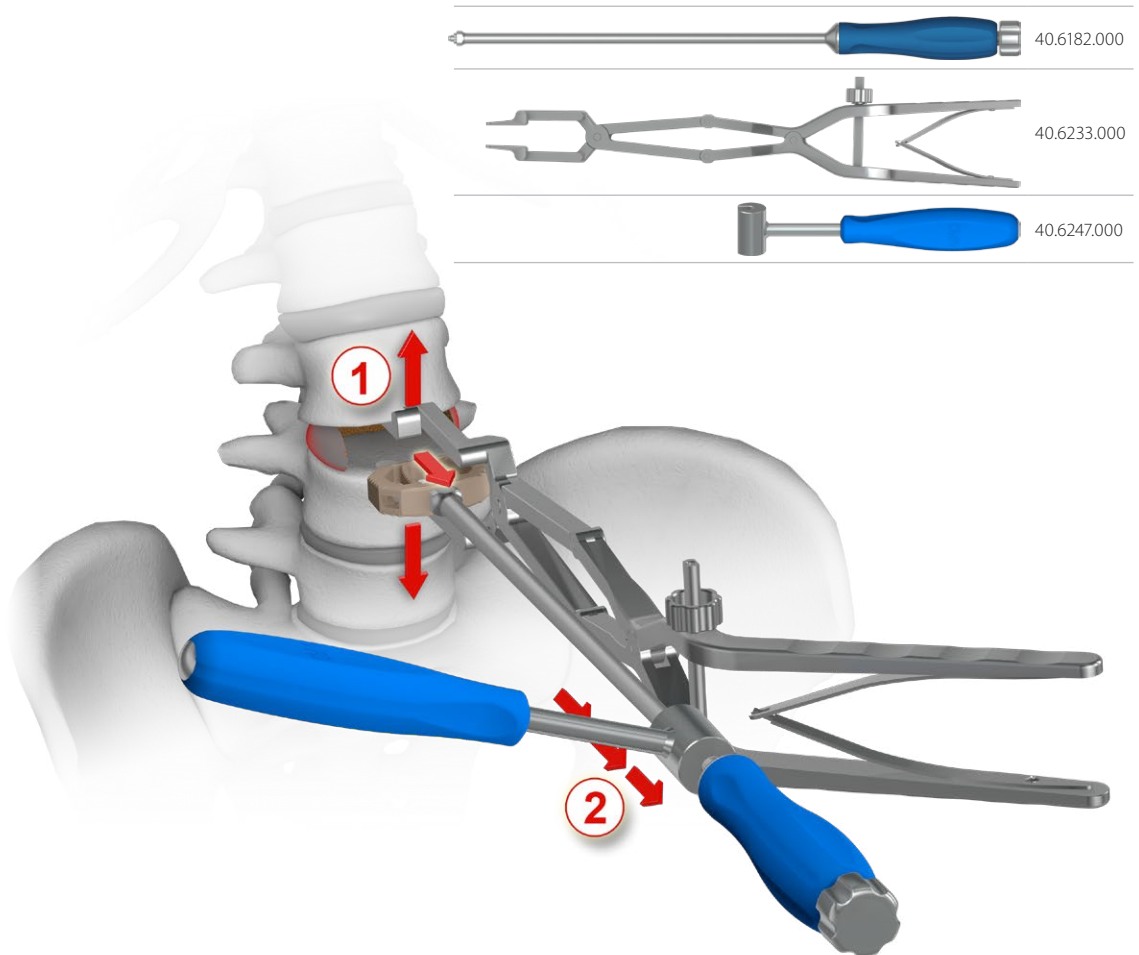







**ChM sp. z o.o.**

Lewickie 3b  
16-061 Juchnowiec Kościelny  
Poland

tel. +48 85 86 86 100

fax +48 85 86 86 101

chm@chm.eu

www.chm.eu



CE 0197