

ChM[®]







5.0 ChM Locked Plating ChLP system 7.0 ChM Locked Plating ChLP system

PEDIATRIC PLATES OF 5.0/7.0ChLP SYSTEM

- *IMPLANTS*
- *INSTRUMENT SET 15.0205.204 / 15.0207.204 / 15.0201.201*
- *SURGICAL TECHNIQUE*



SYMBOLS DESCRIPTION

	Caution - pay attention to a special procedure.
	Perform the activity under X-Ray control.
	Information about the next stages of a procedure.
	Proceed to the next stage.
	Return to the specified stage and repeat the activity.
	Before using the product, carefully read the Instructions for Use. It contains, among others, indications, contraindications, side effects, recommendations and warnings related to the use of the product.
	The above description is not a detailed instruction of conduct. The surgeon decides about choosing the operating procedure.

www.chm.eu

Document No ST/70A
Date of issue 16.03.2016
Review date P-005-25.11.2020

*The manufacturer reserves the right to introduce design changes.
Updated INSTRUCTIONS FOR USE are available at the following website: ifu.chm.eu*

I. INTRODUCTION

Pediatric plates of 5.0ChLP and 7.0ChLP systems are used for stable fixation of varus and valgus deformities of proximal femur and for treatment of proximal femur fractures in children. The plates are a part of the ChLP locking plates system developed by ChM. The presented range of implants is made of titanium and its alloys in accordance with ISO 5832 standard. Quality management systems and the compliance with the requirements of medical directive guarantee high quality of the offered implants.

The implant system includes:

- implants (*plates for osteotomy and fractures, locking screws and standard cortical screws*),
- instrument set used for plate implantation,
- surgical technique.

Indication

Pediatric plates of 5.0ChLP and 7.0ChLP systems are indicated for children and adolescents aged 2 to 16 years old. They may also be used for small-stature adult patients of body weight up to 55 kg.

The plate is intended for the treatment of:

- Inter- and sub-trochanteric varus osteotomies
- Inter- and sub-trochanteric valgus osteotomies
- Inter- and sub-trochanteric derotation osteotomies
- Fractures of the proximal femur

Contraindications:

- active infections at site of planned operation,
- patients that do not conform to the indications,
- patients that are inappropriate to the design and strength of the plate.

Plate selection

There are available two systems of pediatric plates - 5.0ChLP System and 7.0ChLP System. Both plate systems are universal (*can be applied to the left and right lower limb*). However, this is the physician who decides about the plate selection and application.

Plate shaping

It is not recommended to shape the plate. Plate shaping may adversely influence its strength and proper functioning with dedicated instrument set.



Before using the product, carefully read the Instructions for Use. It contains, among others, indications, contraindications, side effects, recommendations and warnings related to the use of the product.



The above description is not a detailed instruction of conduct. The surgeon decides about choosing the operating procedure.

II. IMPLANTS

5.0ChLP System and 7.0ChLP System include plates and cooperating screws. Both locking plates and screws are brown anodised - for 5.0ChLP System, and blue - for 7.0ChLP System.

Plates classification:

Plates for varus osteotomies		
5.0ChLP: 100° - 3.7004.503	7.0ChLP: 100° - 3.7008.503	
5.0ChLP: 110° - 3.7005.503	7.0ChLP: 110° - 3.7009.503	
Plates for valgus osteotomies		
5.0ChLP: 150° - 3.7006.503	7.0ChLP: 150° - 3.7010.503	
Plates for fractures and derotation osteotomies		
5.0ChLP: 120° - 3.7007.503	7.0ChLP: 120° - 3.7011.503	

Plate properties:

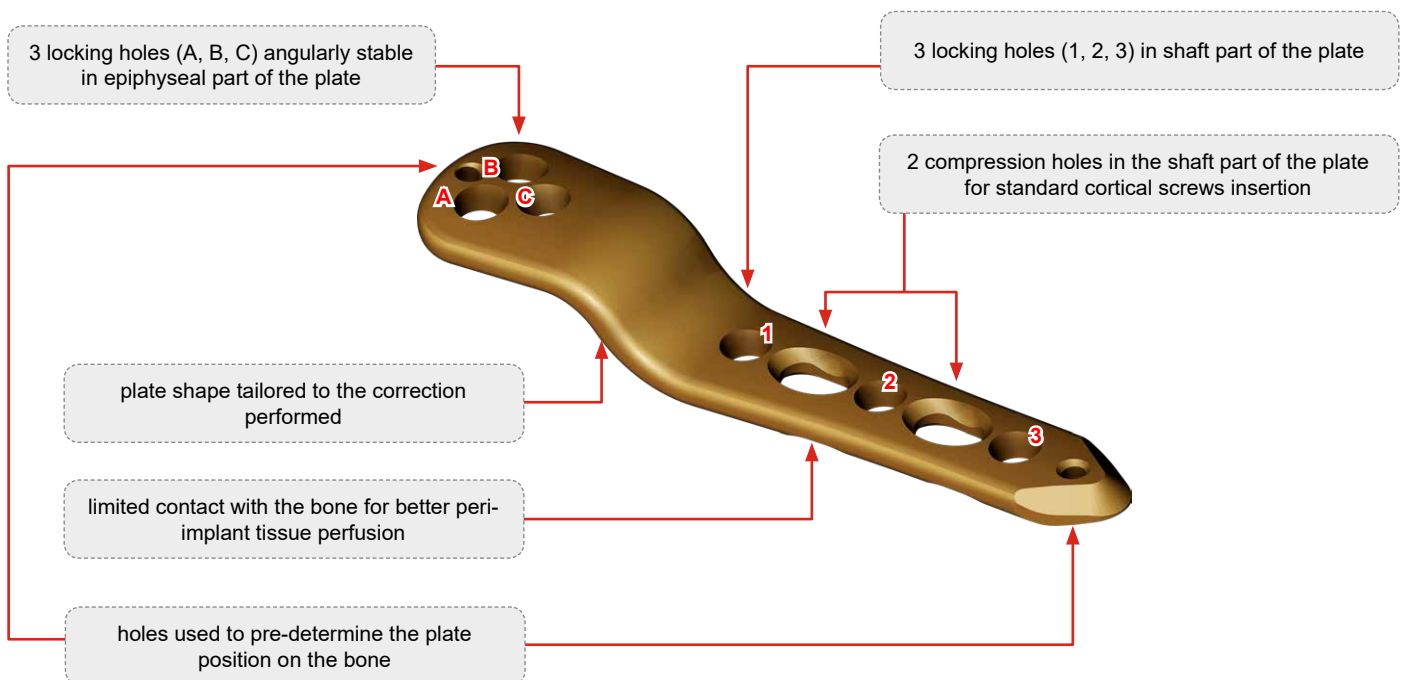

5.0ChLP pediatric femur osteotomy plate

α angle [°]	O	L [mm]	Catalogue no.
100	3	75	3.7004.503
110	3	75	3.7005.503
150	3	59	3.7006.503

O – threaded holes number in shaft part of the plate

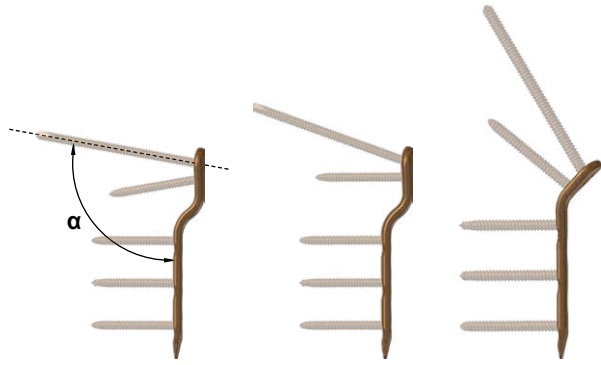

5.0ChLP pediatric femoral plate 120°

α angle [°]	O	L [mm]	Catalogue no.
120	3	66	3.7007.503

O – threaded holes number in shaft part of the plate

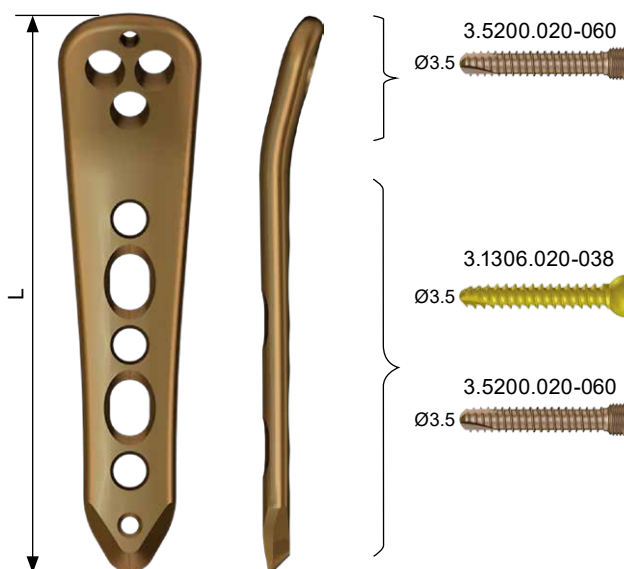
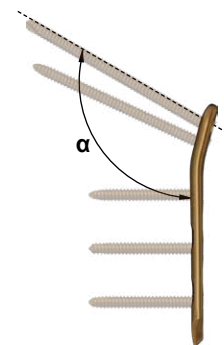

7.0ChLP pediatric femur osteotomy plate

α angle [°]	O	L [mm]	Catalogue no.
100	3	95	3.7008.503
110	3	95	3.7009.503
150	3	80	3.7010.503

O – threaded holes number in shaft part of the plate

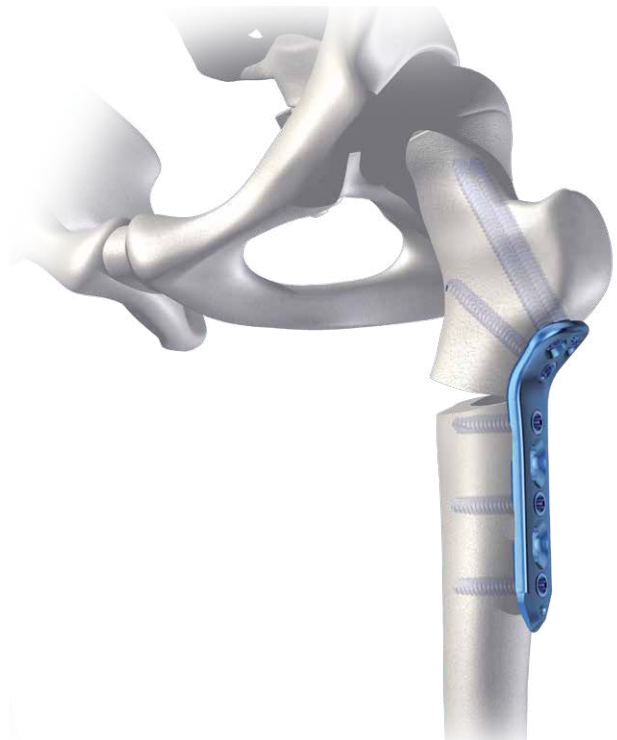
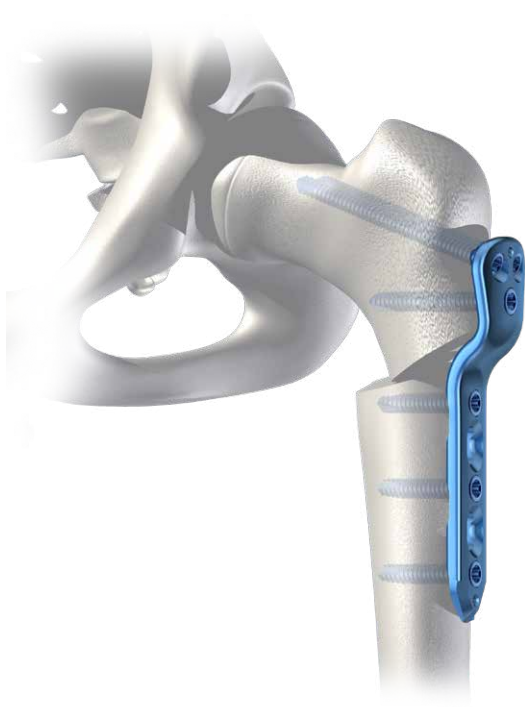
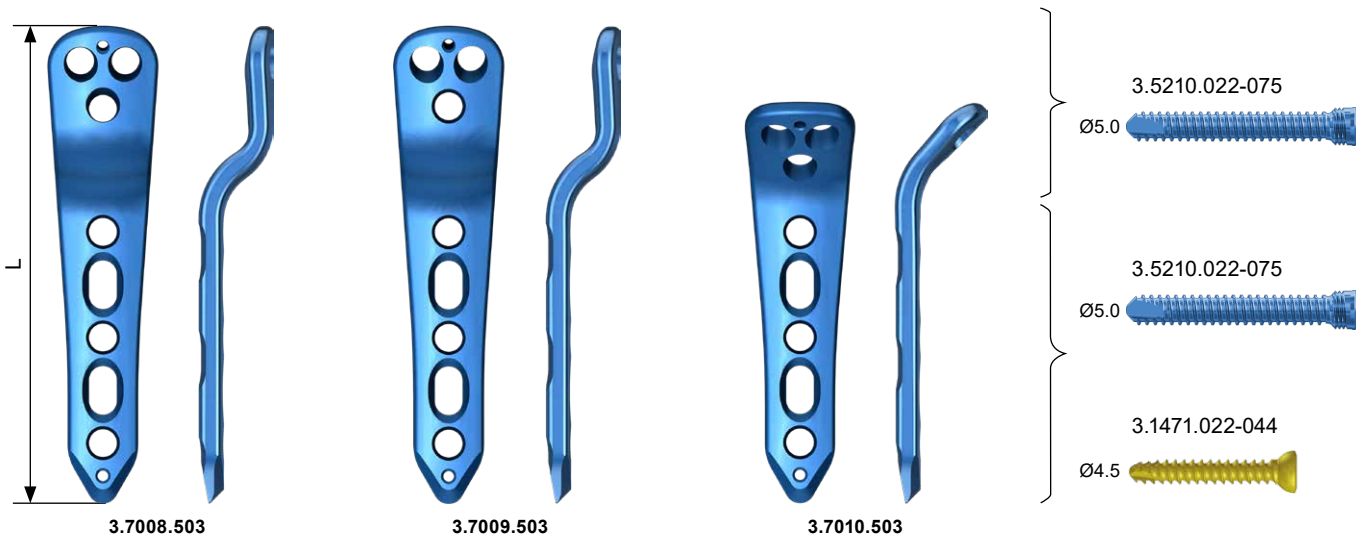
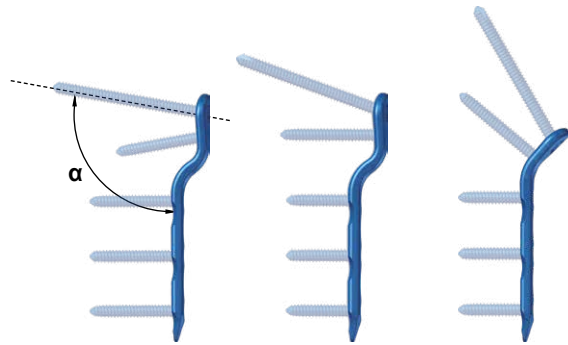

7.0ChLP pediatric femoral plate 120°

TITANIUM ALLOY **Ti**

α angle [°]	O	L [mm]	Catalogue no.
120	3	86	3.7011.503

O – threaded holes number in shaft part of the plate

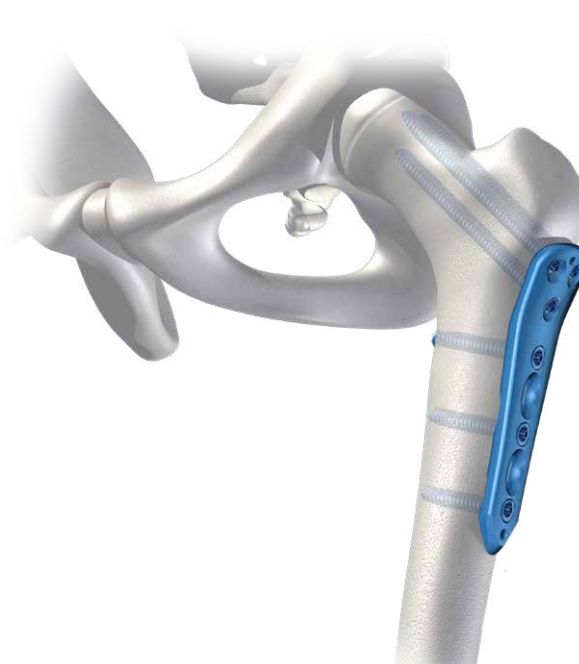
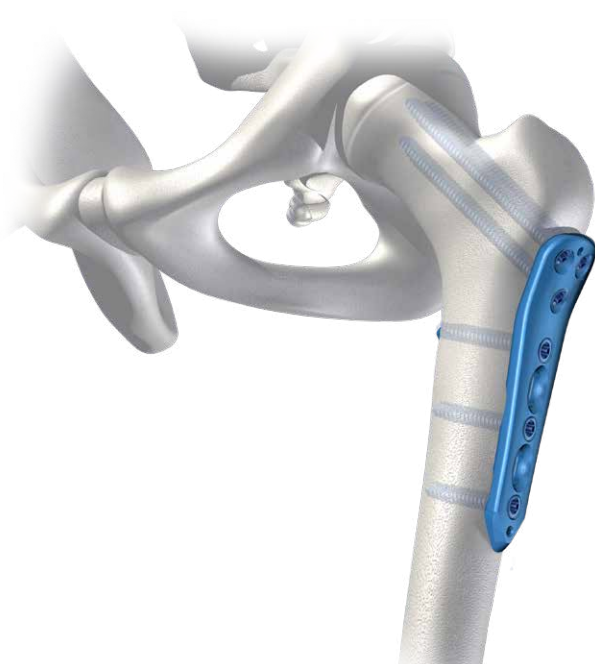
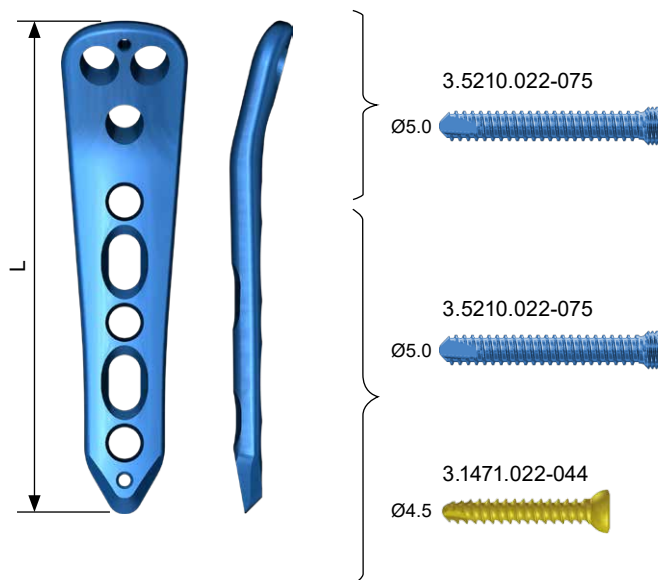
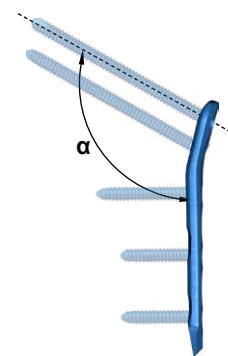

LOCKING ELEMENTS

TITANIUM ALLOY 

5.0ChLP self-tapping screw 3.5

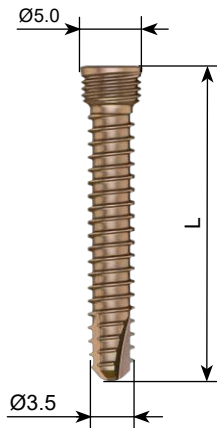

L [mm]	Catalogue no.
20	3.5200.020
22	3.5200.022
24	3.5200.024
26	3.5200.026
28	3.5200.028
30	3.5200.030
32	3.5200.032
34	3.5200.034
36	3.5200.036
38	3.5200.038
40	3.5200.040
42	3.5200.042
44	3.5200.044
46	3.5200.046
48	3.5200.048
50	3.5200.050
52	3.5200.052
54	3.5200.054
56	3.5200.056
58	3.5200.058
60	3.5200.060

Cortical self-tapping screw 3.5

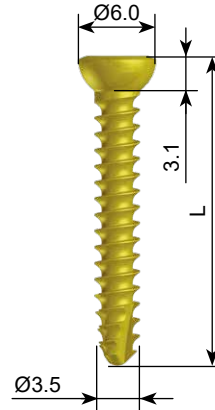

L [mm]	Catalogue no.
20	3.1306.020
22	3.1306.022
24	3.1306.024
26	3.1306.026
28	3.1306.028
30	3.1306.030
32	3.1306.032
34	3.1306.034
36	3.1306.036
38	3.1306.038

Ø screw core		2.8
Ø drill with scale	40.5653.212	2.8
guide sleeve	40.6273.028	5.0/2.8
screwdriver tip	40.5677.000	T15

Ø screw core		2.4
Ø drill with scale	40.5912.212	2.5
compression guide	40.4804.025	2.5
screwdriver tip	40.5677.000	T15

**7.0ChLP self-tapping screw
5.0**

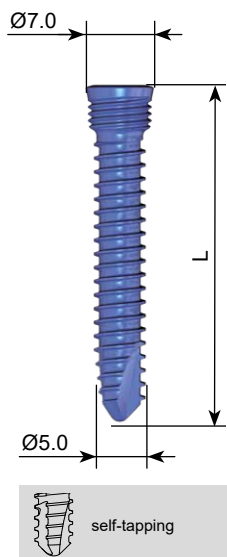

L [mm]	Catalogue no.
22	3.5210.022
24	3.5210.024
26	3.5210.026
28	3.5210.028
30	3.5210.030
32	3.5210.032
34	3.5210.034
36	3.5210.036
38	3.5210.038
40	3.5210.040
42	3.5210.042
44	3.5210.044
46	3.5210.046
48	3.5210.048
50	3.5210.050
52	3.5210.052
54	3.5210.054
56	3.5210.056
58	3.5210.058
60	3.5210.060
65	3.5210.065
70	3.5210.070
75	3.5210.075

**Cortical self-tapping screw
4.5**

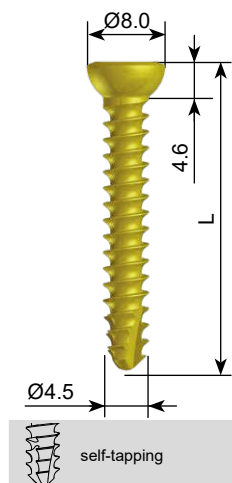

L [mm]	Catalogue no.
22	3.1471.022
24	3.1471.024
26	3.1471.026
28	3.1471.028
30	3.1471.030
32	3.1471.032
34	3.1471.034
36	3.1471.036
38	3.1471.038
40	3.1471.040
42	3.1471.042
44	3.1471.044











Ø screw core		4.0
Ø drill with scale	40.5651.212	4.0
guide sleeve	40.6274.040	7.0/4.0
screwdriver tip	40.5684.200	T25

Ø screw core		3.0
Ø drill with scale	40.5650.212	3.2
compression guide	40.4802.732	3.2
screwdriver tip	40.5684.200	T25

III. INSTRUMENTS



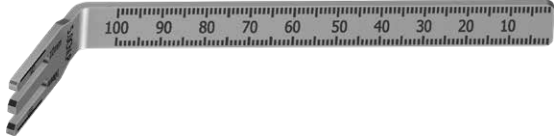







Instrument set for 5.0ChLP pediatric plates 4x4 1/2H

15.0205.204

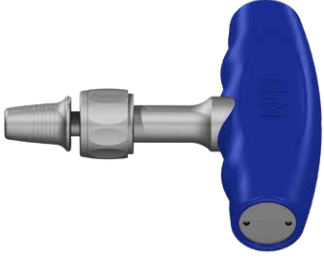
No.		Name	Catalogue No.	Pcs
1		Tray for 5.0ChLP instrument set - pediatric plates 4x4 1/2H	14.0205.204	1
2		Drill with scale 2.5/210	40.5912.212	2
3		Drill with scale 2.8/210	40.5653.212	2
4		Screwdriver tip T15	40.5677.000	1
5		Compression guide 2.5	40.4804.025	1
6		Torque limiting ratchet handle 2Nm	40.6652.000	1
7		Guide sleeve 5.0/2.8	40.6273.028	2
8		Targeter for trochanteric pediatric plates - 5,0ChLP	40.5733.050	1
9		5.0ChLP measure	40.6272.050	1
10		Repositor - 5.0ChLP	40.5735.050	2



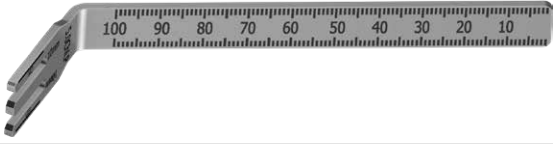





Instrument set for 7.0ChLP pediatric plates 4x4 1/2H

15.0207.204

No.		Name	Catalogue No.	Pcs
1		Tray for 7.0ChLP instrument set - pediatric plates 4x4 1/2H	14.0207.204	1
2		Drill with scale 3.2/210	40.5650.212	2
3		Drill with scale 4.0/210	40.5651.212	2
4		Screwdriver tip T25	40.5684.200	1
5		Compression guide 3.2	40.4802.732	1
6		Torque limiting ratchet handle T 4Nm	40.6660.000	1
7		Guide sleeve 7.0/4.0	40.6274.040	2
8		Guide sleeve 4.0/2.8	40.6275.028	2
9		Targeter for trochanteric pediatric plates - 7.0ChLP	40.5733.070	1
10		7.0ChLP measure	40.6272.070	1
11		Repositor - 7.0ChLP	40.5735.070	2

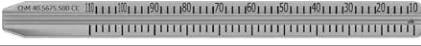
Instrument set for 5.0/7.0ChLP pediatric plates 5x4 1/2H

15.0201.201

No.		Name	Catalogue No.	Pcs
1		Tray for 5.0/7.0ChLP instrument set - pediatric plates 5x4 1/2H	14.0201.201	1
2		Kirschner wire 2.0/210	40.4815.210	4
3		Guide rod 2.8/210	40.6276.210	2
4		Guide rod 2.8 connector	40.6277.028	2
5		Screw length measure	40.5675.500	1
6		Depth measure	40.4639.550	1
7		Targeter guide	40.5734.000	1
8		VERBRUGGE bone holding forceps 9.5x240mm	40.4231.000	1
9		Bone holding forceps 240mm	40.4158.000	1



Stand for 5.0ChLP screws 4x2 H

14.0205.505

	5.0ChLP self-tapping screw 3.5																						
	L [mm]	20	22	24	26	28	30	32	34	36	38	40	42	44	46	48	50	52	54	56	58	60	
	Pcs	4	4	4	4	4	4	4	4	4	4	4	4	4	4	4	4	4	4	4	4	4	
Cortical self-tapping screw 3.5																							
L [mm]	20	22	24	26	28	30	32	34	36	38													
Pcs	2	2	2	2	2	2	2	2	2	2													

* Stand does not include implants



Stand for 7.0ChLP screws 4x2 H





14.0207.503

	7.0ChLP self-tapping screw 5.0																							
	L [mm]	22	24	26	28	30	32	34	36	38	40	42	44	46	48	50	52	54	56	58	60	65	70	75
	Pcs	4	4	4	4	4	4	4	4	4	4	4	4	4	4	4	4	4	4	4	4	4	4	4
Cortical self-tapping screw 4.5																								
L [mm]	22	24	26	28	30	32	34	36	38	40	42	44												
Pcs	2	2	2	2	2	2	2	2	2	2	2	2												

* Stand does not include implants

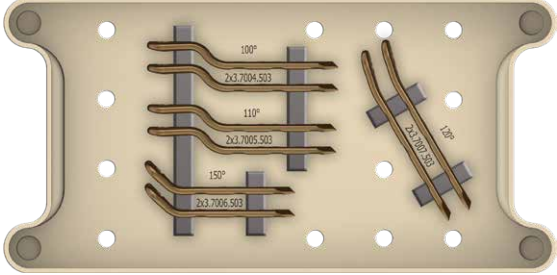



Tray for 5.0ChLP pediatric plates 4x2 1/2H

14.0205.418

	5.0ChLP pediatric femur osteotomy plate 100° 3hol.		
	Catalogue No.	3.7004.503	
	Pcs	2	
	5.0ChLP pediatric femur osteotomy plate 110° 3hol.		
	Catalogue No.	3.7005.503	
	Pcs	2	
	5.0ChLP pediatric femur osteotomy plate 150° 3hol.		
	Catalogue No.	3.7006.503	
	Pcs	2	
	5.0ChLP pediatric femoral plate 120° 3hol.		
	Catalogue No.	3.7007.503	
	Pcs	2	
	* Tray does not include implants		

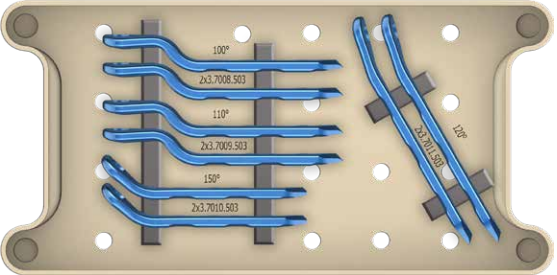
Tray for 7.0ChLP pediatric plates 4x2 1/2H

14.0207.409

	7.0ChLP pediatric femur osteotomy plate 100° 3hol.		
	Catalogue No.	3.7008.503	
	Pcs	2	
	7.0ChLP pediatric femur osteotomy plate 110° 3hol.		
	Catalogue No.	3.7009.503	
	Pcs	2	
	7.0ChLP pediatric femur osteotomy plate 150° 3hol.		
	Catalogue No.	3.7010.503	
	Pcs	2	
	7.0ChLP pediatric femoral plate 120° 3hol.		
	Catalogue No.	3.7011.503	
	Pcs	2	
	* Tray does not include implants		

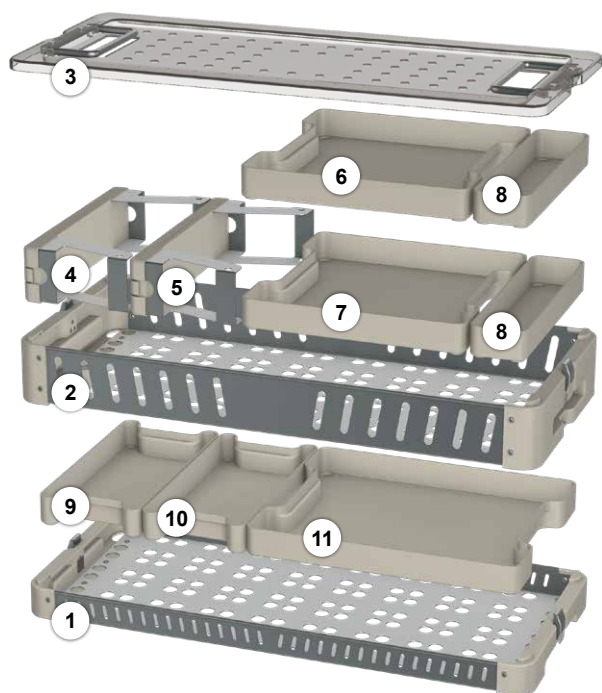

Set for 5.0ChLP/7.0ChLP pediatric 15.0201.001

No.	Name	Catalogue	Pcs
1	Container for pediatric ChLP 9x4 1/2H	14.0201.104	1
2	Container for pediatric ChLP 9x4 H	14.0201.103	1
3	Container lid for pediatric ChLP 9x4 H	14.0201.105	1
4	Stand for 5.0ChLP screws 4x2 H	14.0205.505	1
5	Stand for 7.0ChLP screws 4x2 H	14.0207.503	1
6	Instrument set for 5.0ChLP pediatric plates 4x4 1/2H	15.0205.204	1
7	Instrument set for 7.0ChLP pediatric plates 4x4 1/2H	15.0207.204	1
8	Tray 4x1 1/2H	14.0000.201	2
9	Tray for 5.0ChLP pediatric plates 4x2 1/2H	14.0205.418	1
10	Tray for 7.0ChLP pediatric plates 4x2 1/2H	14.0207.409	1
11	Instrument set for 5.0/7.0ChLP pediatric plates 5x4 1/2H	15.0201.201	1

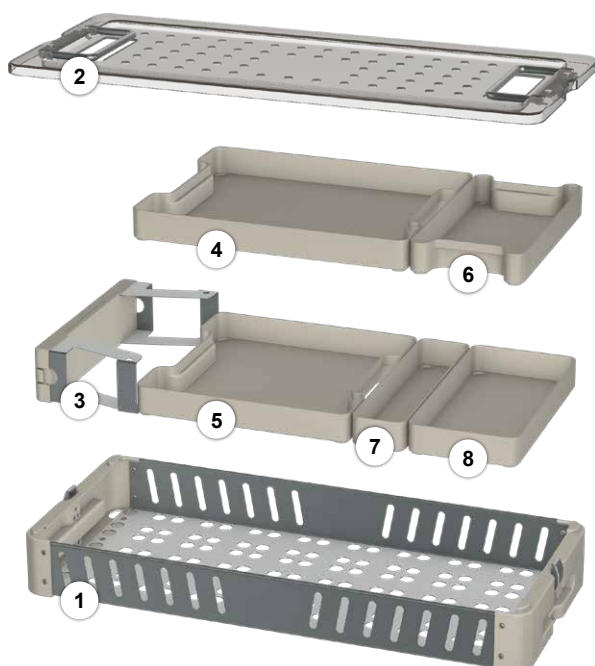

Set for 5.0ChLP pediatric

No.	Name	Catalogue No.
1	Container for pediatric ChLP 9x4 H	14.0201.103
2	Container lid for pediatric ChLP 9x4 H	14.0201.105
3	Stand for 5.0ChLP screws 4x2 H	14.0205.505
4	Instrument set for 5.0/7.0ChLP pediatric plates 5x4 1/2H	15.0201.201
5	Instrument set for 5.0ChLP pediatric plates 4x4 1/2H	15.0205.204
6	Tray for 5.0ChLP pediatric plates 4x2 1/2H	14.0205.418
7	Tray 4x1 1/2H	14.0000.201
8	Tray 4x2 1/2H	14.0000.202

Set for 7.0ChLP pediatric

No.	Name	Catalogue No.
1	Container for pediatric ChLP 9x4 H	14.0201.103
2	Container lid for pediatric ChLP 9x4 H	14.0201.105
3	Stand for 7.0ChLP screws 4x2 H	14.0207.503
4	Instrument set for 5.0/7.0ChLP pediatric plates 5x4 1/2H	15.0201.201
5	Instrument set for 7.0ChLP pediatric plates 4x4 1/2H	15.0207.204
6	Tray for 7.0ChLP pediatric plates 4x2 1/2H	14.0207.409
7	Tray 4x1 1/2H	14.0000.201
8	Tray 4x2 1/2H	14.0000.202

IV. PATIENT POSITIONING

It is recommended that patient be positioned supine (a) or lateral (b).

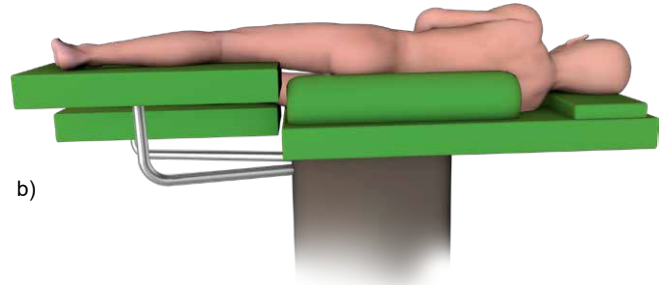
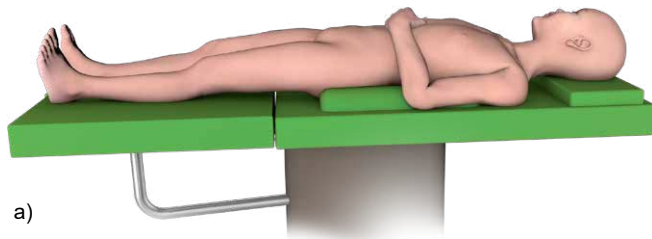

V. SURGICAL APPROACH

Hip, anterior-lateral or lateral approach is recommended. Perform the incision centrally over the greater trochanter and end it above the top of the trochanter.

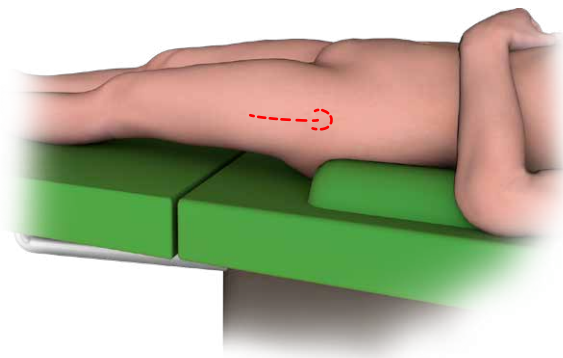

VI. SURGICAL TECHNIQUE

VI.1. VARUS/VALGUS OSTEOTOMIES

VI.1.1. PRE-OPERATIVE PLANNING

a) Planning methods

Pre-operative planning may be performed using two methods:

- **method 1** - planning with fixed neck/shaft (*CCD*) angle,
- **method 2** - planning with calculated neck/shaft (*CCD*) angle.

The surgeon has to decide before the preoperative planning which technique to use.

Selection of the method for preoperative planning is dependent on the desired neck/shaft angle. If the neck/shaft angle to be received coincides with the angle of the plate (100° , 110° , 150°), it is recommended to choose first planning method. In other cases, it is recommended to use the other method.

b) Determination of the anatomical axes of the hip joint

It is recommended to take the AP X-Ray image of both hips in abduction of $20\text{-}25^\circ$ with maximum internal rotation.

Determine anatomical axes of the pathologic hip on the X-Ray image (*Fig. 1*).

c) Plate selection

The appropriate plate must be determined before the surgery. The surgeon makes that choice, from the following:

a) Varus osteotomy

Plates 100° , 110° are used when the desired angle corresponds to the plate angle. When the angles differ, plate 110° should be used.

b) Valgus osteotomy

For valgus osteotomy use plate 150° .

VI.1.1.1. Planning method with fixed neck/shaft (*CCD*) angle (method 1)

The method is used when the desired neck/shaft (*CCD*) angle corresponds to the plate angle (100° , 110° , 150°). A prerequisite is the introduction of the positioning wire parallel to the real axis of the femoral neck in the AP position.

Determination of the actual neck/shaft angle is based on the X-Ray of the hip in AP position (*Fig. 1*). The angle, determined using the X-Ray, is set on the targeter guide when the positioning wire is introduced (see *VI.1.4.*).

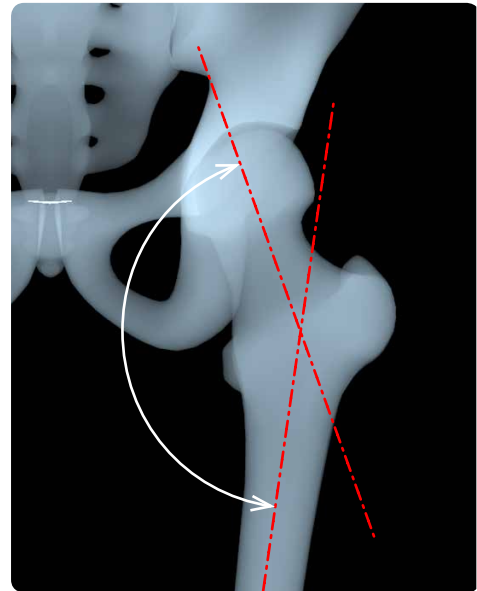
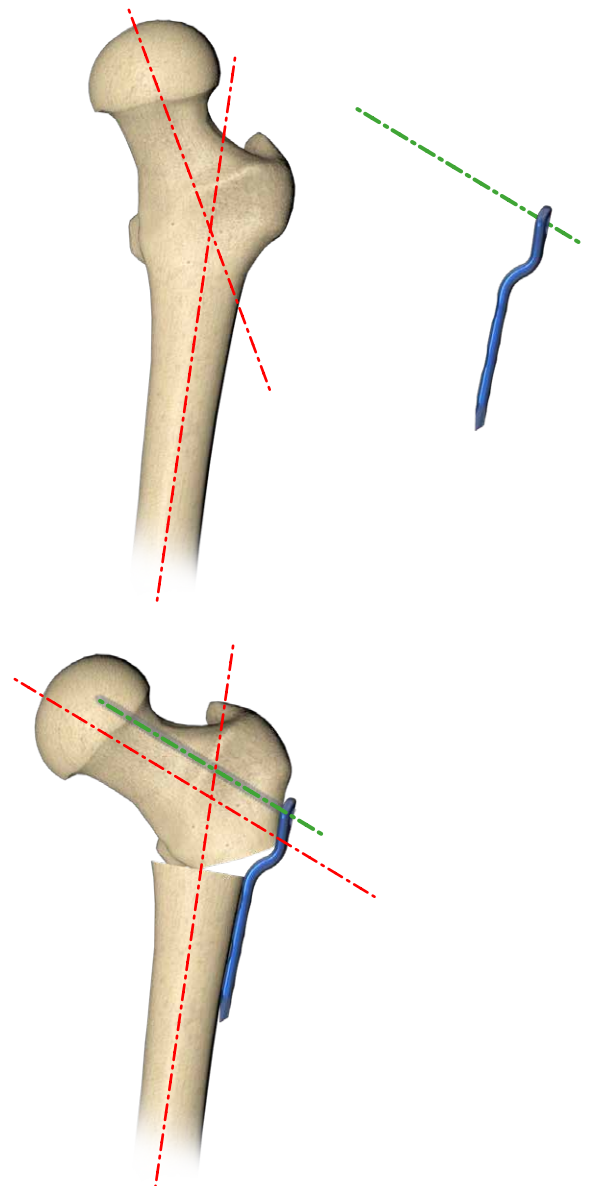

FIG. 1



VI.1.1.2. Planning method with calculated neck/shaft (CCD) angle (method 2)

The method is used when the neck/shaft angle to be received does not coincide with the angle of the plate (100°, 110°, 150°).

The real neck/shaft angle and its planned correction (α_k) are calculated as follows:

1. Take the X-Ray image of the pathologic hip and determine its anatomical axes (see V.1.1.b),
 2. Determine the desired neck/shaft angle,
 3. Determine the correction angle (α_k);
- α_k - is the angle between the axis of pathological neck of the hip joint and the desired axis of the neck (Fig. 2).

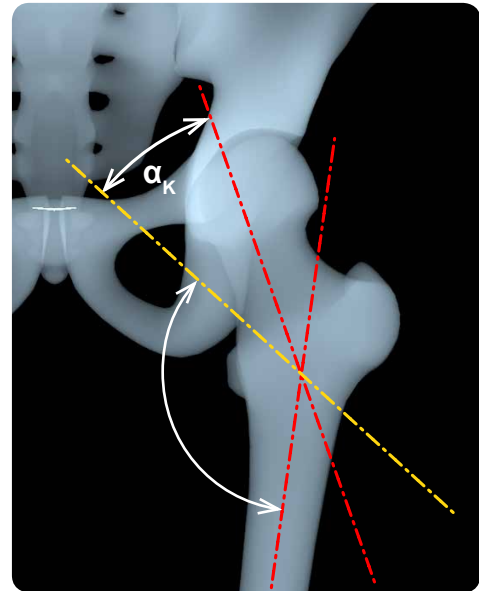

FIG. 2

Exemplary calculation of the angle of insertion of the positioning Kirschner wire (α)

Symbols:

- α - the angle of insertion of the positioning Kirschner wire,
- α_k - correction angle (calculated from VI.1.1.2),
- α_s - plate angle (110° for varus osteotomy, 150° for valgus osteotomy).

varus osteotomy:

$$\alpha = \alpha_k + \alpha_s$$

Example:

$\alpha_k = 20^\circ$,
 $\alpha_s = 110^\circ$,
 then $\alpha = 20^\circ + 110^\circ = 130^\circ$

valgus osteotomy:

$$\alpha = \alpha_s - \alpha_k$$

Example:

$\alpha_s = 150^\circ$,
 $\alpha_k = 20^\circ$,
 then $\alpha = 150^\circ - 20^\circ = 130^\circ$

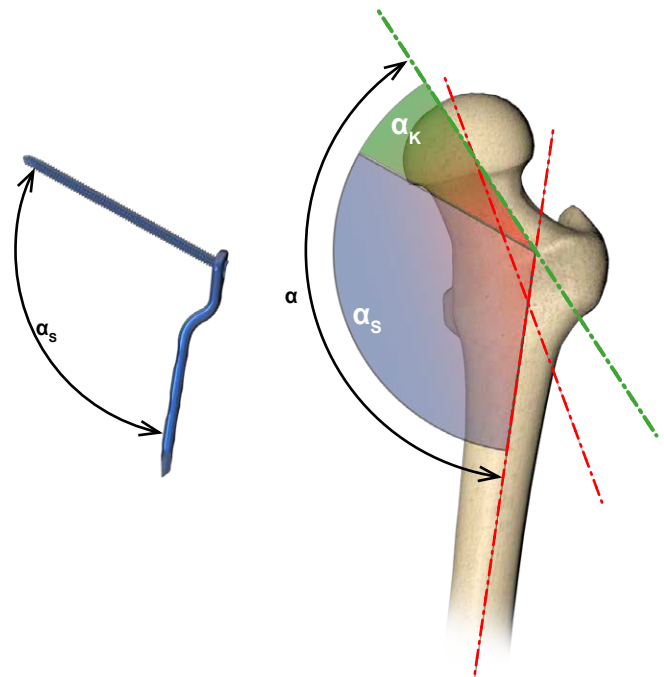

NOTE: the angle correction α_k used as an example!

VI.1.2. KIRSCHNER WIRE INSERTION

Localize the trochanteric epiphysis and introduce the Kirschner wire 2.0/210 [40.4815.210] parallel to the axis of the femoral neck (*under X-Ray control*).

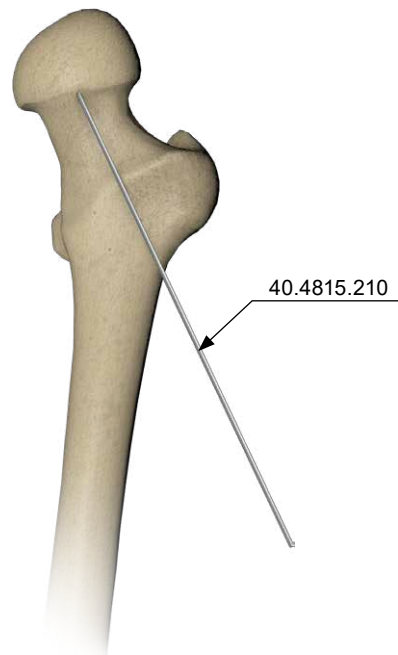

VI.1.3. SETTING OF THE INTRODUCTION ANGLE OF THE POSITIONING KIRSCHNER WIRE

The introduction angle of the positioning Kirschner wire determined from method 1:

Set the determined actual neck/shaft angle on the targeter guide [40.5734.000] and tighten the fixing screw using guide rod 2.8 connector [40.6277.028].

The introduction angle of the positioning Kirschner wire determined from method 2:

Set the calculated angle of the insertion of the positioning Kirschner wire 2.0/210 (α) on the targeter guide [40.5734.000] and tighten the fixing screw using guide rod 2.8 connector [40.6277.028].

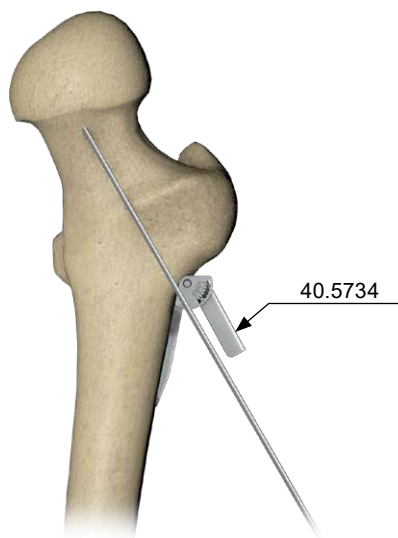
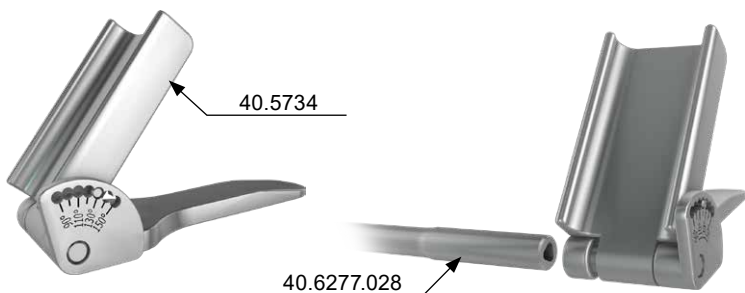

VI.1.4. INTRODUCTION OF THE POSITIONING KIRSCHNER WIRE

Place the targeter guide [40.5734.000] on the femur; the arm of the targeter should be parallel to the Kirschner wire 2.0/210 [40.4815.210].

Insert targeter for trochanteric pediatric plates - 5.0ChLP [40.5733.050].	Insert targeter for trochanteric pediatric plates - 7.0ChLP [40.5733.070].

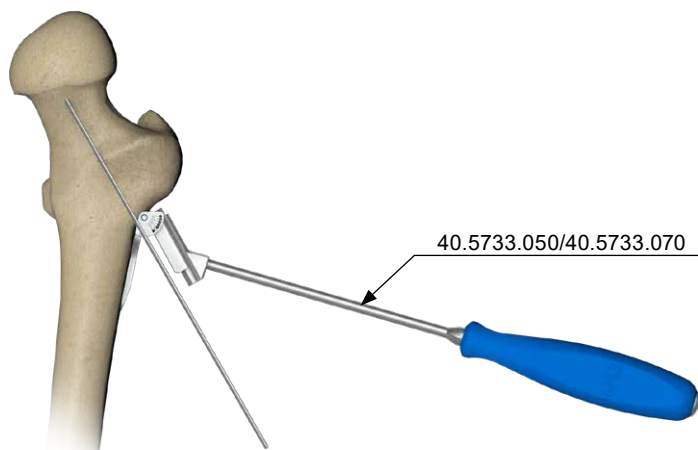

Introduce positioning Kirschner wire 2.0/210 [40.4815.210] through the targeter hole.

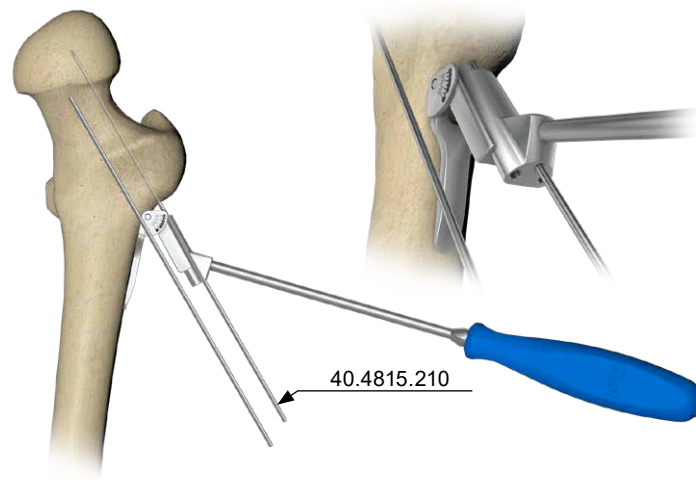

NOTE: The entry point of the positioning Kirschner wire 2.0/210 is located 5-6 mm below the trochanteric epiphysis in the AP projection. Insert the wire acc. to the femoral neck axis in the axial projection, parallel to the Kirschner wire of 2.0/210 [40.4815.210] (under X-Ray control).

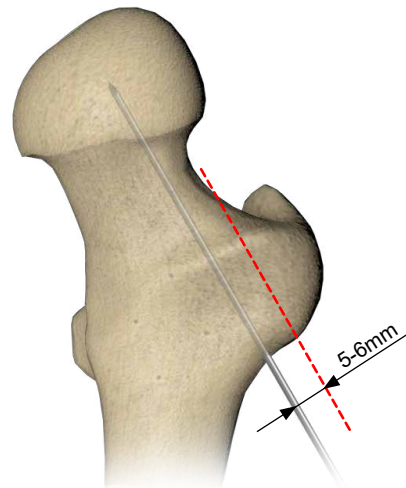

VI.1.5. PLATE GUIDE RODS INSERTION

Introduce two guide rods 2.8/210 [40.6276.210] into holes of the targeter. In order to avoid a collision when inserting guide rods, use guide rod 2.8 connector [40.6277.028].

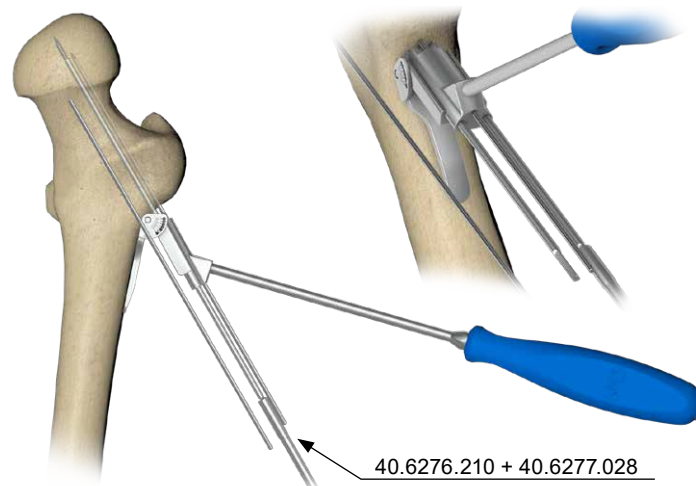



NOTE: Introduce guide rods into the femoral neck under X-Ray control. Avoid penetration of the epiphyseal cartilage of the femoral head!

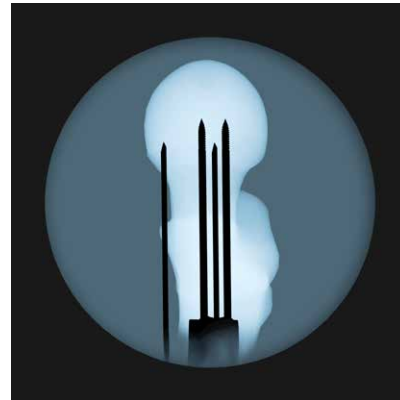

Remove positioning Kirschner wire 2.0/210 [40.4815.210].

Remove targeter for trochanteric pediatric plates - 5.0ChLP [40.5733.050].	Remove targeter for trochanteric pediatric plates - 7.0ChLP [40.5733.070].
Remove targeter guide [40.5734.000].	

In order to facilitate the disassembly, it is recommended to loosen the fixing screw in the targeter guide [40.5734.000].

VI.1.6. OSTEOTOMY

a) Apply 5.0ChLP measure [40.6272.050] to guide rods and mark osteotomy place.	a) Apply 7.0ChLP measure [40.6272.070] to guide rods and mark osteotomy place.
varus osteotomy	
The optimal position for varus osteotomy is located approximately 10 mm below the place guide rods are inserted.	The optimal position for varus osteotomy is located approximately 13 mm below the place guide rods are inserted.

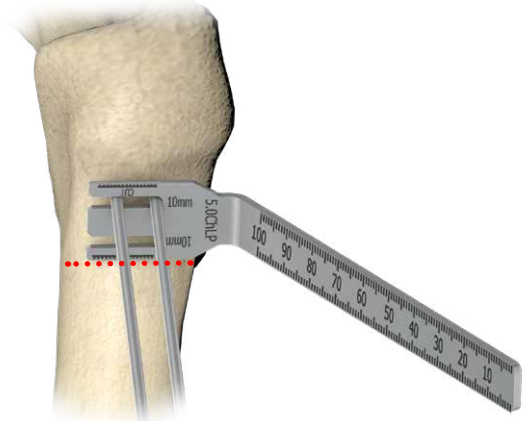
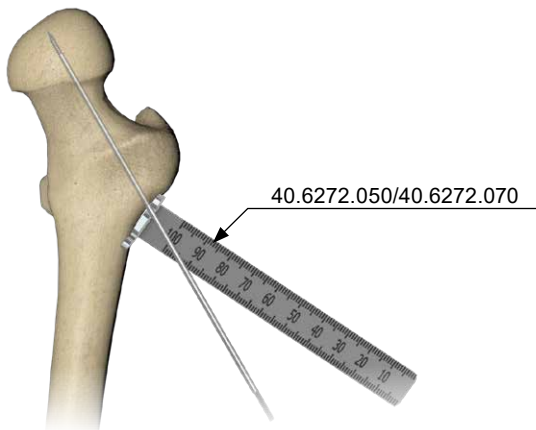

valgus osteotomy

The optimal position for valgus osteotomy is located 18 mm below the place guide rods are inserted.

The optimal position for valgus osteotomy is located approximately 23 mm below the place guide rods are inserted.

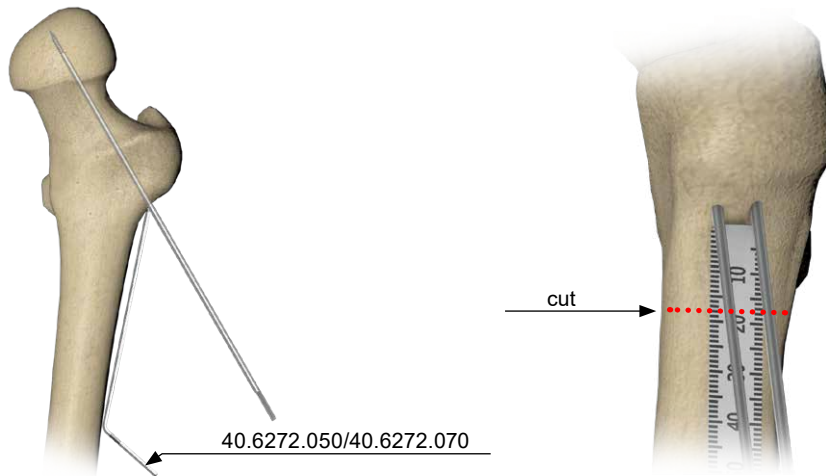

b) Perform osteotomy perpendicular to the shaft of the femur.

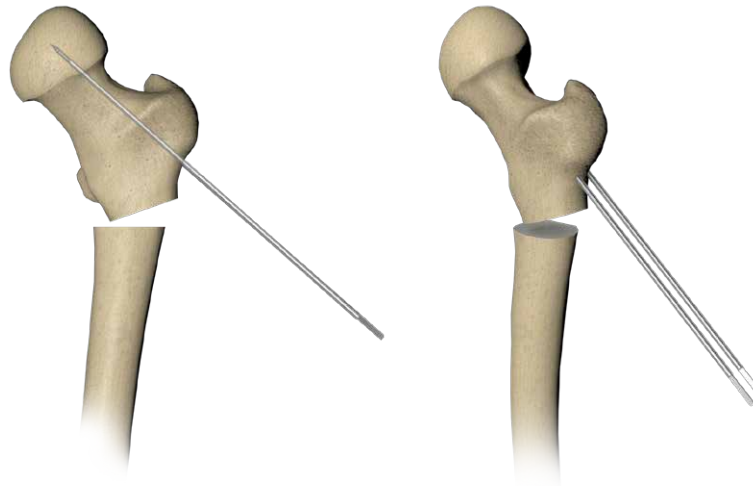

VI.1.7. PLATE INSERTION

VI.1.7.1. Guide sleeves insertion



Insert two guide sleeves 5.0/2.8 [40.6273.028] into holes A and B of the plate.

Lock two guide sleeves 4.0/2.8 [40.6275.028] in guide sleeves 7.0/4.0 [40.6274.040] and then insert into holes A and B of the plate.

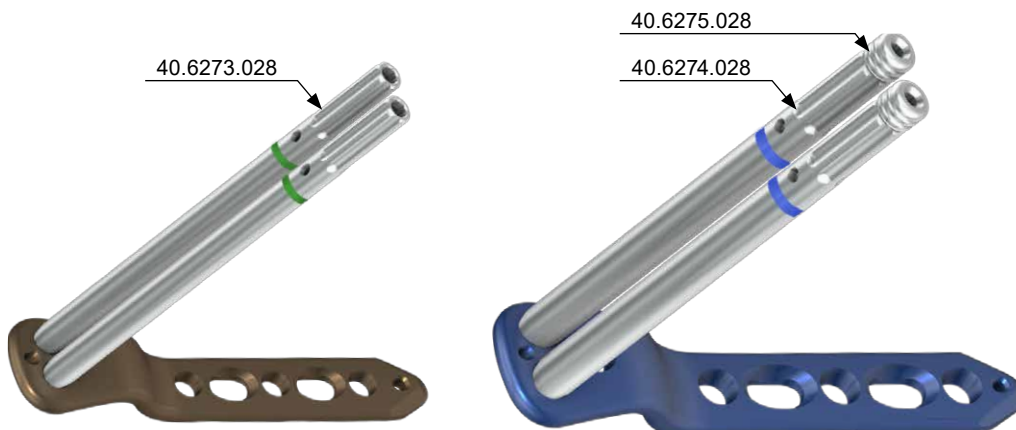

VI.1.7.2. Plate positioning on the bone

Insert the plate through the guide rods.

Use bone holding forceps 240mm [40.4158.000] to facilitate plate insertion and to hold the proximal part of the femur.

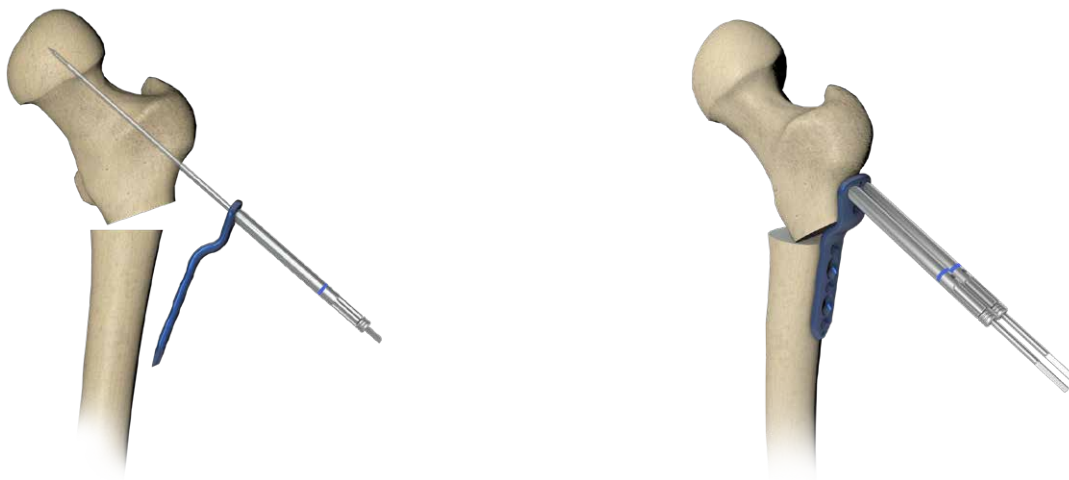

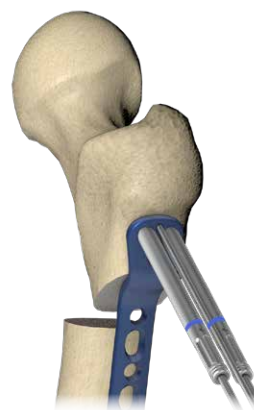

Re-insert the positioning Kirschner wire 2.0/210 [40.4815.210] into the plate hole (it will prevent plate rotation while locking screws insertion).





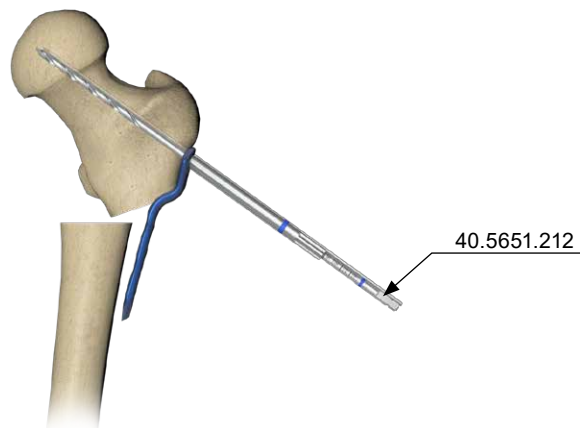
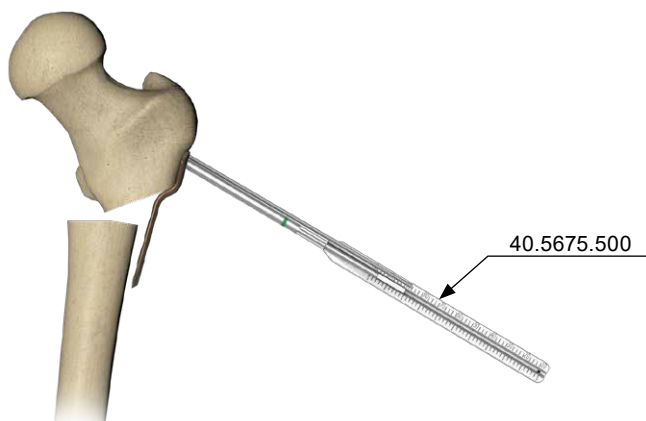

VI.1.8. PLATE STABILIZATION IN EPIPHYSIS PART

VI.1.8.1. Locking screw insertion in holes A and B

	
<p>a) Determine the length of locking screw using screw length measure [40.5675.500].</p>	<p>a) Determine the length of locking screw using drill with scale 4.0/210 [40.5651.212].</p> <ul style="list-style-type: none"> - Remove guide rod 2.8/210 [40.6276.210] and guide sleeve 4.0/2.8 [40.6275.028] from the hole A of the plate. - Drill using drill with scale 4.0/210 [40.5651.212] through guide sleeve 7.0/4.0 [40.6274.040] until the desired depth is reached. <p>NOTE: Drill under the control of X-Ray. Avoid penetration of the growth plate of the femoral head.</p> <ul style="list-style-type: none"> - Read the length of locking screw from the scale on the drill with scale 4.0/210[40.5651.212].



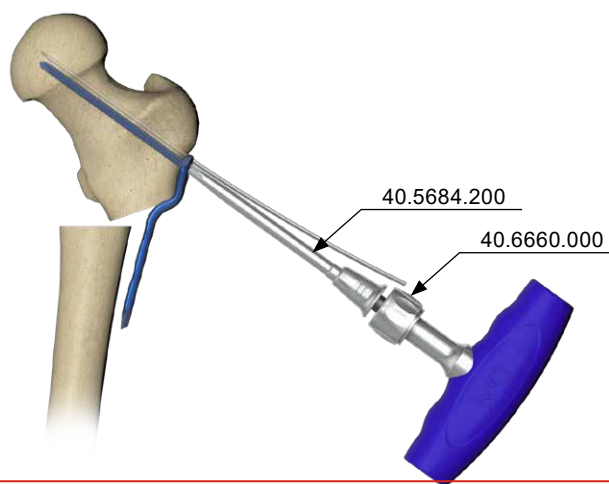
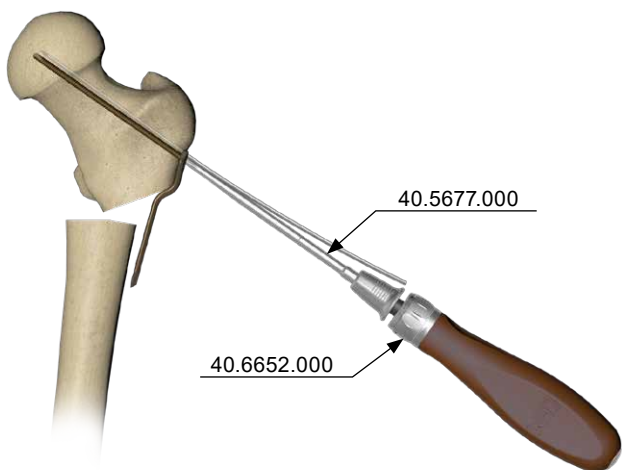

	
b) Remove guide rod 2.8/210 [40.6276.210] from the hole A of the plate.	b) Remove drill with scale 4.0/210 [40.5651.212].
c) Remove guide sleeve 5.0/2.8 [40.6273.028] from the hole A of the plate.	c) Remove guide sleeve 7.0/4.0 [40.6274.040] from the hole A of the plate.
 NOTE: Should it become difficult to remove the sleeve, use appropriate screw-driver tip to facilitate its removal. 	
d) Use torque limiting ratchet handle 2Nm [40.6652.000] and screwdriver tip T15 [40.5677.000] to introduce selected locking screw 5.0ChLP into the plate hole.	d) Use torque limiting ratchet handle 4Nm [40.6660.000] and screwdriver tip T25 [40.5684.200] to introduce selected locking screw 7.0ChLP into the plate hole.



Following the analogous procedure, introduce the locking screw into the hole B of the plate.

Remove positioning Kirschner wire 2.0/210 [40.4815.210].

VI.1.8.2. Locking screw insertion in hole C

	
a) Lock guide sleeve 5.0/2.8 [40.6273.028] in the hole C of the plate.	a) Lock guide sleeve 7.0/4.0 [40.6274.040] in the hole C of the plate.
b) Drill using drill with scale 2.8/210 [40.5653.212] until the desired depth is reached.	b) Drill using drill with scale 4.0/210 [40.5651.212] until the desired depth is reached.
c) Determine the length of the locking screw using the scale of drill with scale 2.8/210 [40.5653.212] or the screw length measure [40.5675.500].	c) Determine the length of the locking screw using the scale of drill with scale 4.0/210 [40.5651.212] or the screw length measure [40.5675.500].

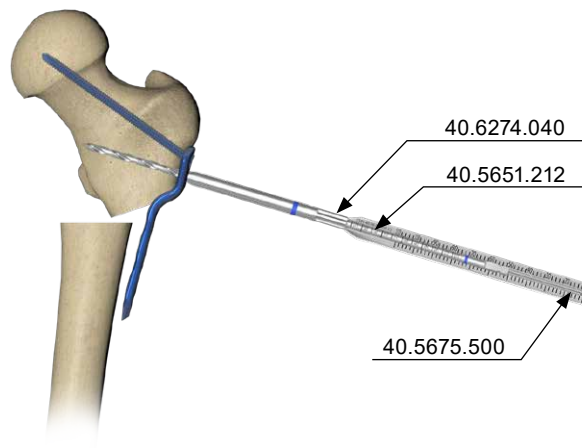
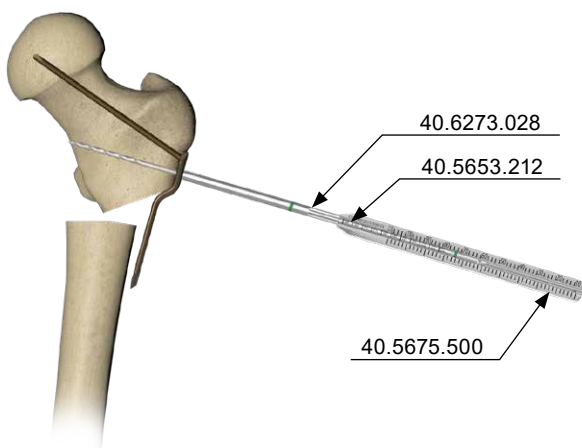

5.0 ChM Locked Plating ChLPsystem	7.0 ChM Locked Plating ChLPsystem
d) Remove drill with scale 2.8/210 [40.5653.212].	d) Remove drill with scale 4.0/210 [40.5651.212].
e) Remove guide sleeve 5.0/2.8 [40.6273.028].	e) Remove guide sleeve 7.0/4.0 [40.6274.040].
f) Use torque limiting ratchet handle 2Nm [40.6652.000] and screwdriver tip T15 [40.5677.000] to introduce selected locking screw 5.0ChLP into the plate hole.	f) Use torque limiting ratchet handle 4Nm [40.6660.000] and screwdriver tip T25 [40.5684.200] to introduce selected locking screw 7.0ChLP into the plate hole.

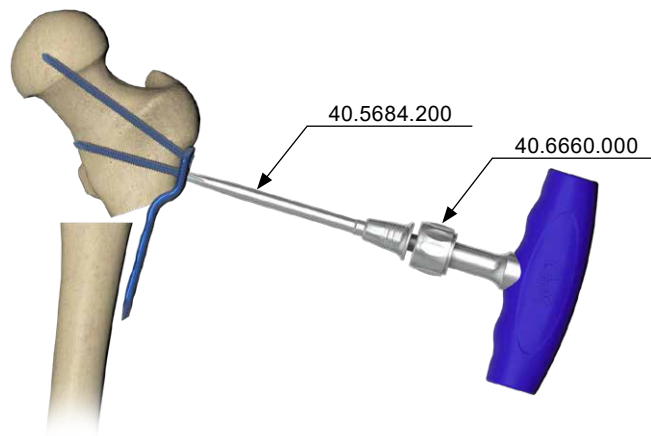
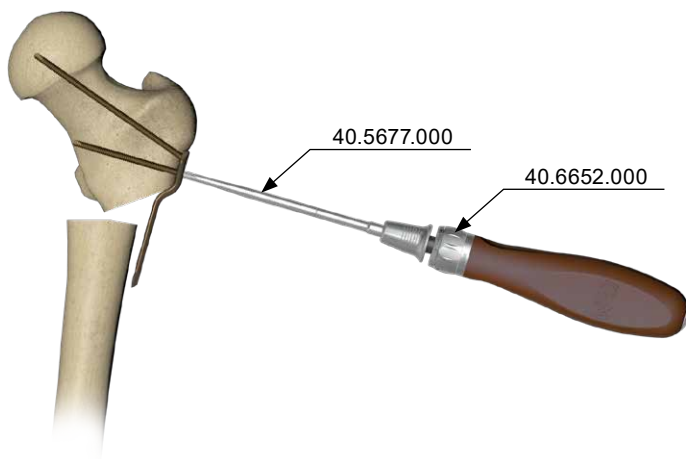

VI.1.9. PLATE STABILIZATION IN THE SHAFT PART



This is a surgeon who decides about the shaft stabilization manner and the screws used: locking or cortical.

VI.1.9.1. Reduction

It is important to perform anatomical reduction and stabilization of the cut bone fragments, before locking in the shaft part of the plate is conducted. Use VERBRUGGE bone holding forceps 9.5x240mm [40.4231.000].



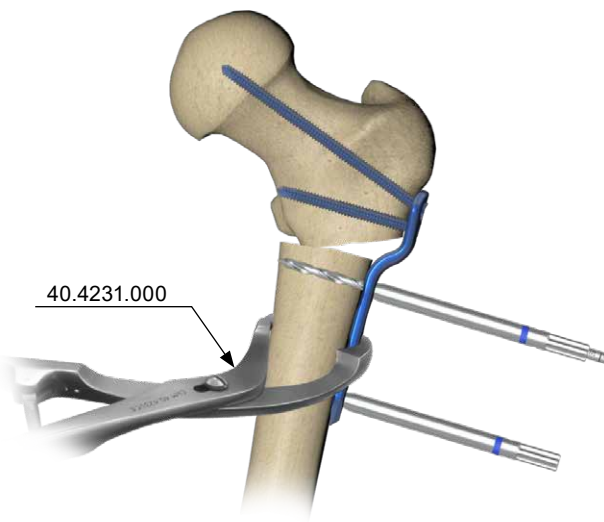

IMPORTANT: make sure bone fragments are thoroughly reduced (plate shaft must adhere to the bone shaft; no axial displacement).



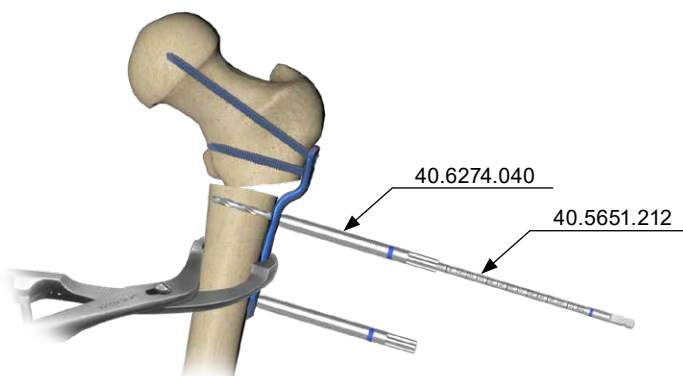
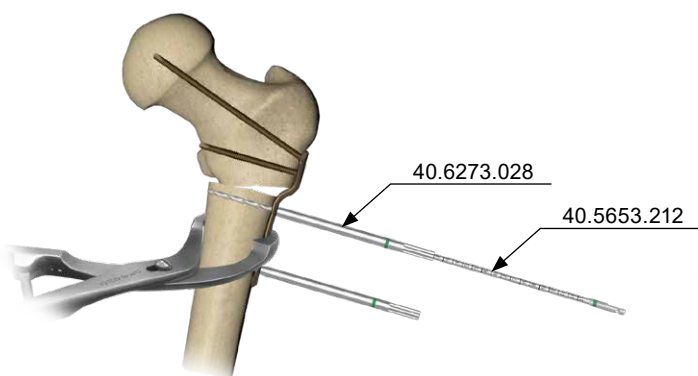

VI.1.9.2. Locking screws insertion

5.0 ChM Locked Plating ChLPsystem	7.0 ChM Locked Plating ChLPsystem
a) Lock guide sleeves 5.0/2.8 [40.6273.028] in the holes 1 and 3 of the plate.	a) Lock guide sleeves 7.0/4.0 [40.6274.040] in the holes 1 and 3 of the plate.
b) Drill using drill with scale 2.8/210 [40.5653.212] until the desired depth of hole 1 is reached.	b) Drill using drill with scale 4.0/210 [40.5651.212] until the desired depth of hole 1 is reached.

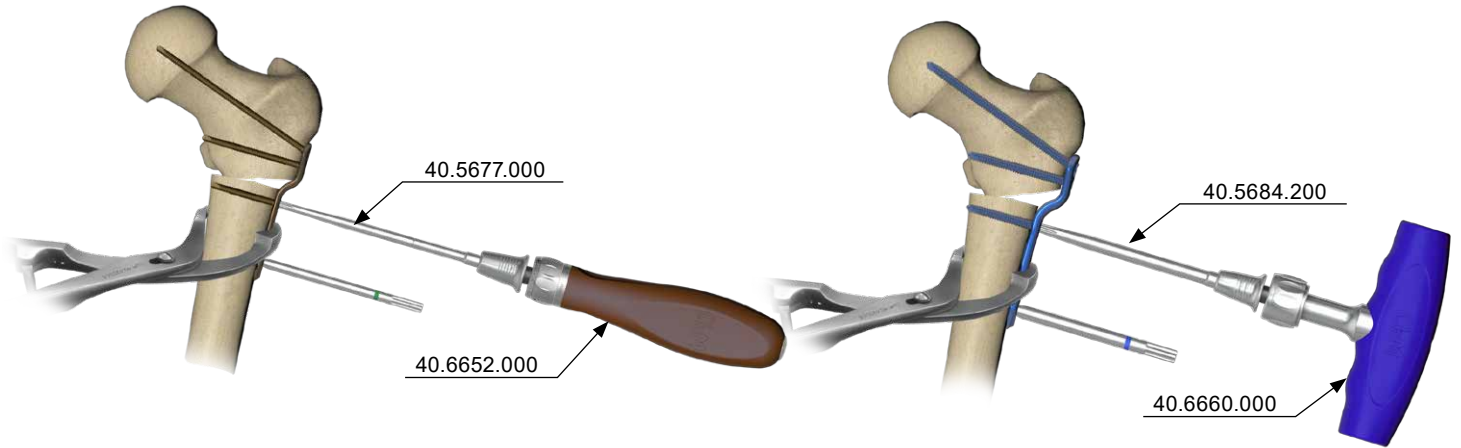

	
c) Determine the length of the locking screw acc. to VI.1.9.2 p. C.	
d) Remove drill with scale 2.8/210 [40.5653.212].	d) Remove drill with scale 4.0/210 [40.5651.212].
e) Remove guide sleeve 5.0/2.8 [40.6273.028].	e) Remove guide sleeve 7.0/4.0 [40.6274.040].
f) Use torque limiting ratchet handle 2Nm [40.6652.000] and screwdriver tip T15 [40.5677.000] to introduce selected locking screw 5.0ChLP into the plate hole.	f) Use torque limiting ratchet handle 4Nm [40.6660.000] and screwdriver tip T25 [40.5684.200] to introduce selected locking screw 7.0ChLP into the plate hole.



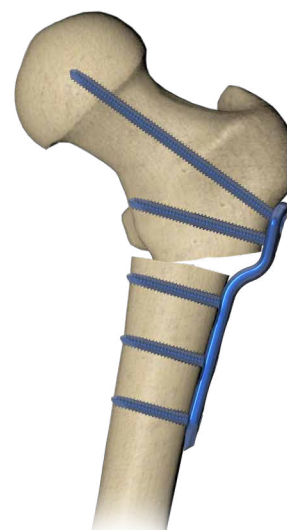

	
g) Following the analogous procedure, introduce the locking screw into the locking hole 2 and 3 of the plate.	g) Following the analogous procedure, introduce the locking screw into the locking hole 2 and 3 of the plate.



VI.1.9.3. Cortical screws insertion

Compression guide positioning

	
Position the compression guide 2.5 [40.4804.025] in a desired position:	Position the compression guide 3.2 [40.4802.732] in a desired position:

a) Neutral Position

Press down the guide to the plate. The guide will set in position that allows neutral insertion of the screw.



b) Compression Position

Move the guide without pressure to the edge of compression hole.
Hole drilled in this position allows for screw insertion in compression position.

c) Angular Position

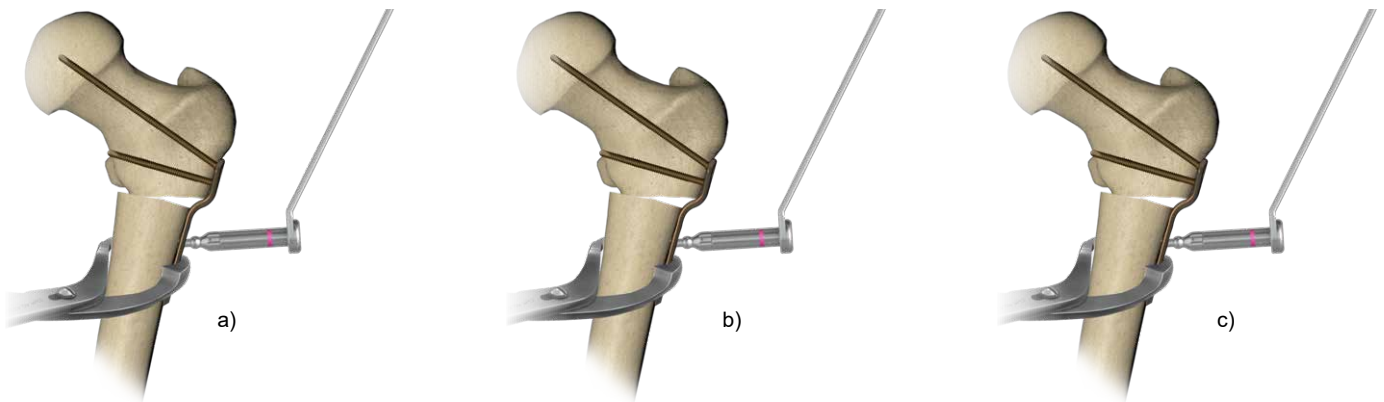
Angular positioning of the guide is also possible.



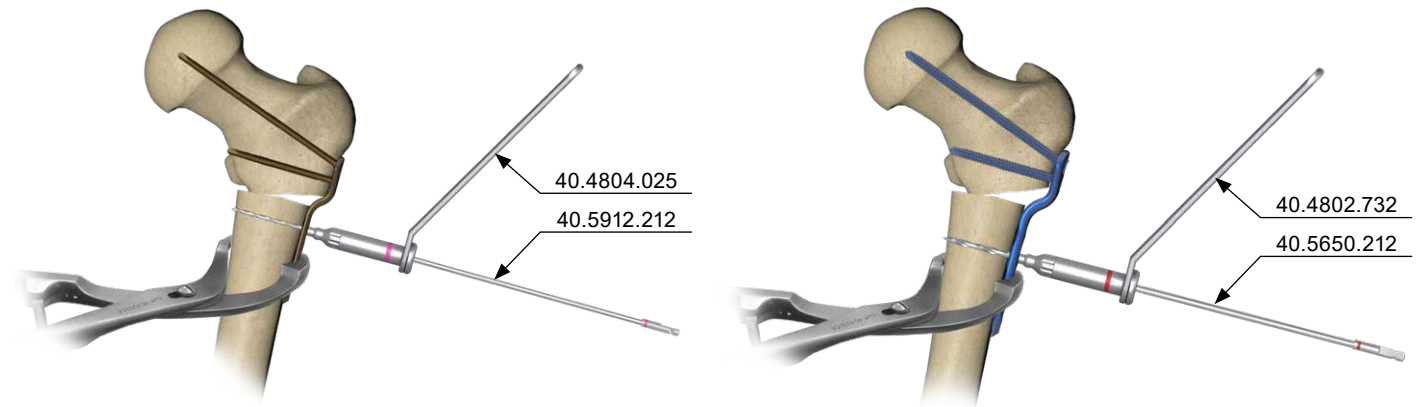

	
a) Using drill with scale 2.5/210 [40.5912.212] drill, in desired position, a hole through both cortices for cortical screw 3.5 insertion.	a) Using drill with scale 3.2/210 [40.5650.212] drill, in desired position, a hole through both cortices for cortical screw 4.5 insertion.

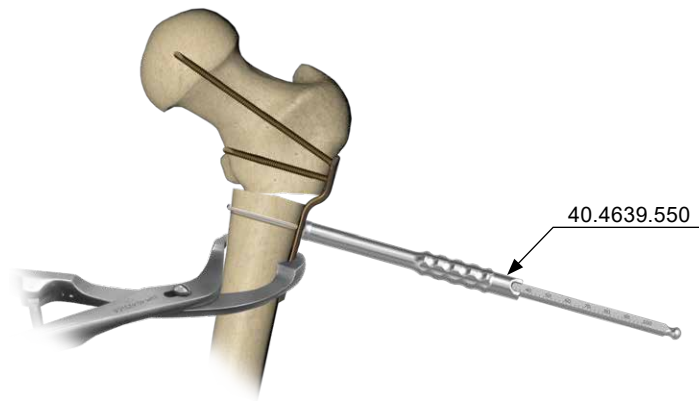

Insert the depth measure [40.4639.550], into drilled hole, until its hook reaches the outer surface of the other cortex bone.



	
<p>b) Insert cortical screw 3.5 of desired length.</p>	<p>b) Insert cortical screw 4.5 of desired length.</p>

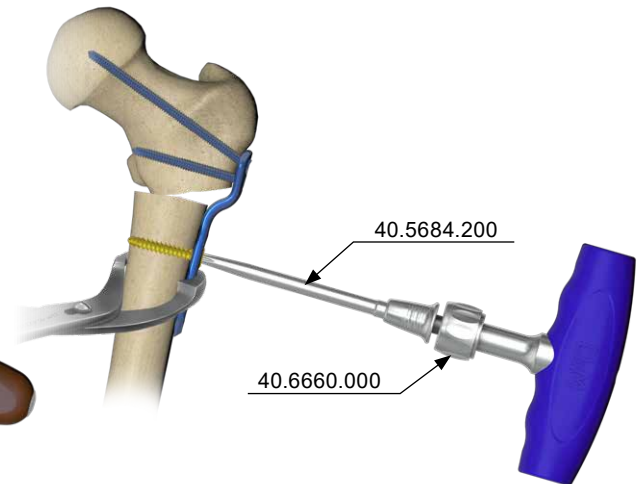
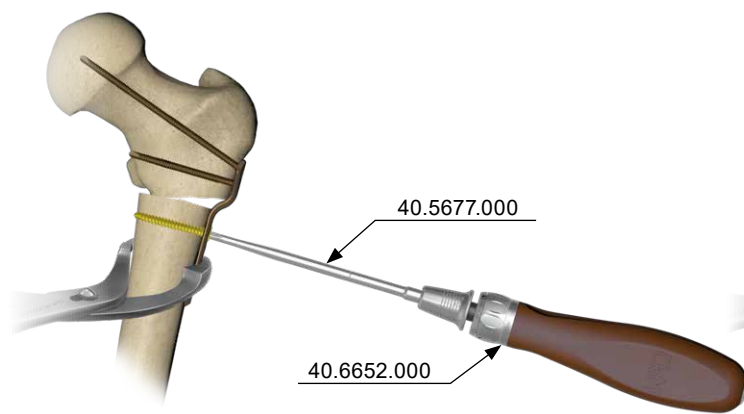



VI.2. MEDIALIZATION

Medialization is used for the distal part of the bone to be medially moved.



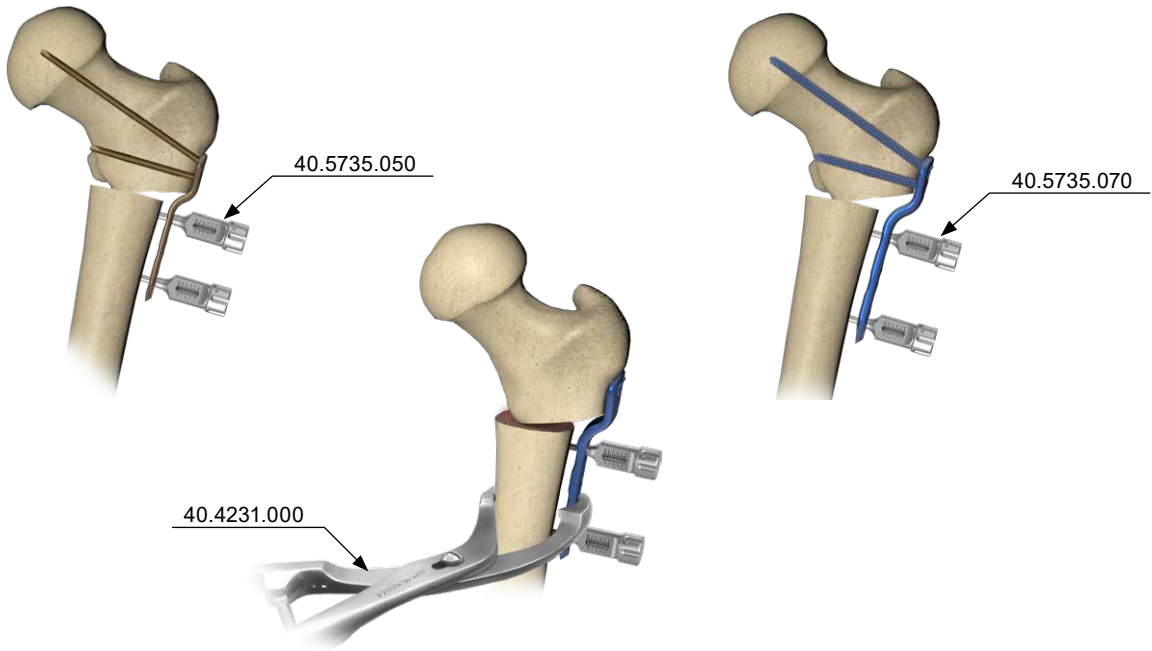

NOTE: Used in varus osteotomy.

	
a) Adjust the desired medialization on the repositors - 5.0ChLP [40.5735.050] using knobs and lock them in the 1 and 3 hole of the locking plate.	a) Adjust the desired medialization on the repositors - 7.0ChLP [40.5735.070] using knobs and lock them in the 1 and 3 hole of the locking plate.





NOTE: Use VERBRUGGE bone holding forceps 9.5x240mm [40.4231.000] for correct bone fragments reduction and stabilization.

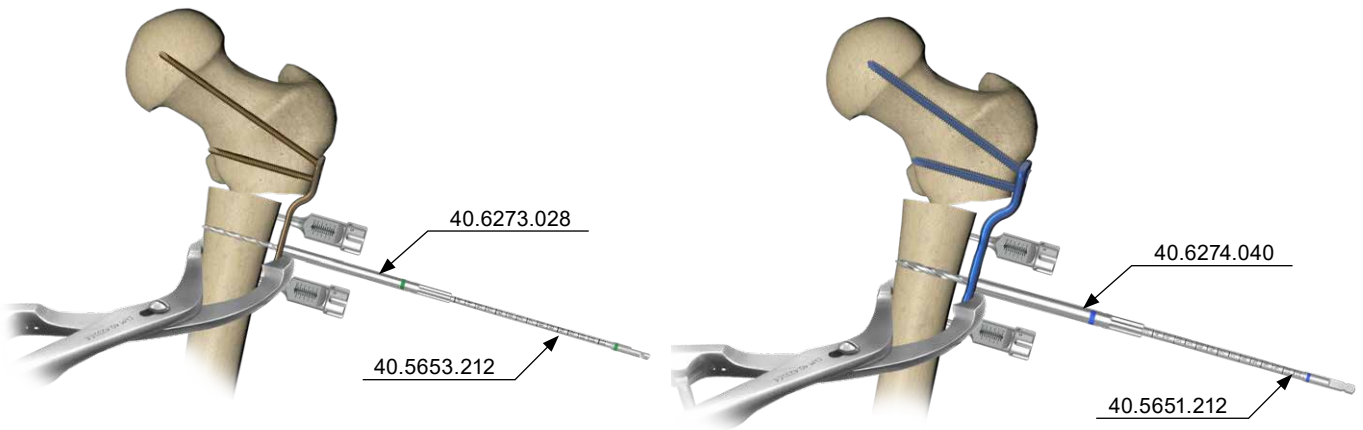

	
b) Lock guide sleeve 5.0/2.8 [40.6273.028] in the hole 2 of the plate.	b) Lock guide sleeve 7.0/4.0 [40.6274.040] in the hole 2 of the plate.
c) Drill using drill with scale 2.8/210 [40.5653.212] until the desired depth is reached.	c) Drill using drill with scale 4.0/210 [40.5651.212] until the desired depth is reached.
d) Determine the length of the locking screw using the scale of drill with scale 2.8/210 [40.5653.212]	d) Determine the length of the locking screw using the scale of drill with scale 4.0/210 [40.5651.212]
or using the screw length measure [40.5675.500].	

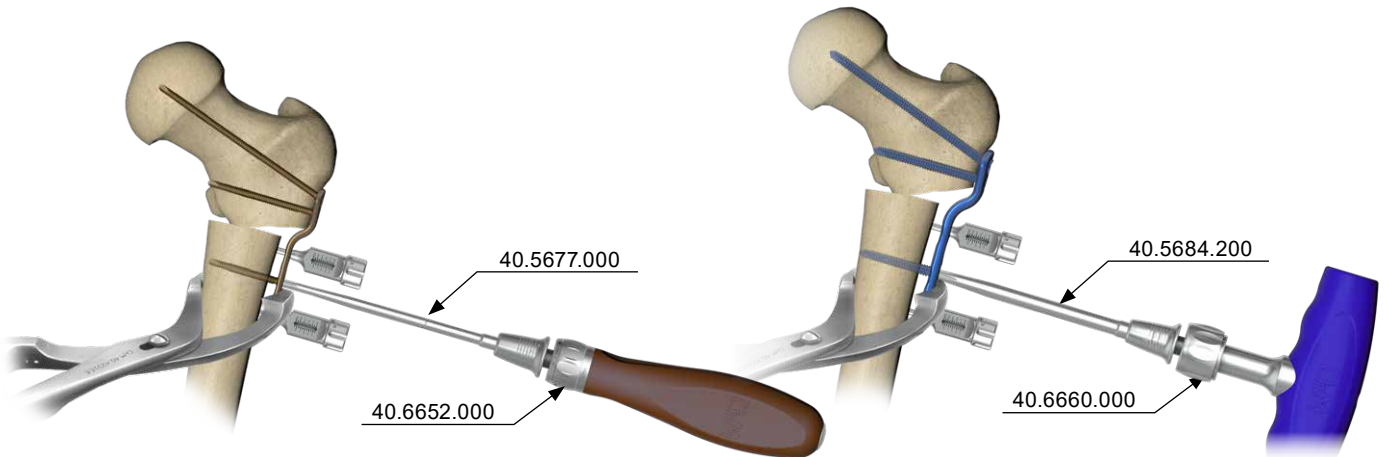

MEDIALIZATION

	
e) Remove drill with scale 2.8/210 [40.5653.212].	e) Remove drill with scale 4.0/210 [40.5651.212].
f) Remove guide sleeve 5.0/2.8 [40.6273.028].	f) Remove guide sleeve 7.0/4.0 [40.6274.040].
g) Use torque limiting ratchet handle 2Nm [40.6652.000] and screwdriver tip T15 [40.5677.000] to introduce selected locking screw 5.0ChLP into the plate hole.	g) Use torque limiting ratchet handle 4Nm [40.6660.000] and screwdriver tip T25 [40.5684.200] to introduce selected locking screw 7.0ChLP into the plate hole.



	
h) Remove reposer - 5.0ChLP [40.5735.050] from hole 1 of the plate. g) Following the analogous procedure, introduce the locking screw into the second hole of the plate.	h) Remove reposer - 7.0ChLP [40.5735.070] from hole 1 of the plate. g) Following the analogous procedure, introduce the locking screw into the second hole of the plate.

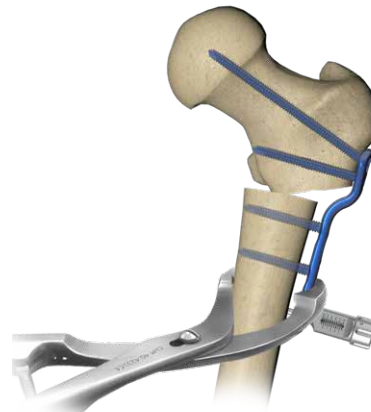
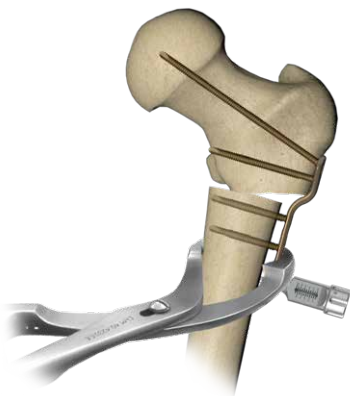

Following the analogous procedure, introduce the locking screw into the third hole of the plate.



VI.3. FRACTURE STABILIZATION

Having performed skin incision and exposure of the fracture site, reduce bone fragments.

Use Kirschner wires to temporary stabilize the fracture.

VI.3.1. KIRSCHNER WIRE INSERTION

Localize the trochanteric epiphysis and introduce Kirschner wire 2.0/210 [40.4815.210] parallel to the axis of the femoral neck (*under X-Ray control*).

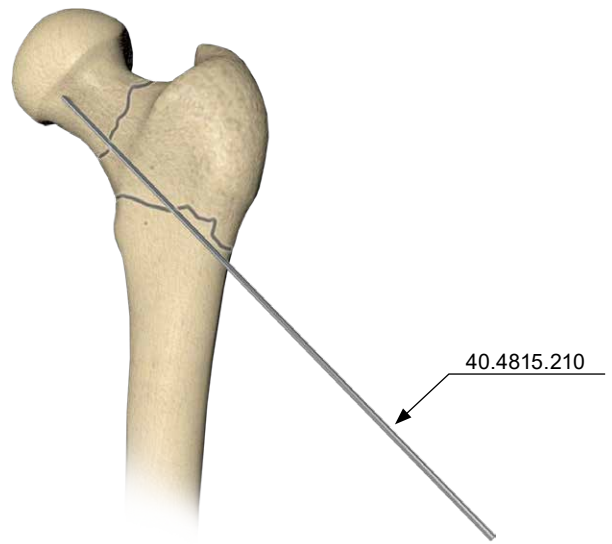

VI.3.2. SETTING OF THE INTRODUCTION ANGLE OF THE POSITIONING KIRSCHNER WIRE

Adjust the introduction angle of the positioning Kirschner wire on the targeter guide [40.5734.000] to 120° and tighten the fixing screw using the guide rod 2.8 connector [40.6277.028].



VI.3.3. POSITIONING KIRSCHNER WIRE INSERTION

Place the targeter guide [40.5734.000] on the femur; the arm of the targeter should be parallel to the Kirschner wire 2.0/210 [40.4815.210].

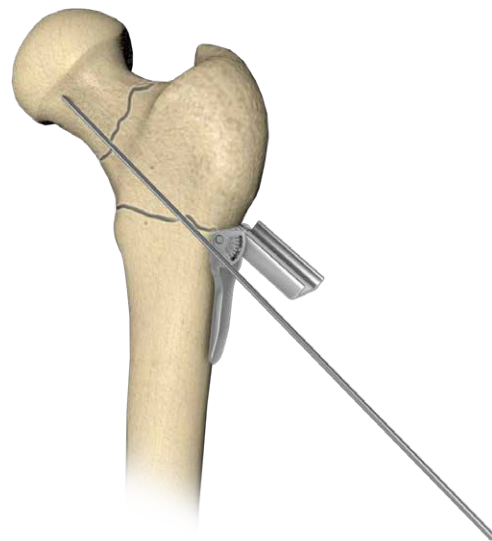

5.0 ChM Locked Plating
ChLPSystem7.0 ChM Locked Plating
ChLPSystem

Insert targeter for trochanteric pediatric plates - 5.0ChLP [40.5733.050].

Insert targeter for trochanteric pediatric plates - 7.0ChLP [40.5733.070].

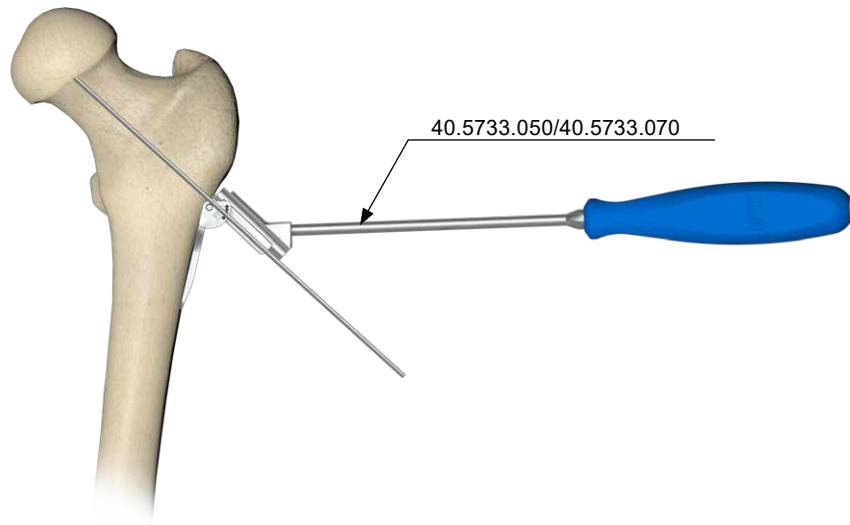

Introduce positioning Kirschner wire 2.0/210 [40.4815.210] through the targeter hole.

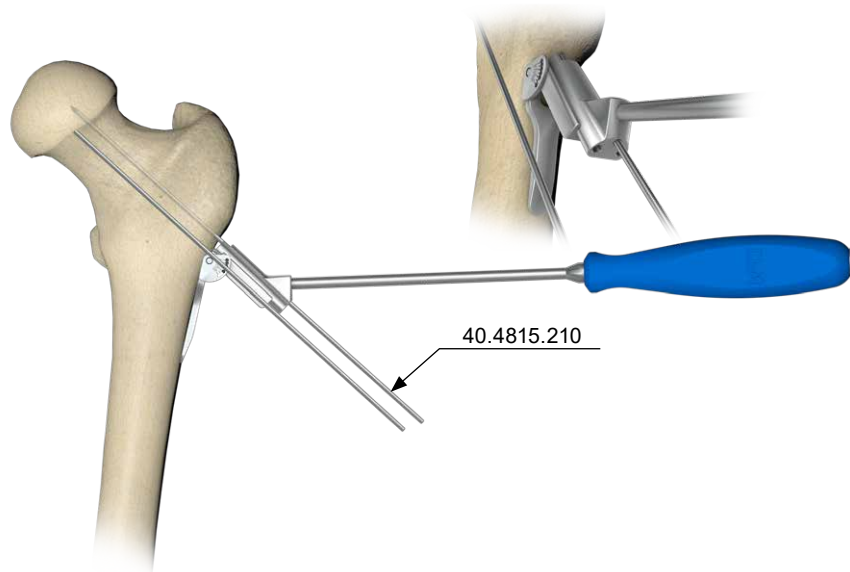

NOTE: The entry point of the positioning Kirschner wire 2.0/210 is located 5-6 mm below the trochanteric epiphysis in the AP projection. Insert the wire acc. to the femoral neck axis in the axial projection, parallel to the Kirschner wire of 2.0/210 [40.4815.210] (under X-Ray control).

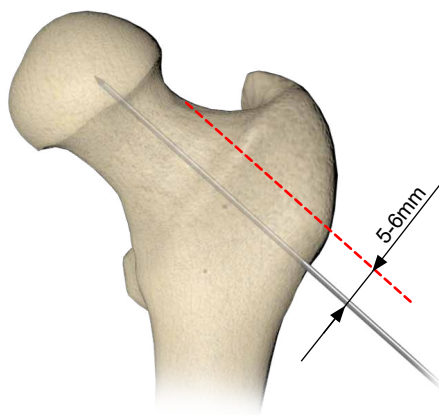

VI.3.4. PLATE GUIDE RODS INSERTION

Introduce two guide rods 2.8/210 [40.6276.210] into holes of the targeter. In order to avoid a collision when inserting guide rods, use guide rod 2.8 connector [40.6277.028].



NOTE: Introduce guide rods into the femoral neck under X-Ray control. Avoid penetration of the growth cartilage of the femoral head!

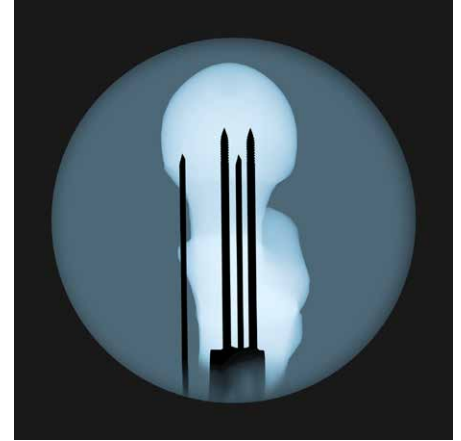
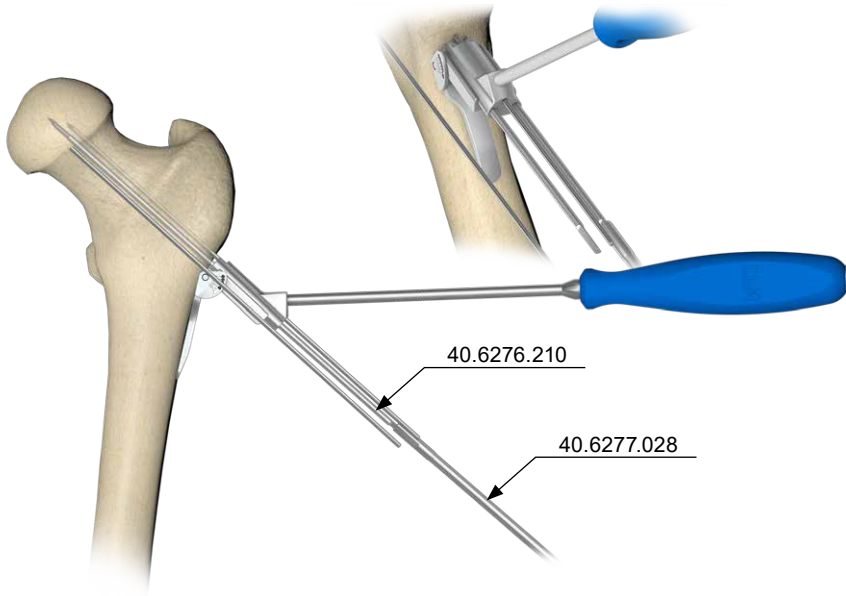

FRACTURE STABILIZATION

VI.3.5. PLATE INSERTION

VI.3.5.1. Guide sleeves insertion

Insert two guide sleeves 5.0/2.8 [40.6273.028] into holes A and B of the plate.	Lock two guide sleeves 4.0/2.8 [40.6275.028] in guide sleeves 7.0/4.0 [40.6274.040] and then insert into holes A and B of the plate.



VI.3.5.2. Plate insertion

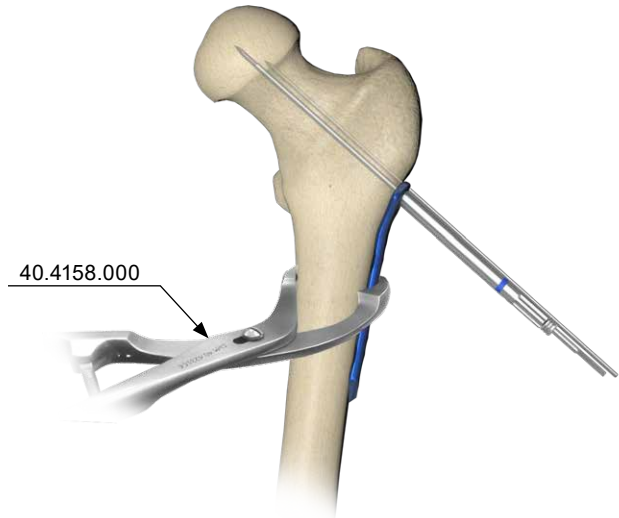

Insert the plate through the guide rods.

Use bone holding forceps 240mm [40.4158.000] for plate stabilization to the bone (plate shaft must adhere to the bone shaft; no axial displacement).





VI.3.6. PLATE STABILIZATION IN EPIPHYSIS PART

VI.3.6.1. Locking screw insertion in holes A and B

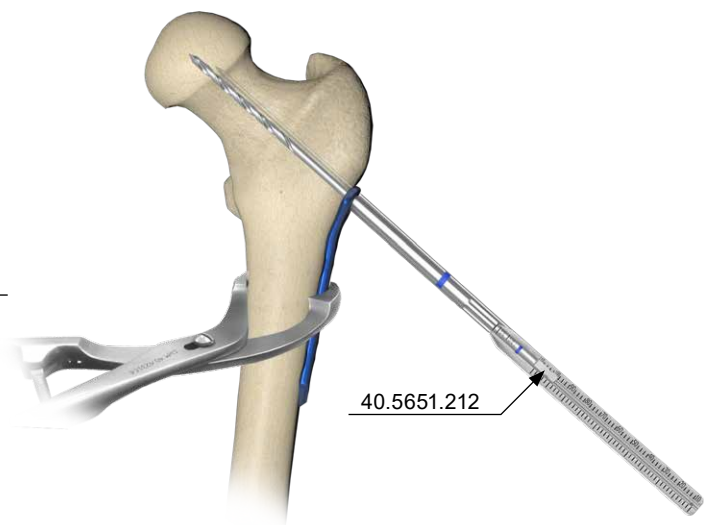
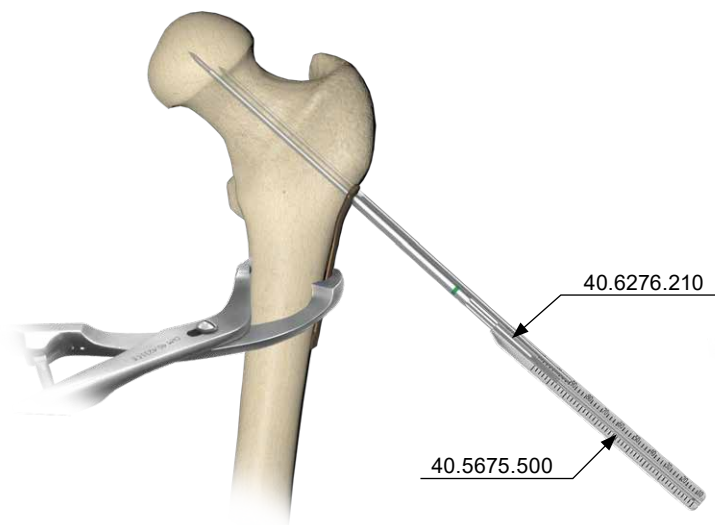
	
<p>a) Determine the length of locking screw using screw length measure [40.5675.500].</p>	<p>a) Determine the length of locking screw using drill with scale 4.0/210 [40.5651.212].</p> <ul style="list-style-type: none"> - Remove guide rod 2.8/210 [40.6276.210] and guide sleeve 4.0/2.8 [40.6275.028] from the hole A of the plate. - Drill using drill with scale 4.0/210 [40.5651.212] through guide sleeve 7.0/4.0 [40.6274.040] until the desired depth is reached. <p>NOTE: Drill under the control of X-Ray. Avoid penetration of the growth plate of the femoral head.</p> <ul style="list-style-type: none"> - Read the length of locking screw from the scale on the drill with scale 4.0/210 [40.5651.212].





	
b) Remove guide rod 2.8/210 [40.6276.210] from the hole A of the plate.	b) Remove drill with scale 4.0/210[40.5651.212].
c) Remove guide sleeve 5.0/2.8 [40.6273.028] from the hole A of the plate.	c) Remove guide sleeve 7.0/4.0 [40.6274.040] from the hole A of the plate.

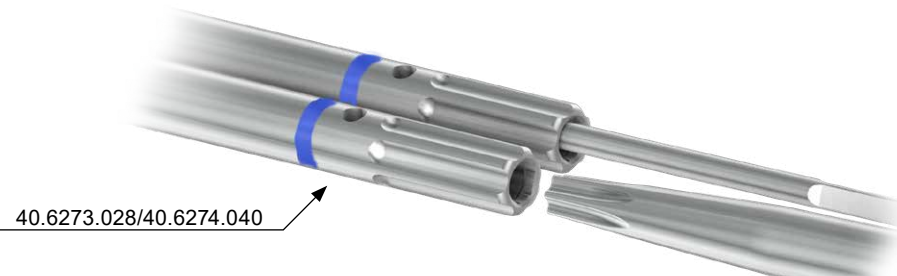

NOTE: Should it become difficult to remove the sleeve, use appropriate screwdriver tip to facilitate its removal.



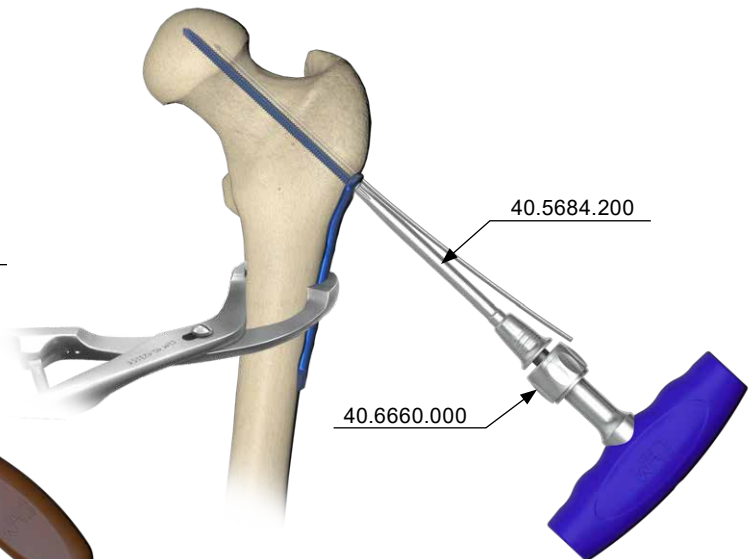
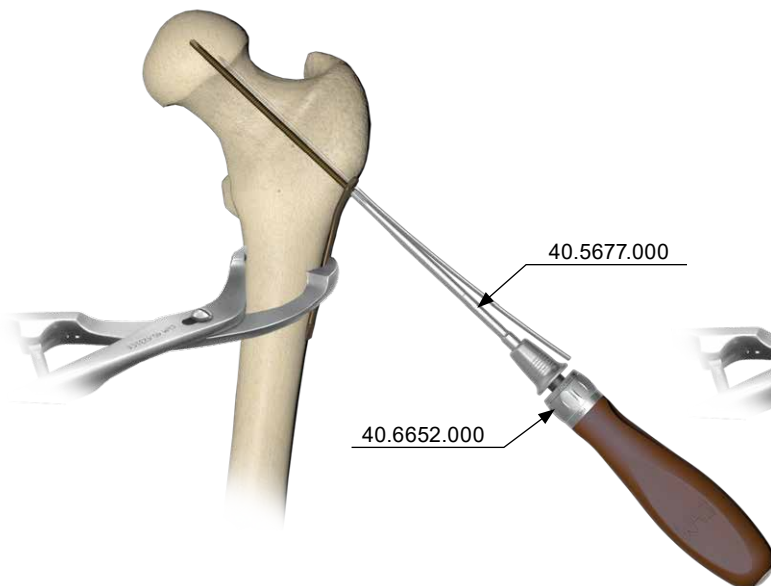

	
d) Use torque limiting ratchet handle 2Nm [40.6652.000] and screwdriver tip T15 [40.5677.000] to introduce selected locking screw 5.0ChLP into the plate hole.	d) Use torque limiting ratchet handle 4Nm [40.6660.000] and screwdriver tip T25 [40.5684.200] to introduce selected locking screw 7.0ChLP into the plate hole.





Following the analogous procedure, introduce the locking screw into the hole B of the plate.

Remove positioning Kirschner wire 2.0/210 [40.4815.210].

VI.3.6.2. Locking screw insertion in hole C

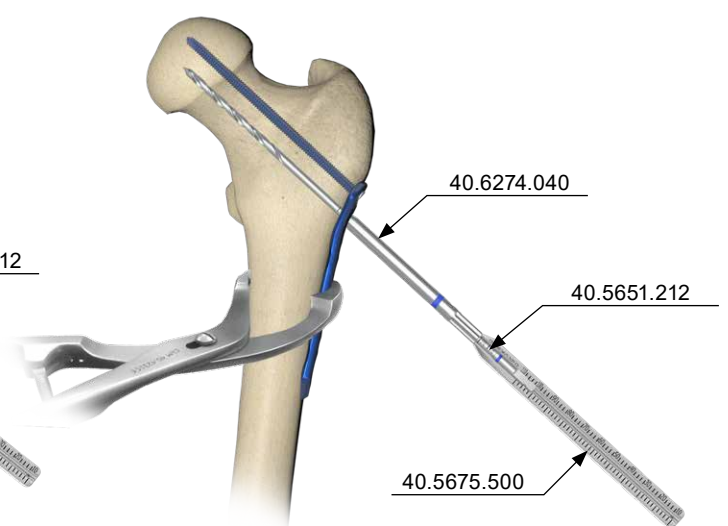
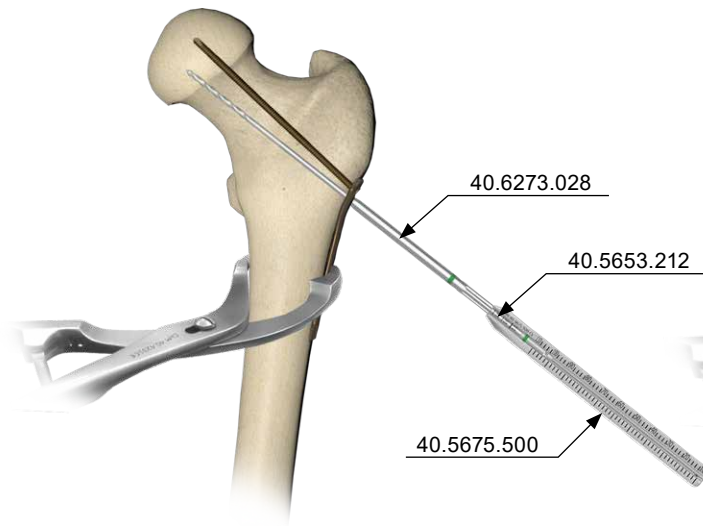
	
a) Lock guide sleeve 5.0/2.8 [40.6273.028] in the hole C of the plate.	a) Lock guide sleeve 7.0/4.0 [40.6274.040] in the hole C of the plate.
b) Drill using drill with scale 2.8/210 [40.5653.212] until the desired depth is reached.	b) Drill using drill with scale 4.0/210 [40.5651.212] until the desired depth is reached.
c) Determine the length of the locking screw using the scale of drill with scale 2.8/210 [40.5653.212] or the screw length measure [40.5675.500].	c) Determine the length of the locking screw using the scale of drill with scale 4.0/210 [40.5651.212] or the screw length measure [40.5675.500].



	
d) Remove drill with scale 2.8/210 [40.5653.212].	d) Remove drill with scale 4.0/210 [40.5651.212].
e) Remove guide sleeve 5.0/2.8 [40.6273.028].	e) Remove guide sleeve 7.0/4.0 [40.6274.040].
f) Use torque limiting ratchet handle 2Nm [40.6652.000] and screwdriver tip T15 [40.5677.000] to introduce selected locking screw 5.0ChLP into the plate hole.	f) Use torque limiting ratchet handle 4Nm [40.6660.000] and screwdriver tip T25 [40.5684.200] to introduce selected locking screw 7.0ChLP into the plate hole.

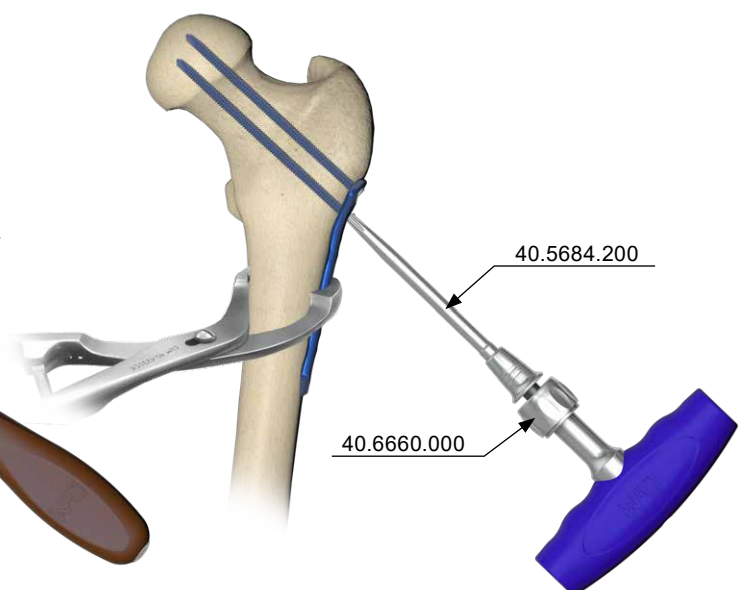
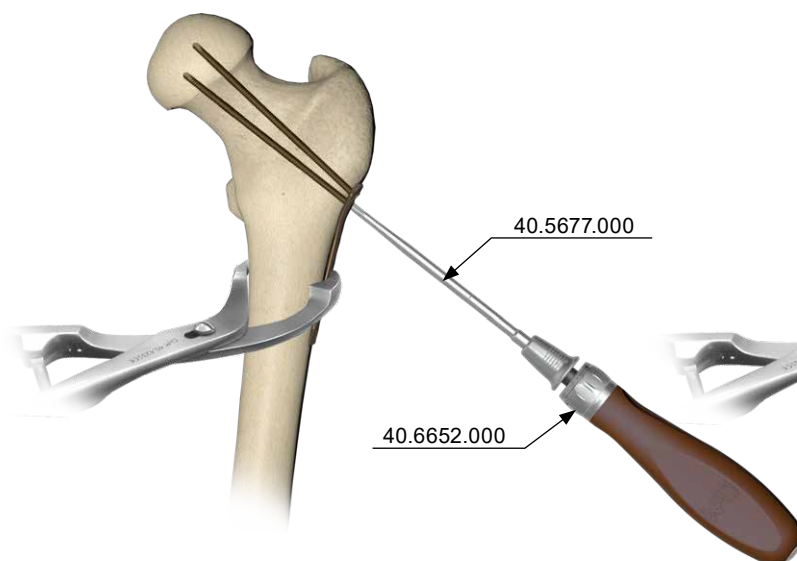

VI.3.7. PLATE STABILIZATION IN THE SHAFT PART



This is a surgeon who decides about the shaft stabilization manner and the screws used: locking or cortical.

VI.3.7.1. Locking screws insertion

a) Lock guide sleeves 5.0/2.8 [40.6273.028] in the holes 1 and 3 of the plate.	a) Lock guide sleeves 7.0/4.0 [40.6274.040] in the holes 1 and 3 of the plate.
b) Drill using drill with scale 2.8/210 [40.5653.212] until the desired depth of hole 1 is reached.	b) Drill using drill with scale 4.0/210 [40.5651.212] until the desired depth of hole 1 is reached.
c) Determine the length of the locking screw using the scale of drill with scale 2.8/210 [40.5653.212] or the screw length measure [40.5675.500].	c) Determine the length of the locking screw using the scale of drill with scale 4.0/210 [40.5651.212] or the screw length measure [40.5675.500].

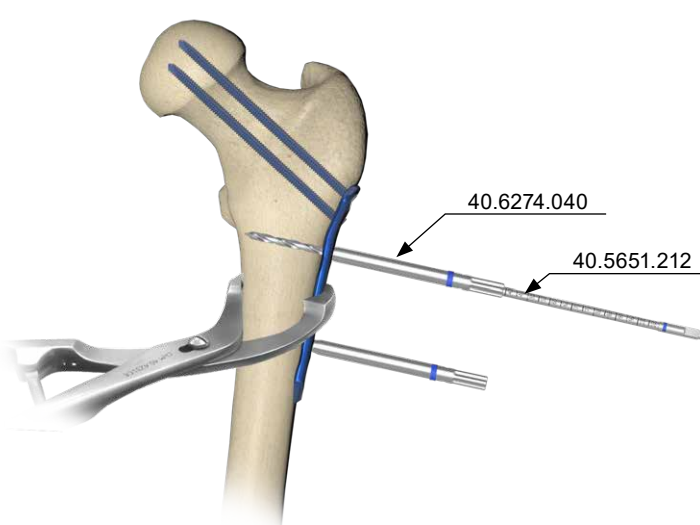
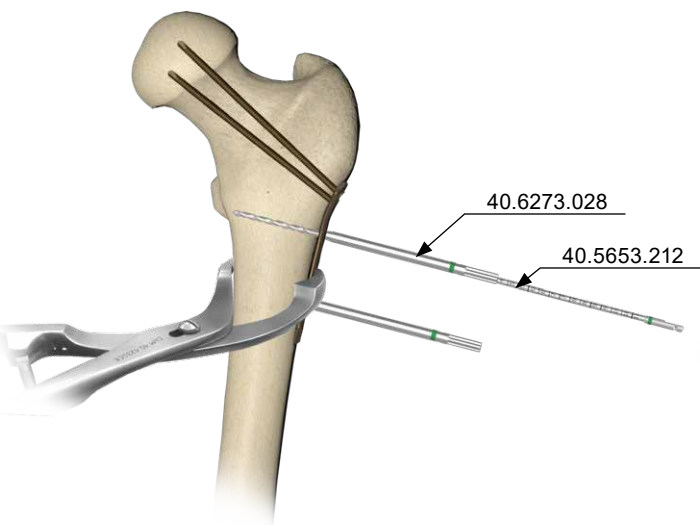

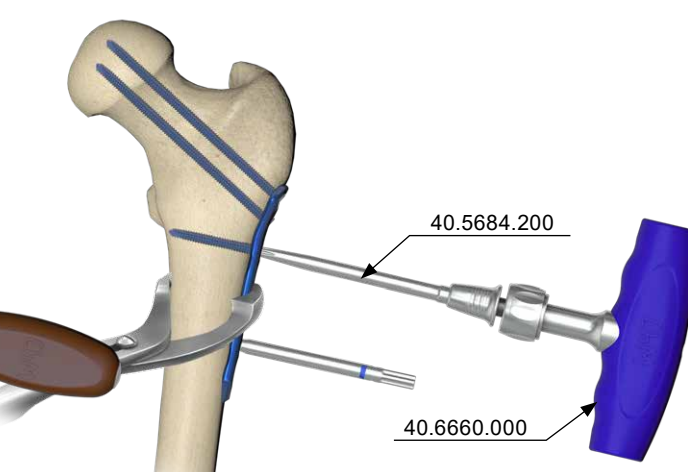
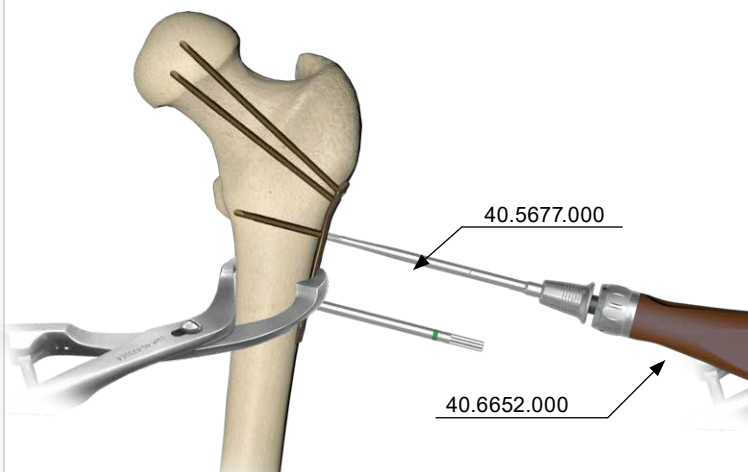

d) Remove drill with scale 2.8/210 [40.5653.212].	d) Remove drill with scale 4.0/210 [40.5651.212].
e) Remove guide sleeve 5.0/2.8 [40.6273.028].	e) Remove guide sleeve 7.0/4.0 [40.6274.040].
f) Use torque limiting ratchet handle 2Nm [40.6652.000] and screwdriver tip T15 [40.5677.000] to introduce selected locking screw 5.0ChLP into the plate hole.	f) Use torque limiting ratchet handle 4Nm [40.6660.000] and screwdriver tip T25 [40.5684.200] to introduce selected locking screw 7.0ChLP into the plate hole.



Following the analogous procedure, introduce the locking screw into the locking hole 2 and 3 of the plate.

VI.3.7.2. Cortical screws insertion

Compression guide positioning

	
Position the compression guide 2.5 [40.4804.025] in a desired position:	Position the compression guide 3.2 [40.4802.732] in a desired position:

a) Neutral Position

Press down the guide to the plate. The guide will set in position that allows neutral insertion of the screw.



b) Compression Position

Move the guide without pressure to the edge of compression hole.
Hole drilled in this position allows for screw insertion in compression position.

c) Angular Position

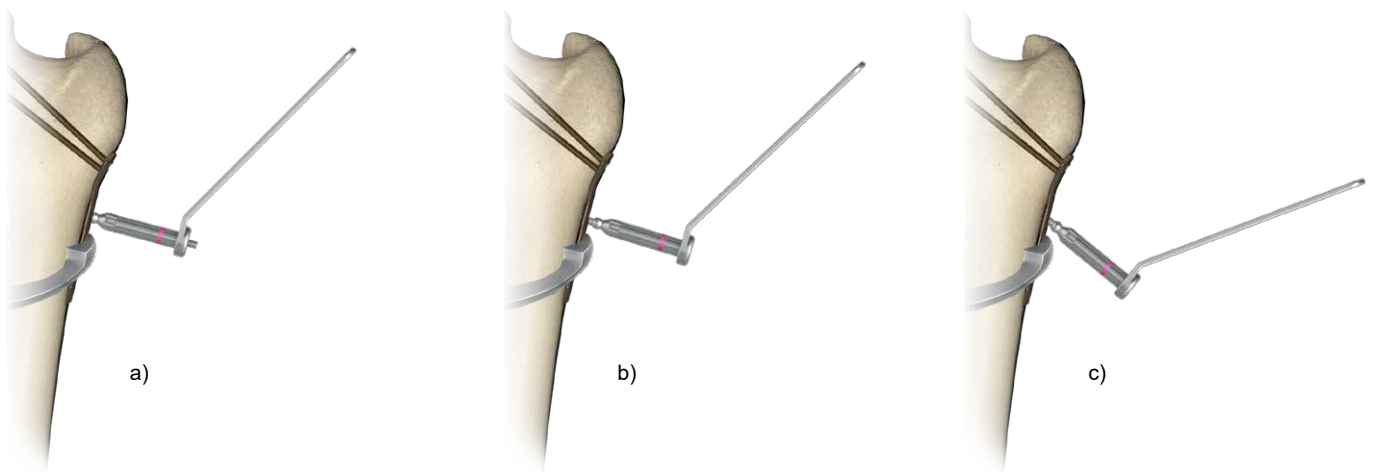
Angular positioning of the guide is also possible.



	
a) Using drill with scale 2.5/210 [40.5912.212] drill, in desired position, a hole through both cortices for cortical screw 3.5 insertion.	a) Using drill with scale 3.2/210 [40.5650.212] drill, in desired position, a hole through both cortices for cortical screw 4.5 insertion.

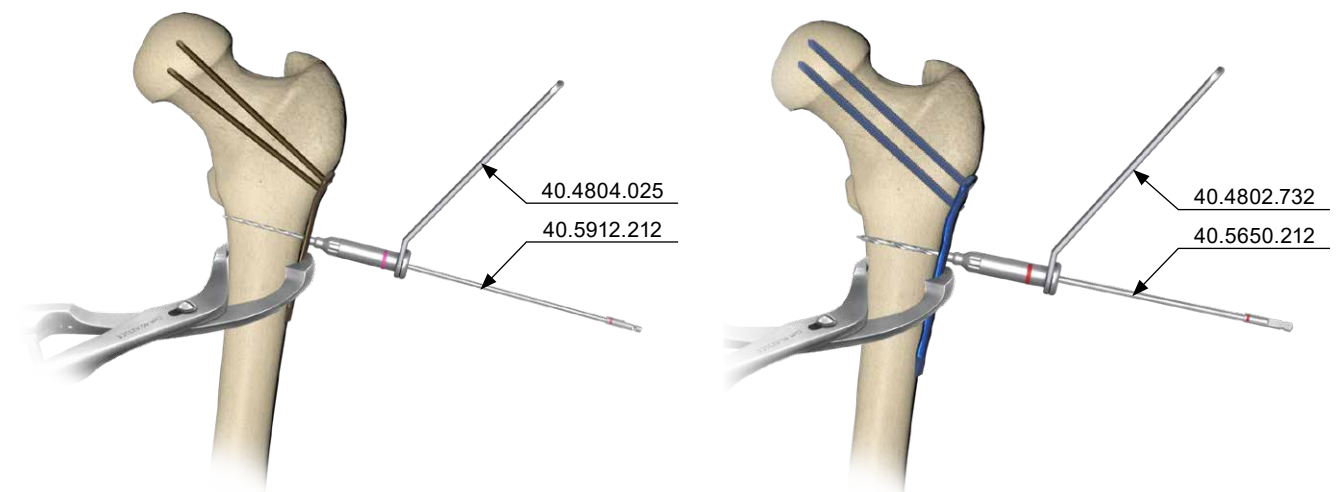

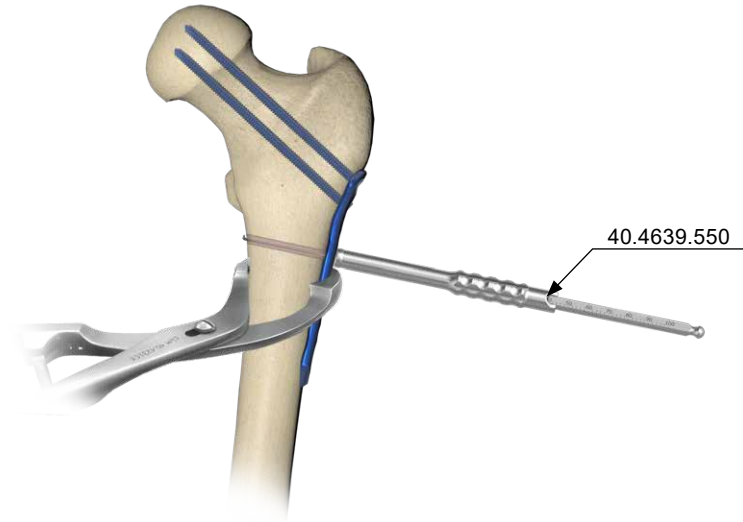

The above description is not detailed instruction of conduct. The surgeon decides about choosing the operating procedure.

Insert the depth measure [40.4639.550], into drilled hole, until its hook reaches the outer surface of the other cortex bone.



FRACTURE STABILIZATION

	
b) Insert cortical screw 3.5 of desired length.	b) Insert cortical screw 4.5 of desired length.

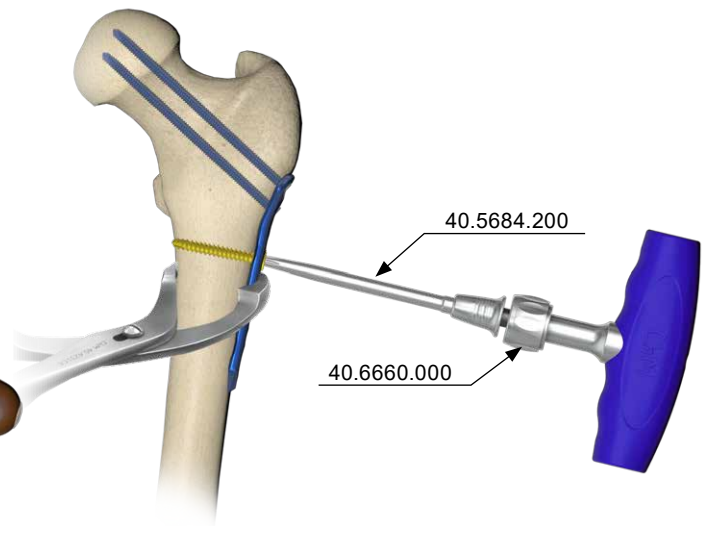
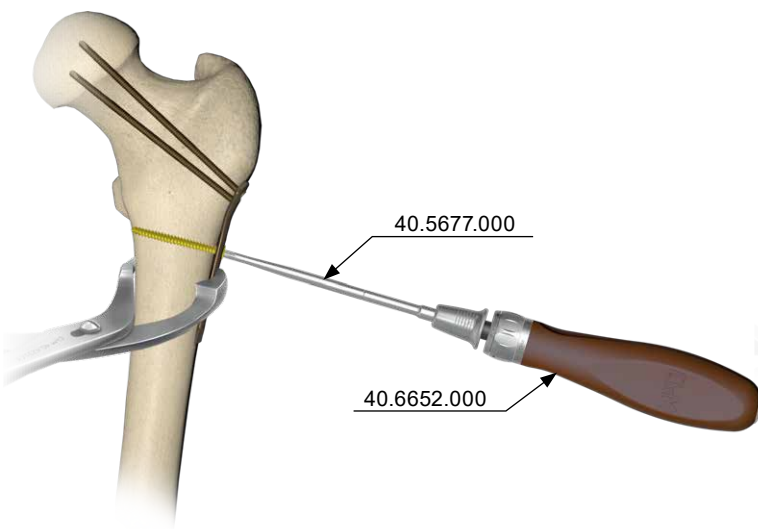

VII. POST-OPERATIVE RECOMMENDATIONS

Introduce proper post-operative treatment. This is the surgeon who decides on post-operative treatment. To avoid restrictions in the hip joint movement, patient's exercises should be introduced as soon as possible after the surgery. However, it is necessary to not overload the limb before the complete fracture union.

VIII. IMPLANT REMOVAL

It is the surgeon who decides about the implant removal. Remember to unlock all locking screws from the plate first and then remove them completely. This will prevent any rotation of the plate when removing the last locking screw.

ChM sp. z o.o.

Lewickie 3b
16-061 Juchnowiec Kościelny
Poland

tel. +48 85 86 86 100

fax +48 85 86 86 101

chm@chm.eu

www.chm.eu



CE 0197