

ChM[®]

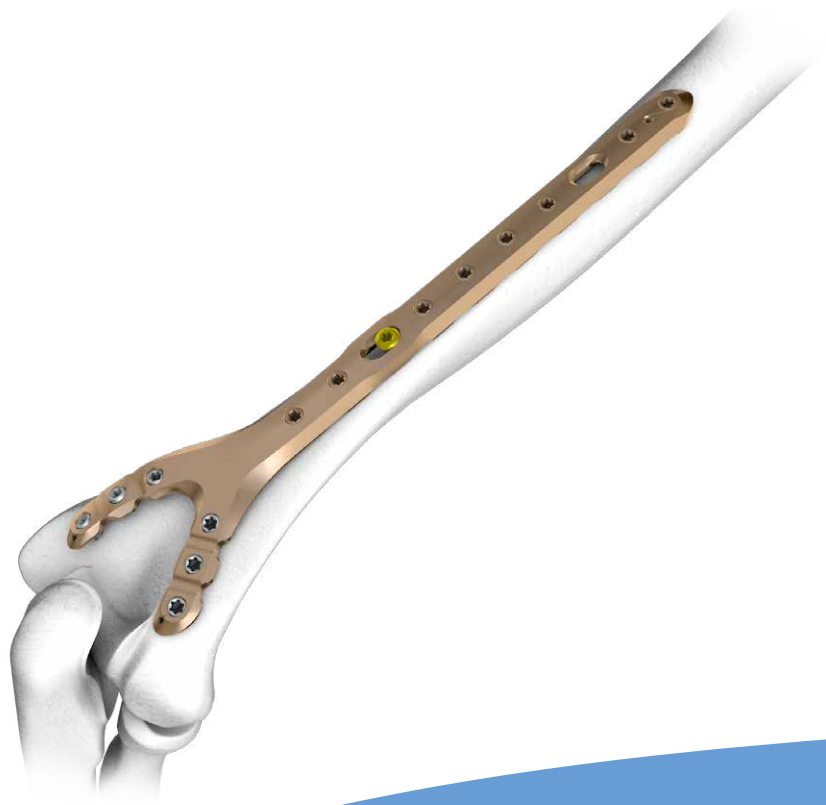



















5.0 ChM Locked Plating
ChLP system

5.0ChLP distal humerus Y plate
3.7243; 3.7244

- *IMPLANTS*
- *INSTRUMENT SET*
- *SURGICAL TECHNIQUE*



SYMBOLS DESCRIPTION

	Titanium or titanium alloy		H length [mm]
	Cobalt		Angle
	Left		available lengths
	Right		Available number of holes
	Available versions: left/right		Thickness [mm]
	Length		Scale 1:1
	Torx drive		Number of threaded holes in the shaft part of the plate
	Torx drive cannulated		Number of locking holes in the plate
	Hexagonal drive		Variable angle
	Hexagonal drive cannulated		Cortical
	Cannulated		Cancellous
	Locking		Available in sterile/ non- sterile condition
	Diameter [mm]		Refer to surgical technique



Caution - pay attention to a special procedure.



Perform the activity under X-Ray control.



Information about the next stages of a procedure.



Proceed to the next stage.



Return to the specified stage and repeat the activity.



Before using the product, carefully read the Instructions for Use. It contains, among others, indications, contraindications, side effects, recommendations and warnings related to the use of the product.



The above description is not a detailed instruction of conduct. The surgeon decides about choosing the operating procedure.

www.chm.eu

Document No ST/80-520
 Date of issue 15.02.2021
 Review date P-001-18.10.2022

The manufacturer reserves the right to introduce design changes.
 Updated INSTRUCTIONS FOR USE are available at the following website: ifu.chm.eu

1. INTRODUCTION	5
2. IMPLANT DESCRIPTION	6
3. SURGICAL TECHNIQUE	8
3.1. PATIENT'S POSITIONING	8
3.2. SURGICAL APPROACH	8
3.3. FRACTURE REDUCTION	8
3.4. Implant selection	8
3.5. PLATE INSERTION	9
3.6. TEMPORARY PLATE STABILIZATION	9
3.7. LOCKING SCREWS INSERTION IN THE EPIPHYSEAL PART OF THE PLATE	9
3.8. CORTICAL SCREWS INSERTION IN THE SHAFT	9
3.9. LOCKING SCREWS INSERTION IN THE SHAFT PART OF THE PLATE	10
3.10. WOUND CLOSURE	10
4. SURGICAL PROCEDURES	11
4a. PROCEDURE OF TEMPORARY IMPLANT STABILIZATION	11
4b. PROCEDURE OF CORTICAL SELF-TAPPING SCREW 3.5 [3.1306] INSERTION	12
4c. PROCEDURE OF 5.0ChLP SELF-TAPPING SCREW 3.5 [3.5200] INSERTION	13
4d. PROCEDURE OF 5.0ChLP SCREW VA 3.5 [4.5236]	14
5. POSTOPERATIVE PROCEDURE	16
6. IMPLANT REMOVAL	16
7. CATALOGUE PAGES	17
7a. INSTRUMENT SET	17
7b. IMPLANTS	19
7c. SCREWS	20

1. INTRODUCTION

This surgical technique applies to 5.0ChLP locked plating system used for stabilization of distal humerus fractures. The plates are a part of the ChLP locked plating system developed by **ChM**. The presented range of implants is made of materials in accordance with ISO 5832 standards.

The system includes:

- implants (*plates and screws*),
- instrument set used during surgery,
- surgical technique.

Indications

- periarticular distal fractures of the humerus,
- distal humerus fractures extended to the shaft,
- corrective osteotomies,
- mal-unions and non-unions.

Plate selection and shaping

The plates are available in various lengths and for left and right limb separately. This allows for optimal selection of the implant to the fracture type. Shaping of the plates is allowed.



Before using the product, carefully read the Instructions for Use. It contains, among others, indications, contraindications, side effects, recommendations and warnings related to the use of the product.



The above description is not a detailed instruction of conduct. The surgeon decides about choosing the operating procedure.

2. IMPLANT DESCRIPTION

Distal humerus Y plates are a part of 5.0ChLP system. This system includes also compatible locking screws. To facilitate their identification, both titanium plate and screws are brown anodized.

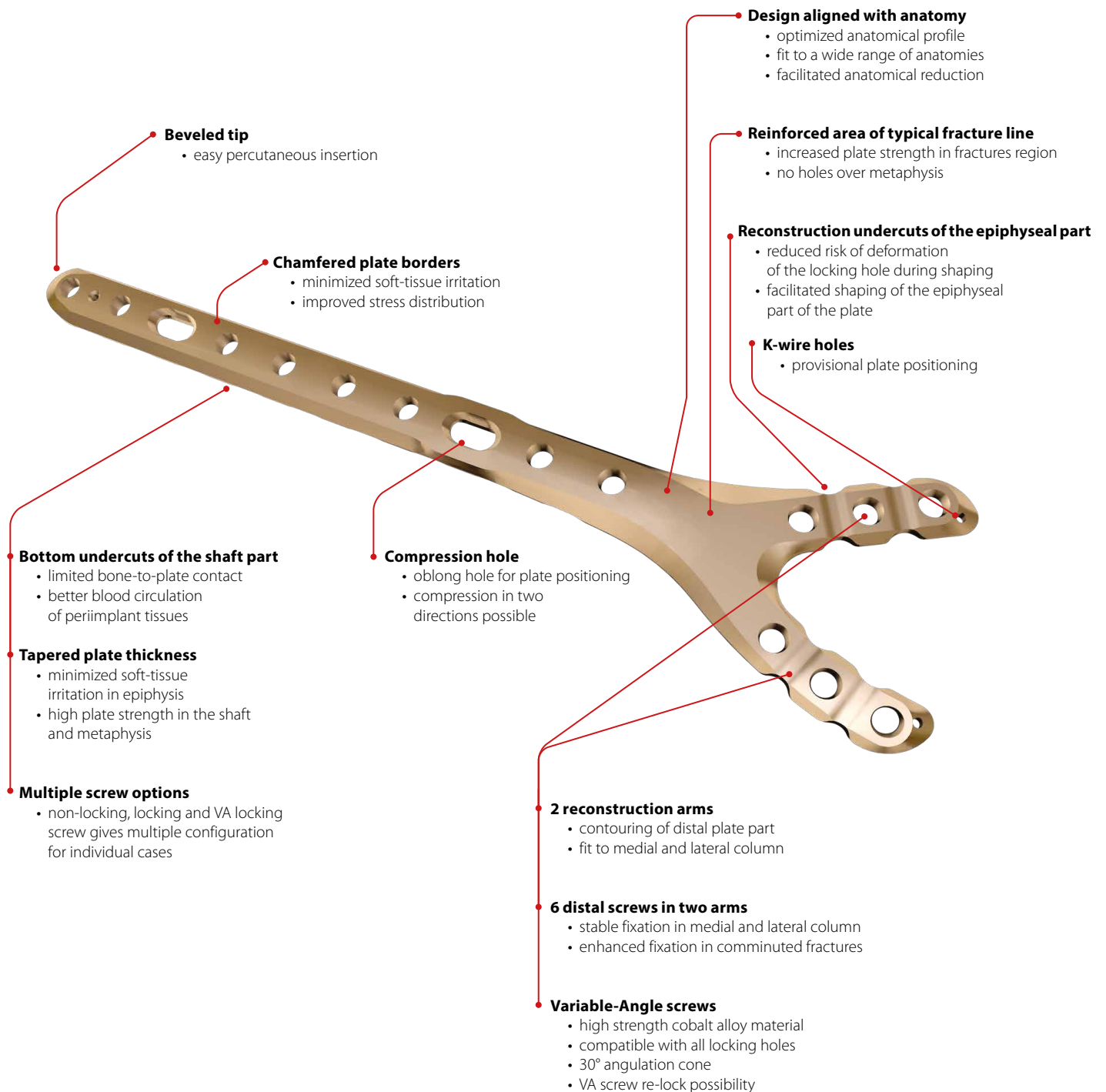

5.0ChLP distal humerus Y plate



3. SURGICAL TECHNIQUE

3.1. PATIENT'S POSITIONING

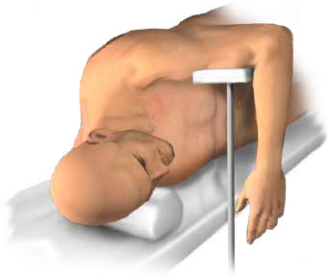

Lateral positioning



Supine positioning

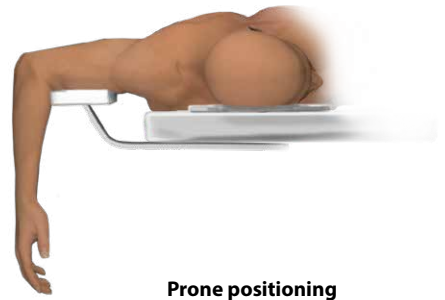

Prone positioning

3.2. SURGICAL APPROACH

Posterior approach

Particular attention should be paid to the ulnar nerve which should be exposed. The posterior approach that bypasses the olecranon, allows for the chevron olecranon osteotomy for better visualization of the fracture site.



3.3. FRACTURE REDUCTION

Perform fracture reduction. If need be, temporarily stabilize the bone fragments with Kirschner wires and/or reduction pliers.

3.4. IMPLANT SELECTION

Select the right size of an implant to the type of fracture, bone size and structure. Use plate trials [\[43.7243.608\]](#)/[\[43.7244.608\]](#) to determine the length of the implant.

Plate 3.7243.608 trial
Plate 3.7244.608 trial



43.7243.608
43.7244.608



3.5. PLATE INSERTION

Position the implant correctly on the bone.

3.6. TEMPORARY PLATE STABILIZATION

Stabilize the position of the implant inserting Kirschner wires into appropriate holes or using setting-compressing screw (*acc. to procedure 4a*).

3.7. LOCKING SCREWS INSERTION IN THE EPIPHYSEAL PART OF THE PLATE

Insert locking screws of a suitable length, into the locking holes of the plate.

- 5.0ChLP self-tapping screw 3.5 **[3.5200]** (*acc. to procedure 4c*).
- 5.0ChLP screw VA 3.5 **[3.5236]** (*acc. to procedure 4d*)

3.8. CORTICAL SCREWS INSERTION IN THE SHAFT

Insert cortical self-tapping screw 3.5 **[3.1306]** into the oval-shaped hole of the plate. If necessary, perform compression (*acc. to procedure 4b*).

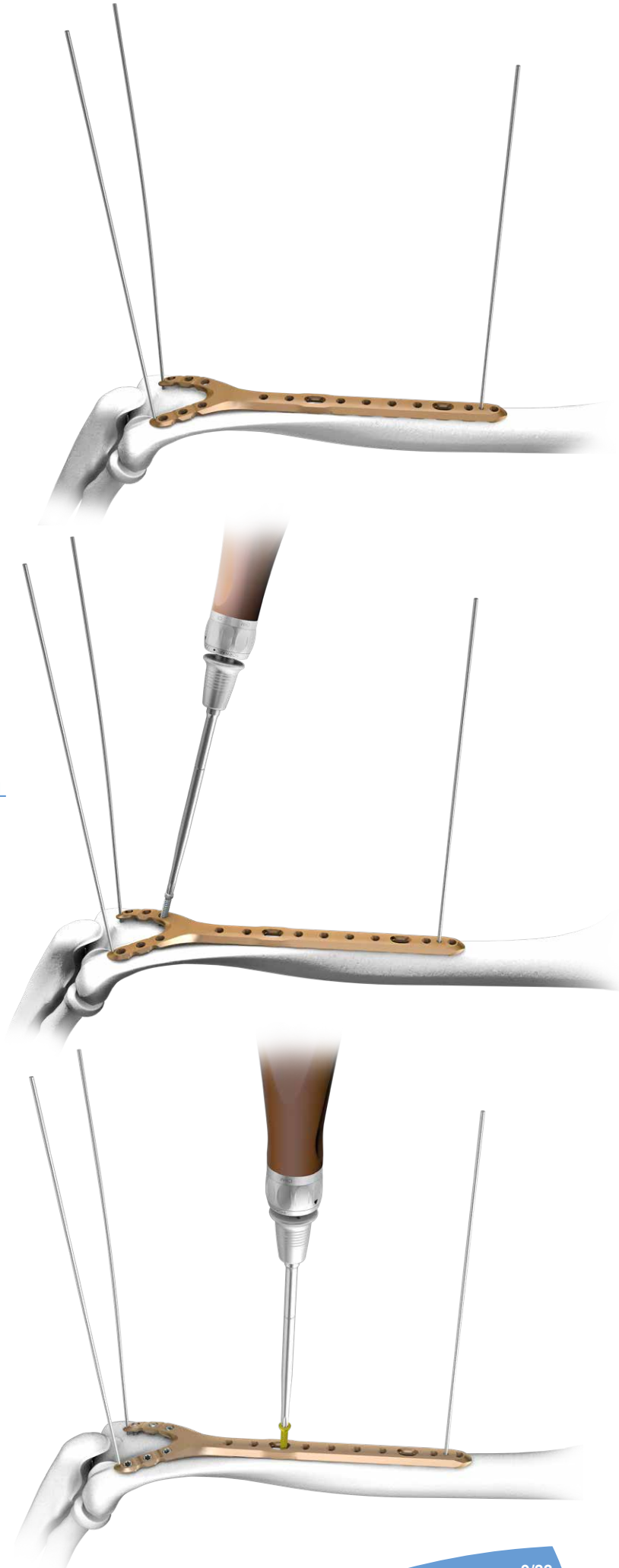

3.9. LOCKING SCREWS INSERTION IN THE SHAFT PART OF THE PLATE

Insert 5.0ChLP self-tapping screw 3.5 **[3.5200]** of a suitable length into the locking holes of the shaft part of the plate (*acc. to procedure 4c*).

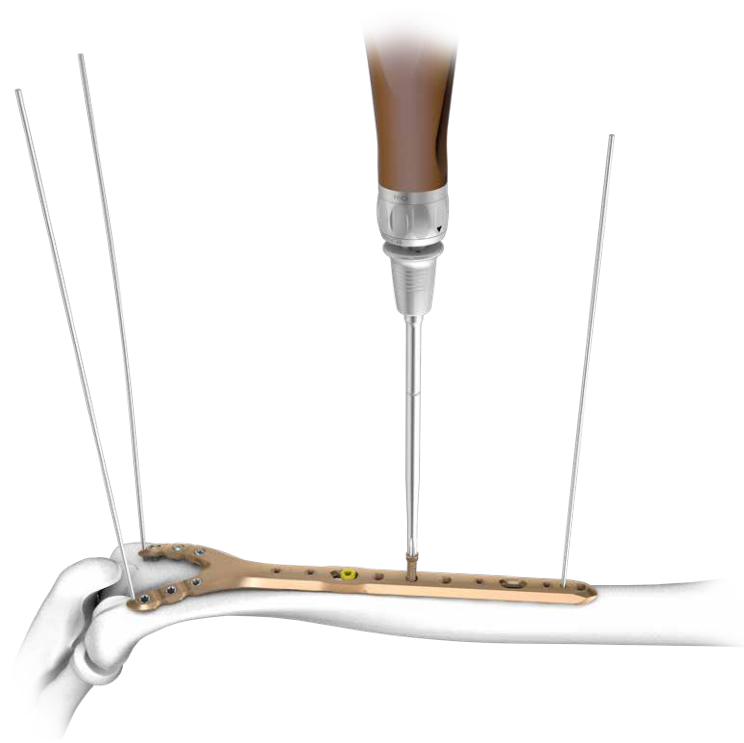

Insert the cortical screws 3.5 into a bone fragment before inserting the locking screws.



The doctor decides about the order and number of locking and cortical screws to be inserted.

3.10. WOUND CLOSURE

Before closing the wound, take an X-Ray image in at least two projections to confirm implant position and fracture reduction. Make sure all the screws are properly tightened and do not penetrate the joint surface. Use appropriate surgical technique to close the wound.



4. SURGICAL PROCEDURES

4a. PROCEDURE OF TEMPORARY IMPLANT STABILIZATION

Stabilization using Kirschner wires

- Stabilize temporary the implant inserting Kirschner wires 1.5/210 [40.4592.210] into dedicated holes in the plate.

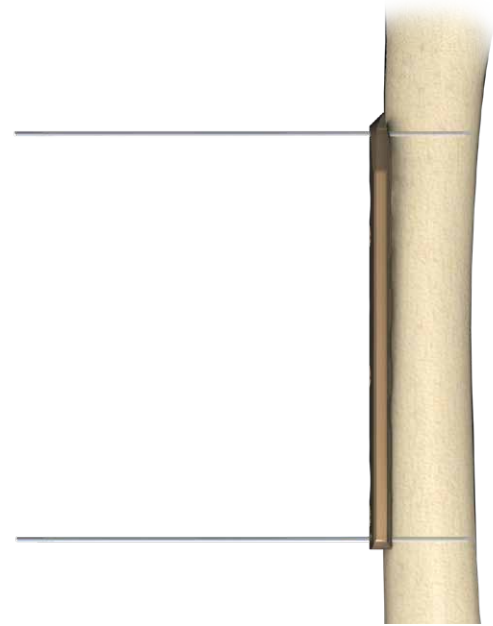

Stabilization in locking holes using Kirschner wires

- Insert guide sleeve 5.0/1.8 [40.5673.718] into the locking hole of the plate.
- Insert Kirschner wire [40.4592.210] through the guide sleeve 5.0/1.8 [40.5673.718].

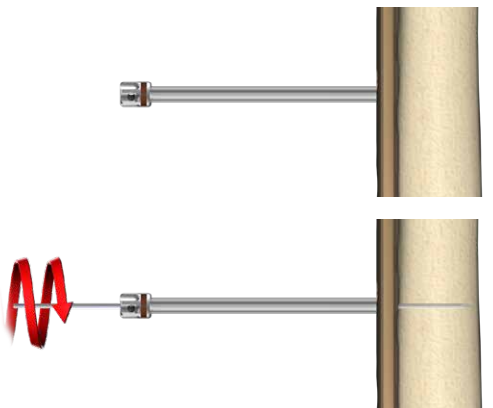
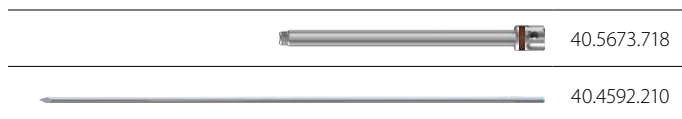

Stabilization using setting-compressing screw

- Insert guide sleeve 5.0/2.8 [40.5673.728] into the locking hole of the plate.
- Insert setting-compressing screw 2.8/180 [40.5674.728] through the guide sleeve 5.0/2.8 [40.5673.728].
- Tighten the nut of the setting-compressing screw [40.5674.728] and push the plate to the bone.

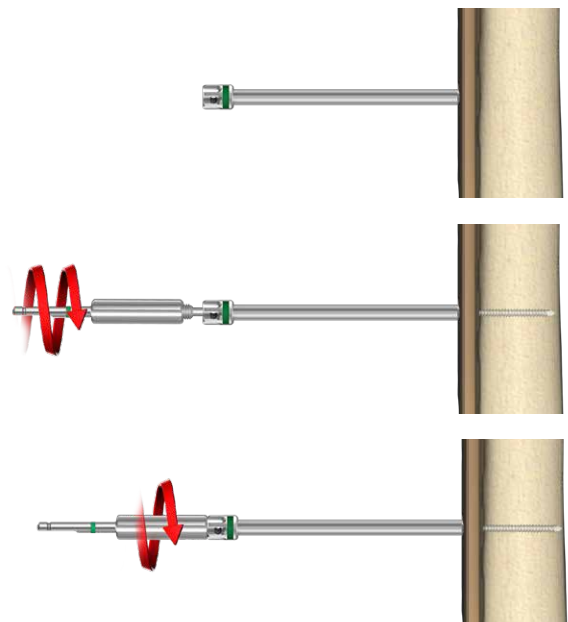
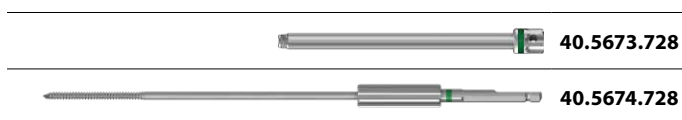

4b. PROCEDURE OF CORTICAL SELF-TAPPING SCREW 3.5 [3.1306] INSERTION

Compression guide positioning

Position the compression guide 2.5 [40.4804.725] in a desired position:



NEUTRAL POSITION: Push the guide to the plate. It will position itself so as neutral insertion of the screw is allowed.

COMPRESSION POSITION: Do not push the guide and move it to the edge of the compression hole. The hole drilled in this position allows compressive insertion of the screw.

ANGULAR POSITION: Angular position of the guide may also be applied.

NEUTRAL POSITION



COMPRESSION POSITION

ANGULAR POSITION

Hole drilling

Perform a hole through both cortices for a cortical screw 3.5 insertion. For drilling, use drill with scale 2.5/210 [40.5912.212] and compression guide in a desired position.



Measurement of hole depth

Insert depth measure [40.4639.550] into drilled hole until the hook of the measure rests against the outer surface of the second cortex.



Screw insertion

Insert cortical screw using handle ratchet device [40.6654.000] and screwdriver tip T15 [40.5677.000].

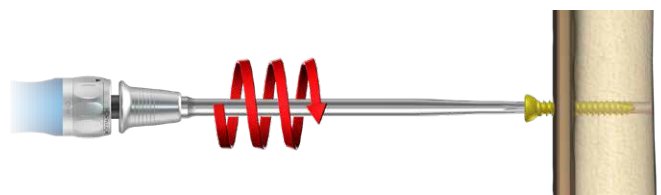
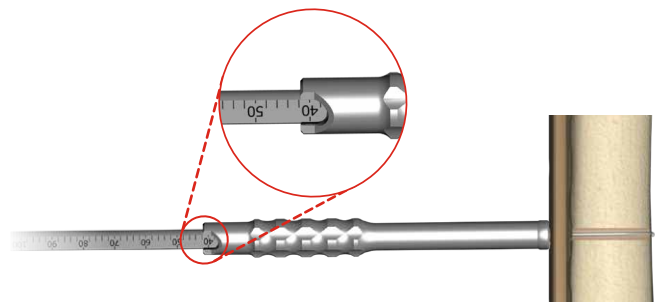
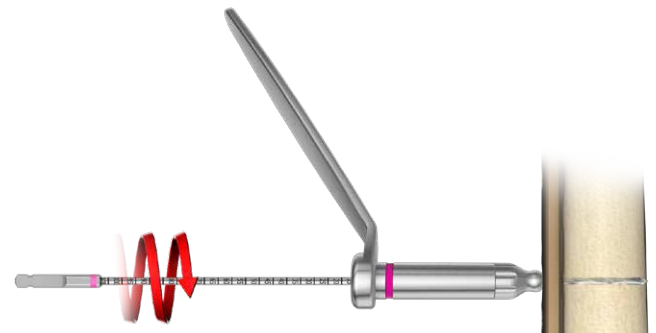

4c. PROCEDURE OF 5.0ChLP SELF-TAPPING SCREW 3.5 [3.5200] INSERTION

Guide sleeve insertion

- Insert guide sleeve 5.0/2.8 [40.5673.728] into a locking hole of the plate.



40.5673.728

Hole drilling

Drill using drill with scale 2.8/210 [40.5653.212] until desired depth is reached.



40.5653.212

Measurement of hole depth

OPTION I: Read the length of the screw from the drill measure [40.5653.212]



40.5653.212

OPTION II: or use screw length measure [40.5675.500].



40.5675.500

OPTION III: Having removed the guide sleeve 5.0/2.8 [40.5673.728], use depth measure [40.4639.550] to determine the length of a screw.



40.4639.550

Screw insertion

Remove the guide sleeve 5.0/2.8 [40.5673.728]. Use torque limiting ratchet handle 2Nm [40.6652.000] and screwdriver tip T15 [40.5677.000] to insert the locking screw.



40.6652.000



40.5677.000



The final tightening of the locking screw, especially when a drive is used, should always be performed with the use of torque limiting handle. Failure to use the torque limiting handle may lead to intraoperative and postoperative complications (*during later removal of the plate and locking screws*).

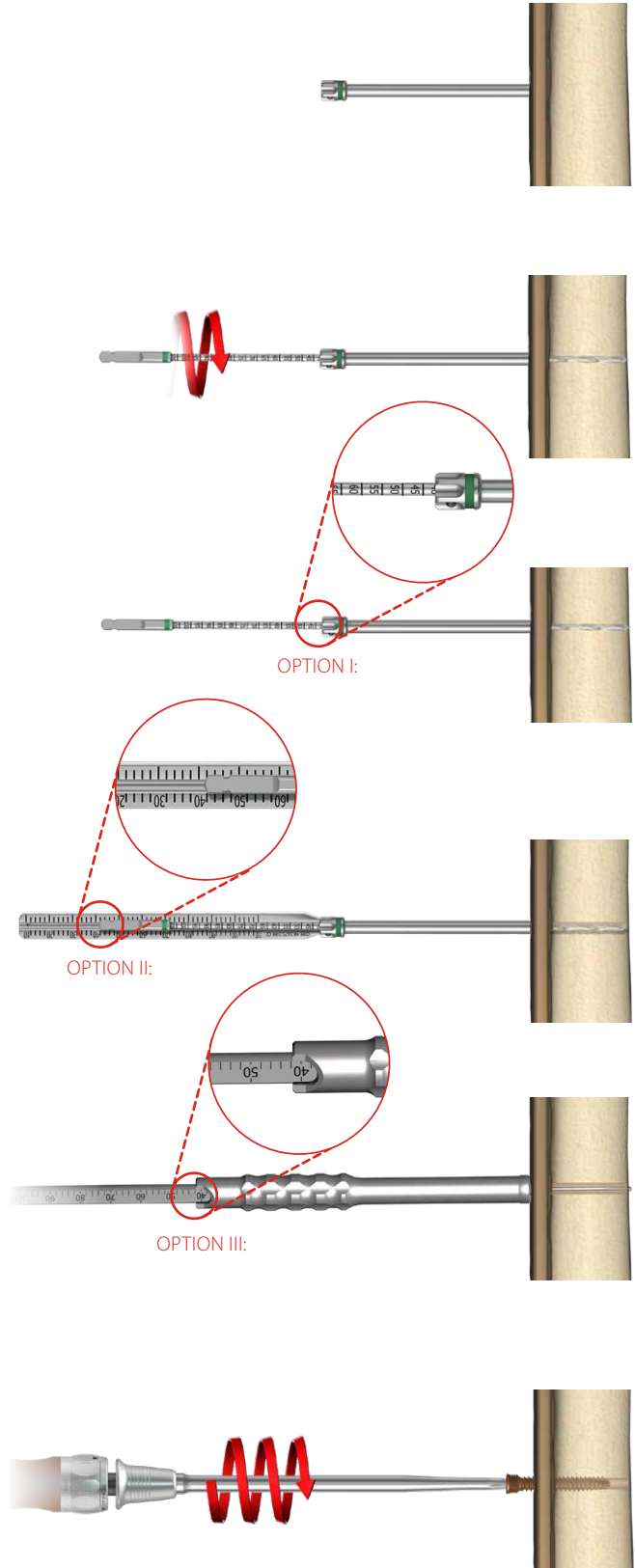

4d. PROCEDURE OF 5.0ChLP SCREW VA 3.5 [4.5236]



When using variable angle (VA) screws, there is a risk of collision of screws or a drill with already implanted screws. Well-thought-out trajectory of inserted screws and intraoperative X-Ray control of drilling reduces the risk of the collision.

Guide VA positioning

- Insert the guide VA 2.8 [40.8206.028] into the locking hole co-axially.
- Set the desired inclination of the guide in relation to the locking hole axis. The guide enables the inclination of 15° in each direction with respect to the axis of the locking hole.



40.8206.028



Exceeding the inclination angle of more than 15° may prevent proper locking of the VA screw in the plate hole.

Hole drilling

- Drill using drill with scale 2.8/210 [40.5653.212] until desired depth is reached.



40.5653.212



Drill under X-Ray control to avoid a collision of the drill with already implanted screws.

Measurement of hole depth

OPTION I: Read the length of the screw from the drill measure [40.5653.212].



40.5653.212

OPTION II: or use screw length measure [40.5675.500].



40.5675.500

OPTION III: Having removed the guide VA, use depth measure [40.4639.550] to determine the length of the screw.



40.4639.550

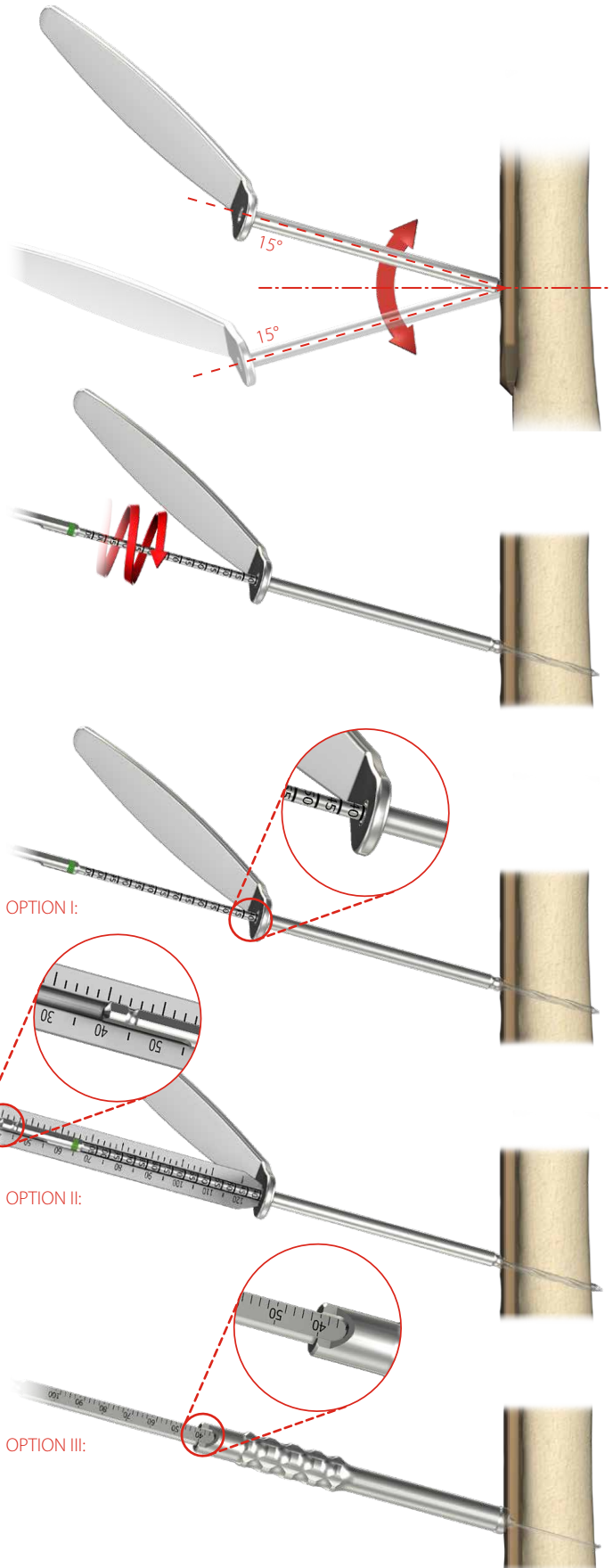

Screw insertion

Use torque limiting ratchet handle 2Nm **[40.6652.000]** and screwdriver tip T15 **[40.5677.000]** to insert the VA screw.



40.6652.000



40.5677.000

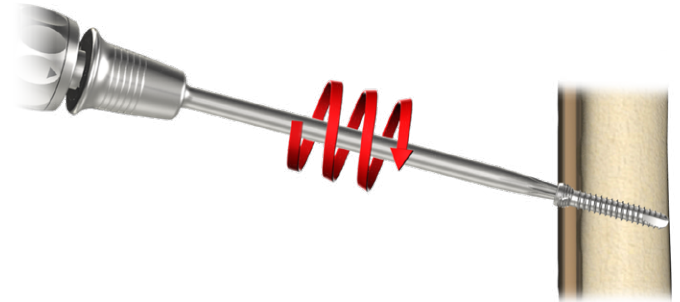

When using torque limiting handle to tighten the VA screw with large inclination in relation to the axis of the locking hole, the head of the screw may protrude above the plate. In this case, it may be necessary to use a handle ratchet device **[40.6654]** and screwdriver tip T15 **[40.5677]**. Use the instruments carefully to tighten the VA screw. Avoid damaging the screw socket or screwdriver tip. Do not insert the screw too deep into the plate.



40.6654.000



40.5677.000

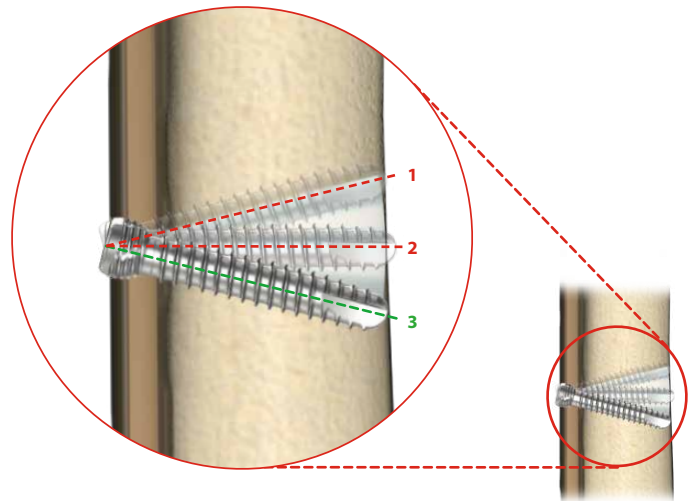

Change of the VA screw positioning



It is possible to lock the VA screw three times in the threaded hole of the plate. The hole in the plate in which the VA screw was locked cannot be used to insert a standard locking screw.

5. POSTOPERATIVE PROCEDURE

Introduce appropriate postoperative treatment. The physician decides on the post-operative treatment and its conduct. In order to avoid patient's movement limitations, introduce exercises as soon after surgery as possible. However, make sure that the limb is not fully loaded before fragments osteosynthesis is complete.

6. IMPLANT REMOVAL













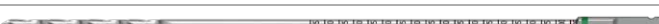

The physician decides about implant removal. In order to remove the implants from the body, unlock all the locking screws first and then remove them from the bone. This will prevent any rotation of the plate when removing the last locking screw.

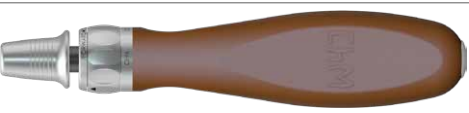







7. CATALOGUE PAGES

7a. INSTRUMENT SET

Instrument set for 5.0ChLP 4x4 1/2H

15.0205.206

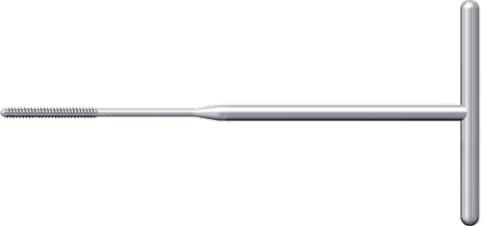
	Name	Catalogue No.	Pcs
	Tray for 5.0ChLP instrument set 4x4 1/2H	14.0205.206	1
	Kirschner wire 1.5/210	40.4592.210	4
	Drill 1.8/210	40.2063.212	2
	Drill with scale 2.5/210	40.5912.212	2
	Drill with scale 2.8/210	40.5653.212	2
	Screwdriver tip T15	40.5677.000	1
	Torque limiting ratchet handle 2Nm	40.6652.000	1
	Handle ratchet device	40.6654.000	1
	Protective guide 7/5	40.5672.000	2
	Guide VA 2.8	40.8206.028	1
	Compression guide 2.5	40.4804.725	1
	Guide sleeve 5.0/1.8	40.5673.718	2
	Guide sleeve 5.0/2.8	40.5673.728	4
	Depth measure	40.4639.550	1

	Name	Catalogue No.	Pcs
	Tray for 5.0ChLP instrument set 4x4 1/2H	14.0205.202	1
	Setting-compressing screw 2.8/180	40.5674.728	1
	Screw length measure	40.5675.500	1
	Plates bender 5.0	40.4643.500	2
	Tripod screwdriver tip 5.0ChLP	40.6271.500	1
	T15 screwdriver tip with holder	40.6254.000	1
	Cortical tap HA 3.5 with handle	40.2548.200	1
	Tap 5.0ChLP-3.5	40.5661.000	1
Optional instrument			
	Torque connector 2Nm	40.5927.020	1



5.0ChLP distal humerus Y plate

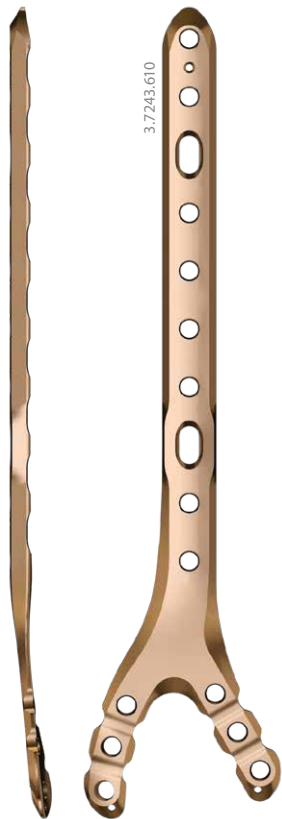

	Len		
5	116	3.7243.605	3.7244.605
6	129	3.7243.606	3.7244.606
8	155	3.7243.608	3.7244.608
10	181	3.7243.610	3.7244.610
12	207	3.7243.612	3.7244.612

5-16	116 259



	3.5200.012+095	✓		✓	✓	✓		3.5
	4.5236.012+095		✓	✓	✓	✓		3.5
	3.1306.012+095	✓		✓		✓		4.5

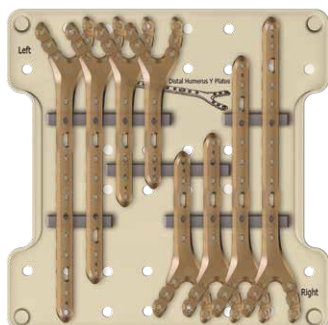

Tray for plates 5.0ChLP
3.7243/3.7244 4x4 1/2H Поддон для блокируемых пластин 5,0ChLP 3.7243/3.7244 4x4 1/2H

14.0205.429

Plate 3.7243.608 trial
Plate 3.7244.608 trial

43.7243.608
43.7244.608

7c. SCREWS

5.0ChLP self-tapping screw 3.5



Len	Ti
12	3.5200.012
14	3.5200.014
16	3.5200.016
18	3.5200.018
20	3.5200.020
22	3.5200.022
24	3.5200.024
26	3.5200.026
28	3.5200.028
30	3.5200.030
32	3.5200.032
34	3.5200.034
36	3.5200.036
38	3.5200.038
40	3.5200.040
42	3.5200.042
44	3.5200.044
46	3.5200.046
48	3.5200.048
50	3.5200.050
52	3.5200.052
54	3.5200.054
56	3.5200.056
58	3.5200.058
60	3.5200.060
65	3.5200.065
70	3.5200.070
75	3.5200.075
80	3.5200.080
85	3.5200.085

5.0ChLP screw VA 3.5



Len	Co
12	4.5236.012
14	4.5236.014
16	4.5236.016
18	4.5236.018
20	4.5236.020
22	4.5236.022
24	4.5236.024
26	4.5236.026
28	4.5236.028
30	4.5236.030
32	4.5236.032
34	4.5236.034
36	4.5236.036
38	4.5236.038
40	4.5236.040
42	4.5236.042
44	4.5236.044
46	4.5236.046
48	4.5236.048
50	4.5236.050
52	4.5236.052
54	4.5236.054
56	4.5236.056
58	4.5236.058
60	4.5236.060
65	4.5236.065
70	4.5236.070
75	4.5236.075
80	4.5236.080
85	4.5236.085
90	4.5236.090
95	4.5236.095

Cortical self-tapping screw 3.5



Len	Ti
10	3.1306.010
12	3.1306.012
14	3.1306.014
16	3.1306.016
18	3.1306.018
20	3.1306.020
22	3.1306.022
24	3.1306.024
26	3.1306.026
28	3.1306.028
30	3.1306.030
32	3.1306.032
34	3.1306.034
36	3.1306.036
38	3.1306.038
40	3.1306.040
45	3.1306.045
50	3.1306.050
55	3.1306.055
60	3.1306.060
65	3.1306.065
70	3.1306.070
75	3.1306.075
80	3.1306.080
85	3.1306.085

4.5ChLP screw 2.4



Len	Ti
16	3.5225.016
18	3.5225.018
20	3.5225.020
22	3.5225.022
24	3.5225.024
26	3.5225.026
28	3.5225.028
30	3.5225.030
32	3.5225.032
34	3.5225.034
36	3.5225.036
38	3.5225.038
40	3.5225.040

ChM sp. z o.o.

Lewickie 3b
16-061 Juchnowiec Kościelny
Polska

tel. +48 85 86 86 100

fax +48 85 86 86 101

chm@chm.eu

www.chm.eu



CE 0197