







CHM[®]

Thoracolumbar spine stabilization system CHARSPINE2 MIS

- *IMPLANTS*
- *INSTRUMENT SET - BASIC 15.0913.101*
- *INSTRUMENT SET - ADDITIONAL 15.0913.202*
- *SURGICAL TECHNIQUE*



SYMBOLS DESCRIPTION

	Caution - pay attention to a special procedure.
	Perform the activity under X-Ray control.
	Information about the next stages of a procedure.
	Proceed to the next stage.
	Return to the specified stage and repeat the activity.
	Before using the product, carefully read the Instructions for Use. It contains, among others, indications, contraindications, side effects, recommendations and warnings related to the use of the product.
	The above description is not a detailed instruction of conduct. The surgeon decides about choosing the operating procedure.

www.chm.eu

Document No ST/86A
Date of issue 28.05.2019
Review date P-004-05.04.2023

The manufacturer reserves the right to introduce design changes.

Updated INSTRUCTIONS FOR USE are available at the following website: ifu.chm.eu

1. INTRODUCTION	4
2. IMPLANTS	5
3. INSTRUMENT SET	10
3.1. CONTAINERS ARRANGEMENT	15
4. SURGICAL TECHNIQUE	16
4.1. Patient positioning	16
4.2. Marking the incision site	16
4.3. Trocar insertion	17
4.4. Guide rod insertion	19
4.5. Use of depth measure [40.8586.000]	19
4.6. Protective guides assembly	20
4.7. Screw insertion	20
4.8. Cement augmentation of screws (<i>optional</i>)	27
4.9. Length measurement, use with the applicator, shaping and installation of the rod	29
4.10. Rod locking, distraction, compression, final tightening	31
5. REVISION SURGERY	38

1. INTRODUCTION

CHARSPINE2 MIS Thoracolumbar spine stabilization system is a set of implants designed for the treatment of the thoracic-lumbar spine using a minimally invasive technique. The system is used with the posterior approach (*from Th1 to S1*) in skeletally mature patients.

INDICATIONS

Implants of the CHARSPINE2 MIS system enable treatment with restoration of the physiological curves of the affected motion segment of the spine through proper vertebral reposition.

Indications:

- degenerative disc disease (*DDD*),
- spondylolistheses,
- fractures and dislocations,
- deformities (*e.g.: scolioses, kyphoses*),
- tumours,
- stenoses,
- pseudoarthroses,
- failed previous fusion.

CONTRAINDICATIONS

Contraindications may be relative or absolute. The choice of a particular device must be carefully considered in terms of patient's overall condition. Some conditions such as, e.g.:

- spine infection,
- morbid obesity,
- mental illness,
- alcohol or drug addiction,
- pregnancy,
- suspected or documented allergy or intolerance to implant materials, foreign bodies,
- inadequate tissue coverage or open wounds in the operative site, may preclude or reduce the chance of the successful outcome.



A detailed list of contraindications is provided in the Instructions for Use (*IFU*) for the product.

WARNINGS

The safety and effectiveness of spinal systems based on the transpedicular screws stabilization have been established only for diseases of the spine caused by significant mechanical instability or deformities requiring surgical immobilization. The safety and effectiveness of these systems for other conditions remain unknown. A successful result is not always achieved in every surgical case. This fact is especially true in the cases where other patient's conditions may compromise the results. The proper patient selection, compliance of the patient and observance of post-operative recommendations will greatly affect the results. It has been proven that the bone union is less likely to occur among smoking patients. These patients should be informed about this fact and warned of this consequence.



A detailed list of warnings, precautions and postoperative recommendations is provided in the Instructions for Use (*IFU*) for the product.



Implants of the CHARSPINE2 MIS system manufactured by ChM sp. z o.o. were designed and tested only for use with the ChM instrument set intended to be used with them. This surgical technique is intended as a guide only. As with any other surgical procedure, the surgeon should be thoroughly trained before surgery and must consider the individual needs of each patient.

2. IMPLANTS

Main features and benefits

The presented implants and instruments are designed for posterior approach using a minimally invasive technique. The offered range of implants is made of titanium and its alloys and cobalt alloy in accordance with ISO 5832 standard.

CHARSPINE2 MIS Polyaxial screw

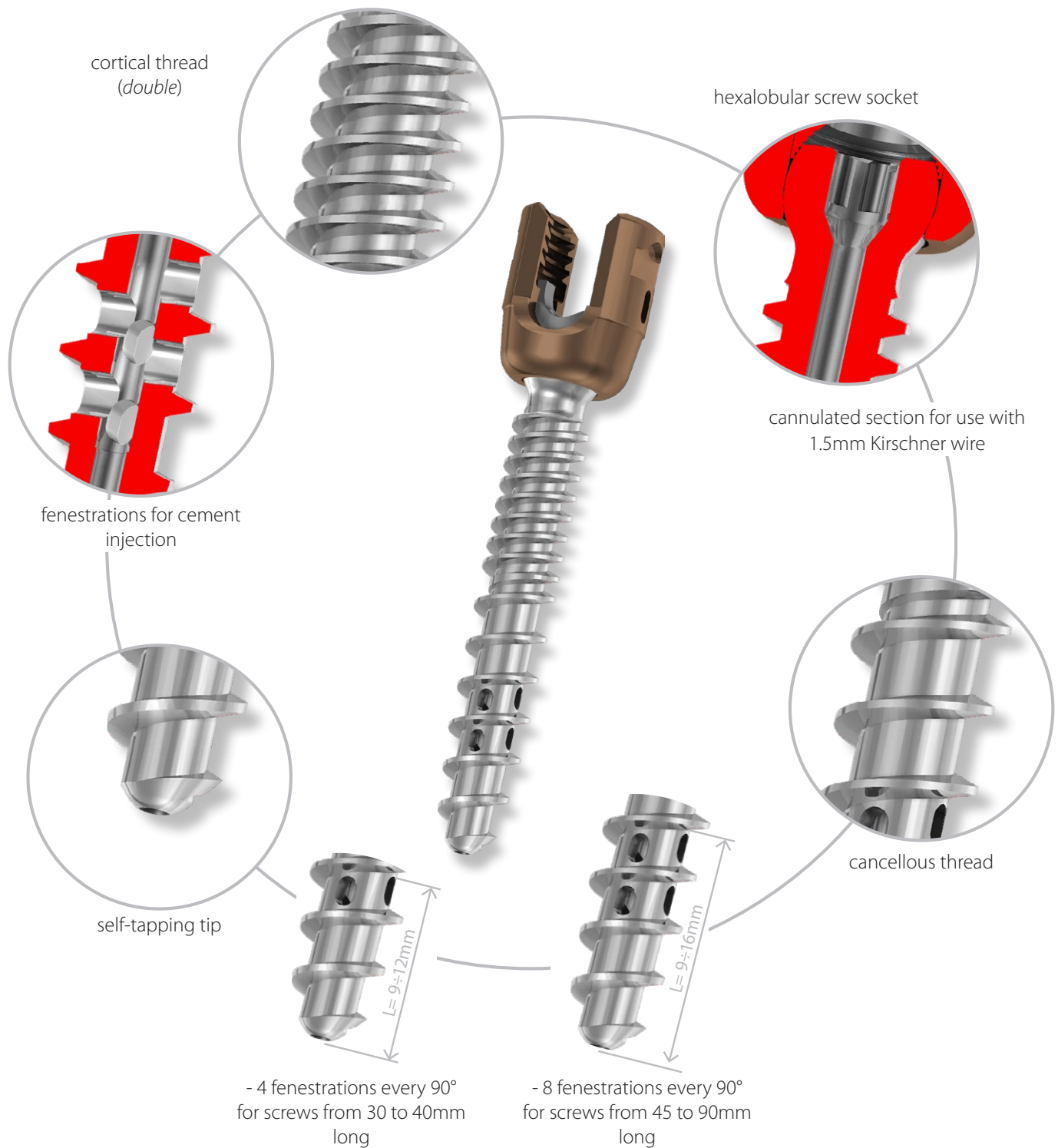

CHARSPINE2 MIS POLYAXIAL SCREW

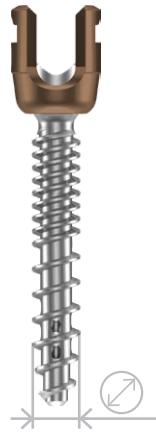

CHARSPINE2 LOCKING SCREW



Ti



3.6160.000



Len	Ti	Len	Ti
30	3.6565.030	30	3.6572.030
35	3.6565.035	35	3.6572.035
40	3.6565.040	40	3.6572.040
45	3.6565.045	45	3.6572.045
30	3.6566.030	50	3.6572.050
35	3.6566.035	55	3.6572.055
40	3.6566.040	60	3.6572.060
45	3.6566.045	65	3.6572.065
30	3.6567.030	70	3.6572.070
35	3.6567.035	75	3.6572.075
40	3.6567.040	80	3.6572.080
45	3.6567.045	85	3.6572.085
50	3.6567.050	90	3.6572.090
55	3.6567.055	95	3.6572.095
60	3.6567.060	100	3.6572.100
65	3.6567.065	30	3.6573.030
30	3.6568.030	35	3.6573.035
35	3.6568.035	40	3.6573.040
40	3.6568.040	45	3.6573.045
45	3.6568.045	50	3.6573.050
50	3.6568.050	55	3.6573.055
55	3.6568.055	60	3.6573.060
60	3.6568.060	65	3.6573.065
65	3.6568.065	70	3.6573.070
30	3.6569.030	75	3.6573.075
35	3.6569.035	80	3.6573.080
40	3.6569.040	85	3.6573.085
45	3.6569.045	90	3.6573.090
50	3.6569.050	95	3.6573.095
55	3.6569.055	100	3.6573.100
60	3.6569.060	30	3.6574.030
65	3.6569.065	35	3.6574.035
30	3.6570.030	40	3.6574.040
35	3.6570.035	45	3.6574.045
40	3.6570.040	50	3.6574.050
45	3.6570.045	55	3.6574.055
50	3.6570.050	60	3.6574.060
55	3.6570.055	65	3.6574.065
60	3.6570.060	70	3.6574.070
65	3.6570.065	75	3.6574.075
30	3.6571.030	80	3.6574.080
35	3.6571.035	85	3.6574.085
40	3.6571.040	90	3.6574.090
45	3.6571.045	95	3.6574.095
50	3.6571.050	100	3.6574.100
55	3.6571.055		
60	3.6571.060		
65	3.6571.065		
70	3.6571.070		
75	3.6571.075		
80	3.6571.080		
85	3.6571.085		
90	3.6571.090		

Ø4.5 Ø5.0 Ø5.5 Ø6.0 Ø6.5 Ø7.0 Ø7.5 Ø8.5 Ø9.5 Ø10.5



CHARSPINE2 MIS Rod 6

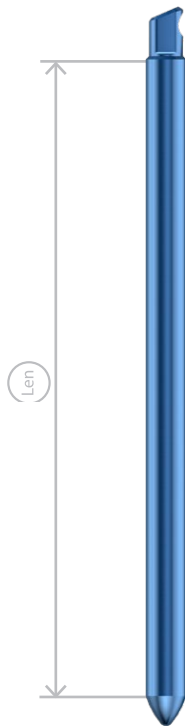

Len	Ti
30	3.6900.030
35	3.6900.035
40	3.6900.040
45	3.6900.045
50	3.6900.050
55	3.6900.055
60	3.6900.060
65	3.6900.065
70	3.6900.070
75	3.6900.075
80	3.6900.080
85	3.6900.085
90	3.6900.090
95	3.6900.095
100	3.6900.100
110	3.6900.110
120	3.6900.120
130	3.6900.130
140	3.6900.140
150	3.6900.150
160	3.6900.160
170	3.6900.170
180	3.6900.180
190	3.6900.190
200	3.6900.200
300	3.6900.300
400	3.6900.400
500	3.6900.500
600	3.6900.600

CHARSPINE2 MIS Hard rod 6

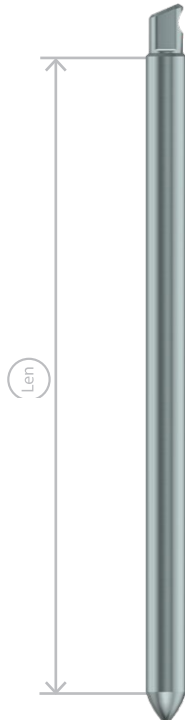

Len	Co
30	4.6900.030
35	4.6900.035
40	4.6900.040
45	4.6900.045
50	4.6900.050
55	4.6900.055
60	4.6900.060
65	4.6900.065
70	4.6900.070
75	4.6900.075
80	4.6900.080
85	4.6900.085
90	4.6900.090
95	4.6900.095
100	4.6900.100
110	4.6900.110
120	4.6900.120
130	4.6900.130
140	4.6900.140
150	4.6900.150
160	4.6900.160
170	4.6900.170
180	4.6900.180
190	4.6900.190
200	4.6900.200
300	4.6900.300
400	4.6900.400
500	4.6900.500
600	4.6900.600

CHARSPINE2 MIS Curved rod 6

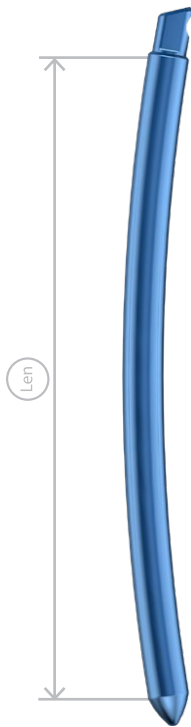

Len	Ti
30	3.6901.030
35	3.6901.035
40	3.6901.040
45	3.6901.045
50	3.6901.050
55	3.6901.055
60	3.6901.060
65	3.6901.065
70	3.6901.070
75	3.6901.075
80	3.6901.080
85	3.6901.085
90	3.6901.090
95	3.6901.095
100	3.6901.100
110	3.6901.110
120	3.6901.120
130	3.6901.130
140	3.6901.140
150	3.6901.150
160	3.6901.160
170	3.6901.170
180	3.6901.180
190	3.6901.190
200	3.6901.200

CHARSPINE2 MIS Curved hard rod 6



Len	Co
30	4.6901.030
35	4.6901.035
40	4.6901.040
45	4.6901.045
50	4.6901.050
55	4.6901.055
60	4.6901.060
65	4.6901.065
70	4.6901.070
75	4.6901.075
80	4.6901.080
85	4.6901.085
90	4.6901.090
95	4.6901.095
100	4.6901.100
110	4.6901.110
120	4.6901.120
130	4.6901.130
140	4.6901.140
150	4.6901.150
160	4.6901.160
170	4.6901.170
180	4.6901.180
190	4.6901.190
200	4.6901.200

40.8593.000
 PALETTE FOR CHARSPINE2 MIS IMPLANTS - RODS

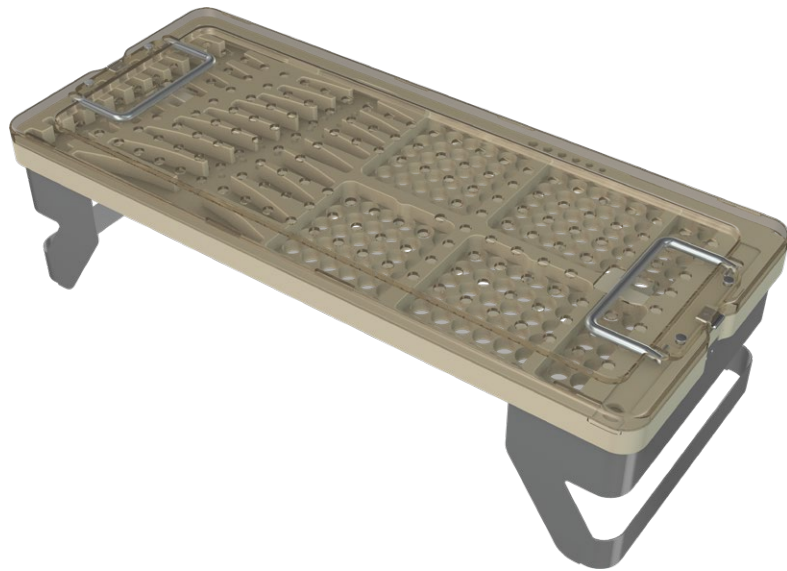

Polyaxial screws

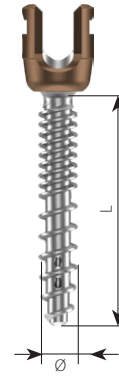

Locking screw



Rods

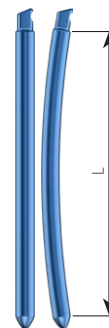









Screw diameter	Length L	Quantity
5.0	30	2
	35	2
	40	2
	45	2
5.5	35	6
	40	6
	45	6
	50	6
	55	6
	60	6
6.0	35	6
	40	6
	45	6
	50	6
	55	6
	60	6
6.5	35	6
	40	6
	45	6
	50	6
	55	6
	60	6
7.0	35	6
	40	6
	45	6
	50	6
	55	6
	60	6
7.5	35	2
	40	2
	45	2
	50	2
	55	2
	60	2
-	-	-
-	30	1
	35	1
	40	1
	45	1
	50	1
	55	1
	60	1
	65	1
	70	1
	75	1
	80	1
	85	1
	90	1
	95	1
	100	1
	110	1
120	1	
130	1	
140	1	
150	1	
160	1	

3. INSTRUMENT SET







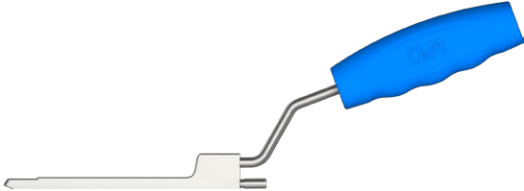



The CHARSPINE2 MIS polyaxial screws instrument set consists of the following modules:



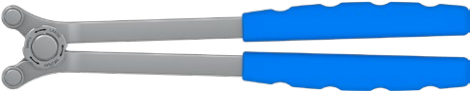

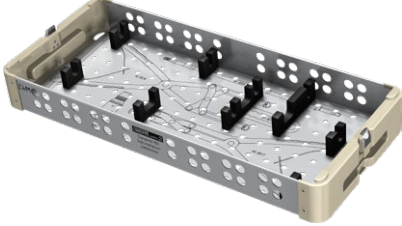

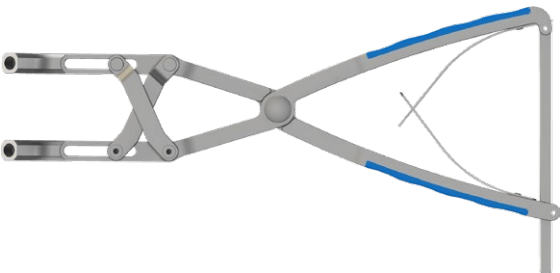



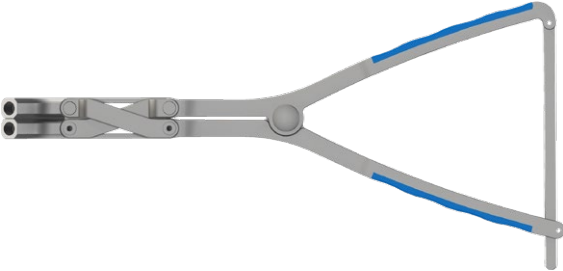

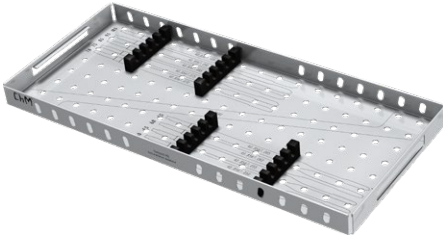



- CHARSPINE2 MIS Instrument set - basic [15.0913.101]
- CHARSPINE2 MIS Instrument set - additional 1 [15.0913.202]

CHARSPINE2 MIS Instrument set - basic [15.0913.101]			
CHARSPINE2 MIS Instrument set	Name	Catalogue no.	Pcs
	Container 9x4H	14.0913.101	1
	Protective guide I Protective guide is used to expose the operating field.	40.8562.000	1
	Protective guide II Protective guide is used to expose the operating field.	40.8563.000	1
	Protective guide III Protective guide is used to expose the operating field.	40.8564.000	1
	Protective guide IV Protective guide is used to expose the operating field.	40.8588.000	1
	Trocar Trocar is used to penetrate the cortical layer of the arch and insert the guide rod.	40.8561.000	1
	Screwdriver T30 Screwdriver T30 is used for the insertion and initial locking of the locking screws. With the rod impactor, a set is used to press the rod to the bottom of the pedicle screw socket.	40.8574.000	1
	Screwdriver T30 Screwdriver T30 is intended for use for removal of the locking screw in revision procedures.	40.8111.000	1
	Applicator Applicator is used to insert the spinal rod.	40.8571.000	1
	Applicator Applicator is used to insert the spinal rod.	40.8572.000	1

CHARSPINE2 MIS Instrument set - basic [15.0913.101]







CHARSPINE2 MIS Instrument set	Name	Catalogue no.	Pcs
	Container 9x4H	14.0913.102	1
	Oval head ratchet handle Oval head ratchet handle is used with wrenches for screws and cortical taps (interchangeably with T-type ratchet handle 40.8085.000).	40.8086.000	2
	Manual cannulated reamer The reamer is used to prepare the holes in the pedicles of vertebral arches.	40.8565.000	1
	Gauge Gauge is used to measure the length of the rod	40.8570.000	1
	Bone rasp Bone rasp is used to prepare the pedicle for the transpedicular screw head.	40.8566.000	1
	Adjustable rod bender Adjustable rod bender is used to bend the rod to desired shape	40.8074.000	1
	Wrench for polyaxial screws Wrench for polyaxial screws is used for mounting and insertion of CHARSPINE2 MIS polyaxial transpedicular screws. It is intended for use with oval head ratchet handle.	40.8568.000	2
	Rod trial 6/300 Rod trials are used for initial rough assessment of the size and shape of the spinal rod in the spinal stabilization procedures using transpedicular screws.	40.5246.300	2
	Container 9x4H	14.0913.103	1
	Screwdriver tip T30 Screwdriver tip T30 is used with a T-type torque handle 12Nm [40.8087.000] for nal locking of transpedicular screws, hooks and lateral connectors.	40.8084.000	1
	Reposition plate Reposition plate is used in compression and distraction procedures. Guide sleeves are inserted into the holes in the plate.	40.8578.000	1
	Parallel compression forceps The forceps are used with protective guide II and are intended for procedure of vertebrae compression.	40.8576.000	1

CHARSPINE2 MIS Instrument set - basic [15.0913.101]

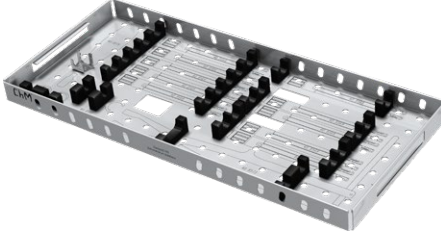
CHARSPINE2 MIS Instrument set	Name	Catalogue no.	Pcs
	Parallel distraction forceps The forceps are used with protective guide II and are intended for procedure of vertebrae distraction.	40.8577.000	1
	T-type torque handle 12Nm T-type torque handle 12Nm is intended to be used with screwdriver tip T30 [40.8084.000] and is used for nal tightening of the locking screws into the transpedicular screws, hooks and lateral connectors.	40.8087.000	1
	Tray 9x4 1/2H	14.0913.201	1
	Cortical tap 4.5	40.8567.045	1
	Cortical tap 5.0	40.8567.050	1
	Cortical tap 5.5	40.8567.055	1
	Cortical tap 6.0	40.8567.060	1
	Cortical tap 6.5	40.8567.065	1
	Cortical tap 7.0	40.8567.070	1
	Cortical tap 7.5	40.8567.075	1
	Cortical tap 8.5	40.8567.085	1
	Cortical tap 9.5	40.8567.095	1
	Cortical tap 10.5	40.8567.105	1
	Stand Stand is used to store the guide rods 1.5/500. спиц-направителей 1,5/500.	40.8590.000	1
	Guide rod 1.5/500 Blunt rod. It is the guiding element for other instruments, e.g. used for screws insertion.	40.8559.000	10
	Container lid 9x4	14.0913.104	1

Cortical taps are intended for usage with ratchet handles [40.8085.000] or [40.8086.000] and may be used for tapping the vertebral arch pedicles prior to screw insertion.

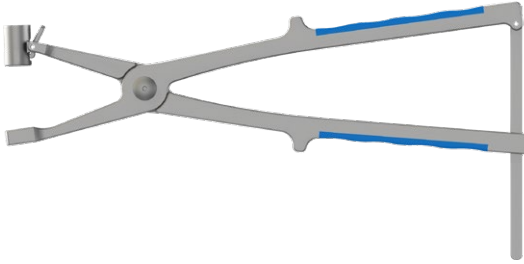









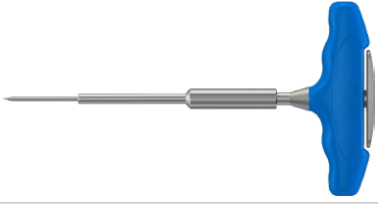

CHARSPINE2 MIS Instrument set - additional 1 15.0913.202]

CHARSPINE2 MIS Instrument set - additional 1	Name	Catalogue no.	Pcs
	Tray 9x4 1/2H	14.0913.202	1
	Counter wrench Counter wrench is used to ensure rotational stability of the implants during nal tightening of the locking screws.	40.8579.000	1
	Guide II Guides II are used with distraction and compression forceps.	40.8575.000	2
	Wrench Wrench facilitates the removal of the guide sleeve and tightening of the cannula for bone cement.	40.8580.000	1
	Rod impactor Rod impactor with screwdriver T30 is used to push the rod to the bottom of the screw.	40.8573.000	1
	Guide sleeve Guide sleeve when attached to the screw, facilitates the introduction of the spinal rod, allows the insertion of the locking screw, cooperates with instruments used in distraction, compression and rod positioning procedures.	40.8569.000	10



Instruments mentioned below are not included in the standard instrument set.

In order to include them to the ordered CHARSPINE2 MIS instruments, please contact your local representative or ChM Sales Department.

	Name	Catalogue no.	Pcs
	Cannula for bone cement Single use cannula for bone cement is intended to be used with the head of the CHARSPINE2 MIS screw. The universal Luer thread allows the cannula to be connected with the mixing and delivery system for bone cement.	40.8591.000	1
	Alignment trial for cannula Alignment trial for cannula, inserted through the cannula for bone cement attached to the CHARSPINE2 MIS screw, is intended to confirm the coaxiality of the holes in the cannula and screw.	40.8592.000	1
	Pusher Pusher is used to remove residual bone cement from the cannula.	40.8596.000	1
	Trocar Trocar is used as an alternative to the standard trocar [40.8561.000] in situations where the surgical conditions or the surgeon's preferences require the use of a shorter instrument.	40.8601.000	1
	Connector Connector is used with distraction forceps; can be used when decompression of a broken vertebra is required.	40.8595.000	1
	Guide rod 1.5/500 Rod with a sharp tip; used as a guiding element for other instruments, e.g. for screws insertion.	40.8560.000	1
	Guide rod 1.5/500 Rod with a sharp threaded (<i>self-drilling</i>) tip; used as a guiding element for other instruments, e.g. for screws insertion.	40.8558.000	1
	Guide rod 1.5/500 Rod with a blunt threaded tip; used as a guiding element for other instruments, e.g. for screws insertion.	40.8557.000	1
	Guide rod 1.5/600 Non-standard, longer (600mm) rod with a blunt tip.	40.8559.600	1
	Guide rod 1.5/600 Non-standard, longer (600mm) rod with a sharp tip.	40.8560.600	1
	Guide rod 1.5/600 Non-standard, longer (600mm) rod with a sharp threaded (<i>self-drilling</i>) tip.	40.8558.600	1
	Guide rod 1.5/600 Non-standard, longer (600mm) rod with a blunt threaded tip.	40.8557.600	1
	Container Container for storage and sterilization of 600mm guide rods.	40.8555.000	1
	Depth measure Depth measure determines the length of the pedicle screw on the basis of the guide wire inserted in the pedicle.	40.8586.000	1

3.1. CONTAINERS ARRANGEMENT

Containers for basic instrument set [15.0913.101] and additional instruments [15.0913.202]

No.	Name	Catalogue No.	Pcs
1	Container lid 9x4	14.0913.104	2
2	Tray 9x4 1/2H	14.0913.201	1
3	Container 9x4H	14.0913.101	1
4	Tray 9x4 1/2H	14.0913.202	1
5	Container 9x4H	14.0913.103	1
6	Container 9x4H	14.0913.102	1



4. SURGICAL TECHNIQUE

4.1. PATIENT POSITIONING

The patient is placed prone on rubber-foam supports. In order to avoid pressure and bed-sores, a bolster is used to support the mouth, nose and eyes. Make sure the patient's stomach is free of pressure. This is especially important when decompressing the spine, since a compressed abdomen can cause venous congestion and, as a result, increased intraoperative bleeding.

4.2. MARKING THE INCISION SITE

Using the A/P imaging, determine the lines running centrally through the vertebral pedicles at the levels to be treated.

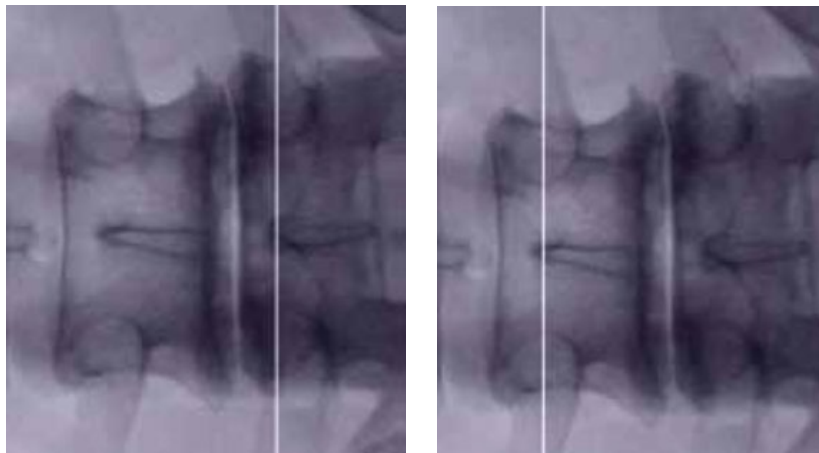

The AP imaging should be done carefully. The pedicles should be symmetrical and the spinous process should be located centrally between the pedicles. The upper endplate should be parallel to the X-Ray direction emitted by the C-arm.

The insertion point for the transpedicular screws is located at the intersection of a line running centrally through the pedicles and a line parallel to the center line and about 4cm off that line. At the intersection, incision about 1.5cm long should be made. Should the surgical approach be hindered, the incisions may be widened.

Central line

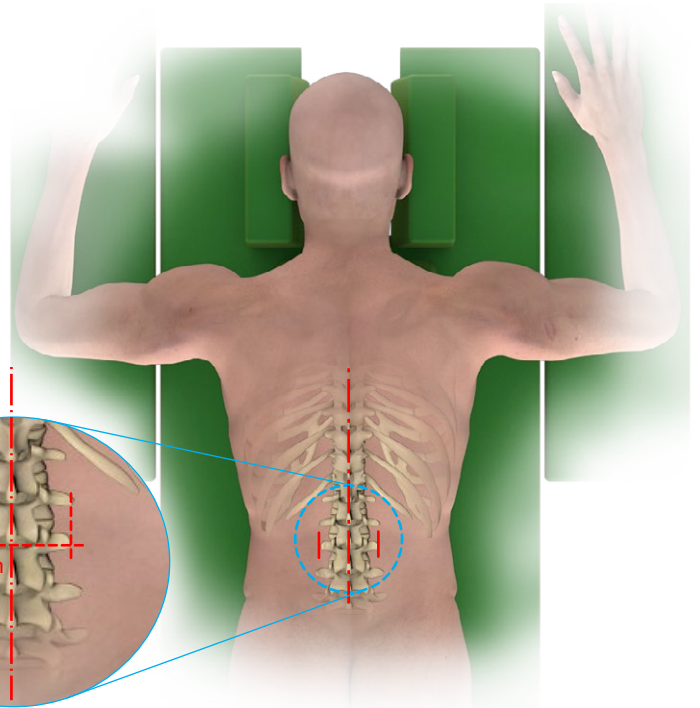
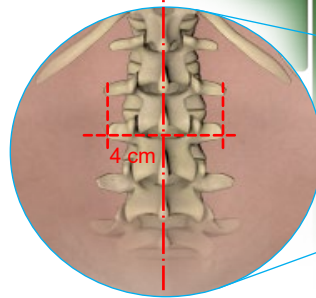

4.3. TROCAR INSERTION

Trocar [40.8561.000] should be gently inserted through the incision towards the insertion point at the pedicle arch. This point is located at the intersection of the line dividing the transverse processes in half and the line running along the lateral edge of the upper articular process.

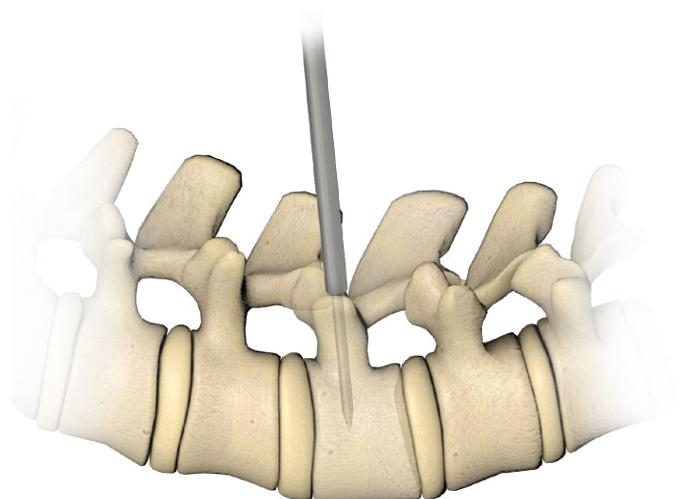
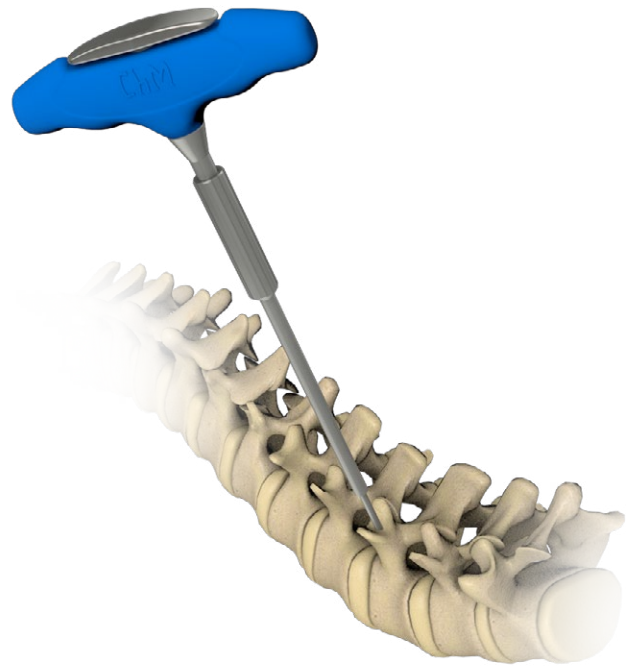
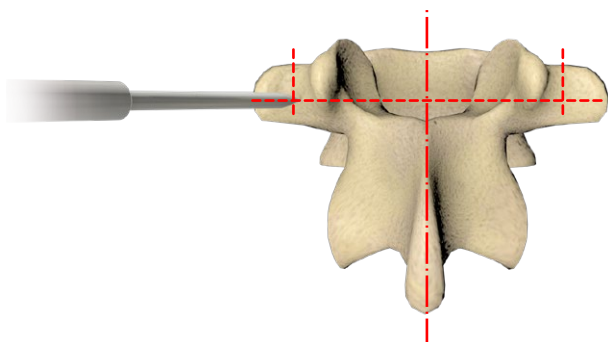

When the trocar tip rests against the bone, confirm its positioning by taking lateral and A/P images. Then insert the trocar through the pedicle into the vertebral body to the desired depth. Confirm correct insertion of the trocar.

The trocar is equipped with a depth limiter that determines the maximum depth the trocar tip can be inserted. The limiter can also be used to determine the screw length. Use X-Ray control and trocar to mimic the insertion depth of the screw. Rotate the limiter clockwise until it rests against the bone surface. The depth read from the measure corresponds to the length the screw is intended to be implanted.



Having reached the desired depth, rotate counterclockwise the handle of the needle to remove it from the trocar.

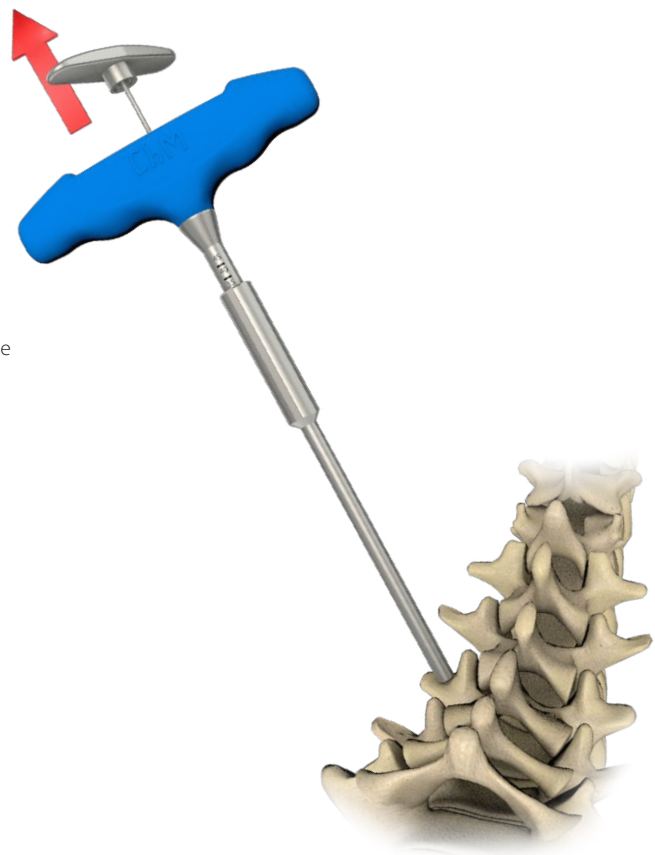

4.4. GUIDE ROD INSERTION

Insert the guide rod [40.8559.000] where the pin was. Afterwards, remove the trocar. When removing the trocar, make sure the guide rod does not fall out.



40.8559.000

4.5. USE OF DEPTH MEASURE [40.8586.000]



CAUTION: When determining the length of the pedicle screw using the depth measure [40.8586.000], make sure the guide rod is positioned at the depth of screw insertion. If necessary, use X-Ray imaging to re-position the rod.

Install the depth measure [40.8586.000] onto the guide rod until it rests on the bone. The value indicated on the depth measure by the marker of the rod corresponds to the length of the pedicle screw.

40.8586.000

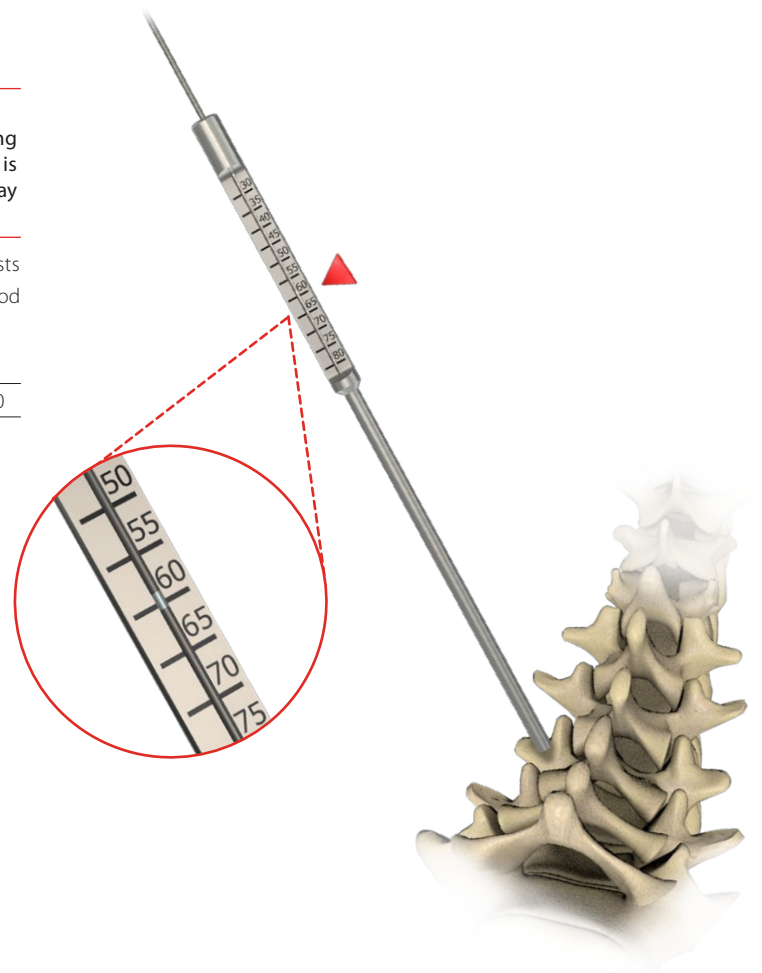

4.6. PROTECTIVE GUIDES ASSEMBLY

Protective guides [40.8562.000], [40.8563.000], [40.8564.000], [40.8588.000] provide tissue protection and facilitate instruments insertion.

Use the guide rod to insert the sleeves until they rest against the bone. Start with the sleeve with the smallest diameter and continue until the largest diameter sleeve is installed, tissues are spread and the surgical approach is prepared.

Remove all sleeves but the largest one.

I		40.8562.000
II		40.8563.000
III		40.8564.000
IV		40.8588.000

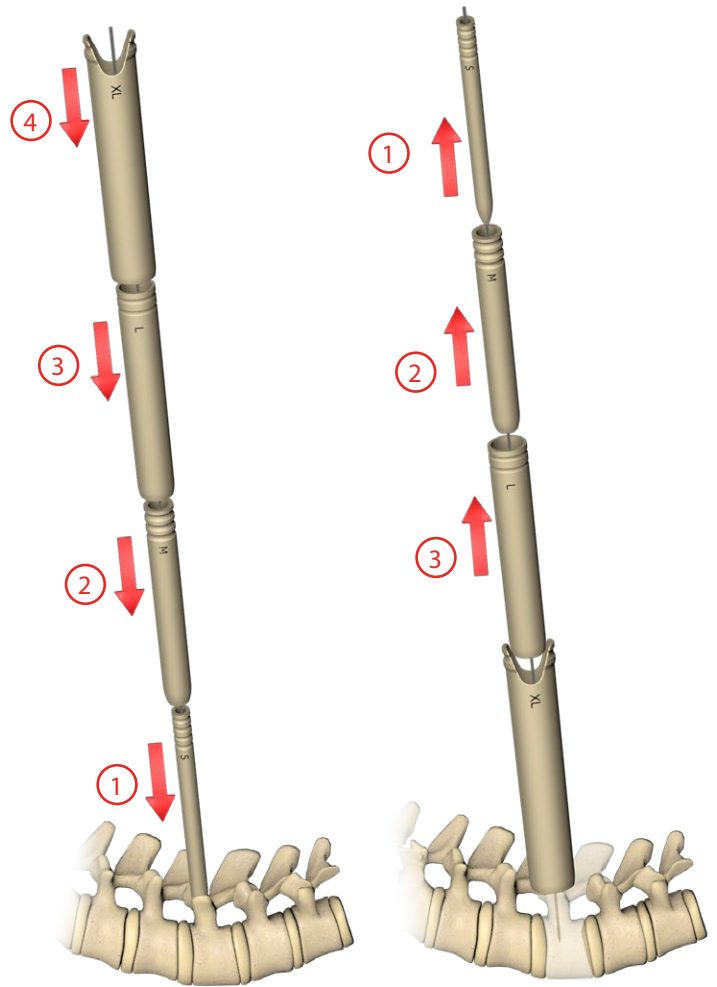

4.7. SCREW INSERTION

4.7.1. PREPARATION OF THE PEDICLE OF VERTEBRAL ARCH

Attach manual cannulated reamer [40.8565.000] to the oval head ratchet handle [40.8086.000].

Introduce the combined instrument applying pressure to the handle and making gentle rotational and swinging movements until the reamer rests on the bone (the reamer stops sinking into the pedicle).



The smallest protective sleeve compatible with the reamer [40.8565.000] is sleeve II [40.8563.000].

	40.8565.000
	40.8086.000

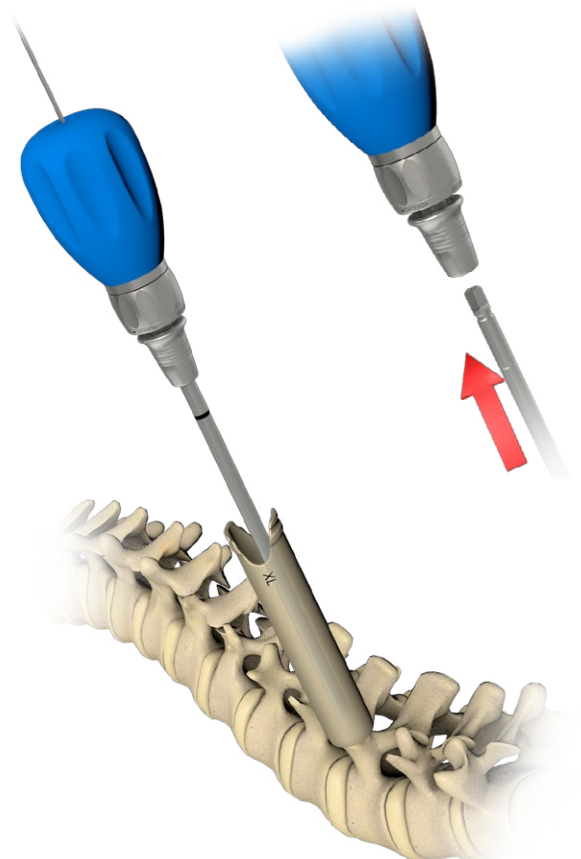

4.7.2. REAMING OF TRANSVERSE AND ARTICULAR PROCESSES (OPTIONAL)

Remove the oval head ratchet handle [40.8086.000] from the manual cannulated reamer leaving it embedded in the pedicle.

Introduce bone rasp [40.8566.000] on the reamer and applying pressure to the rasp, make gentle rotational and swinging movements. When the marker on the reamer aligns with the horizontal hole in the bone rasp, the bottom edge of the rasp is level with the bearing surface of the reamer.



The smallest protective sleeve compatible with the rasp [40.8566.000] is sleeve III [40.8564.000].

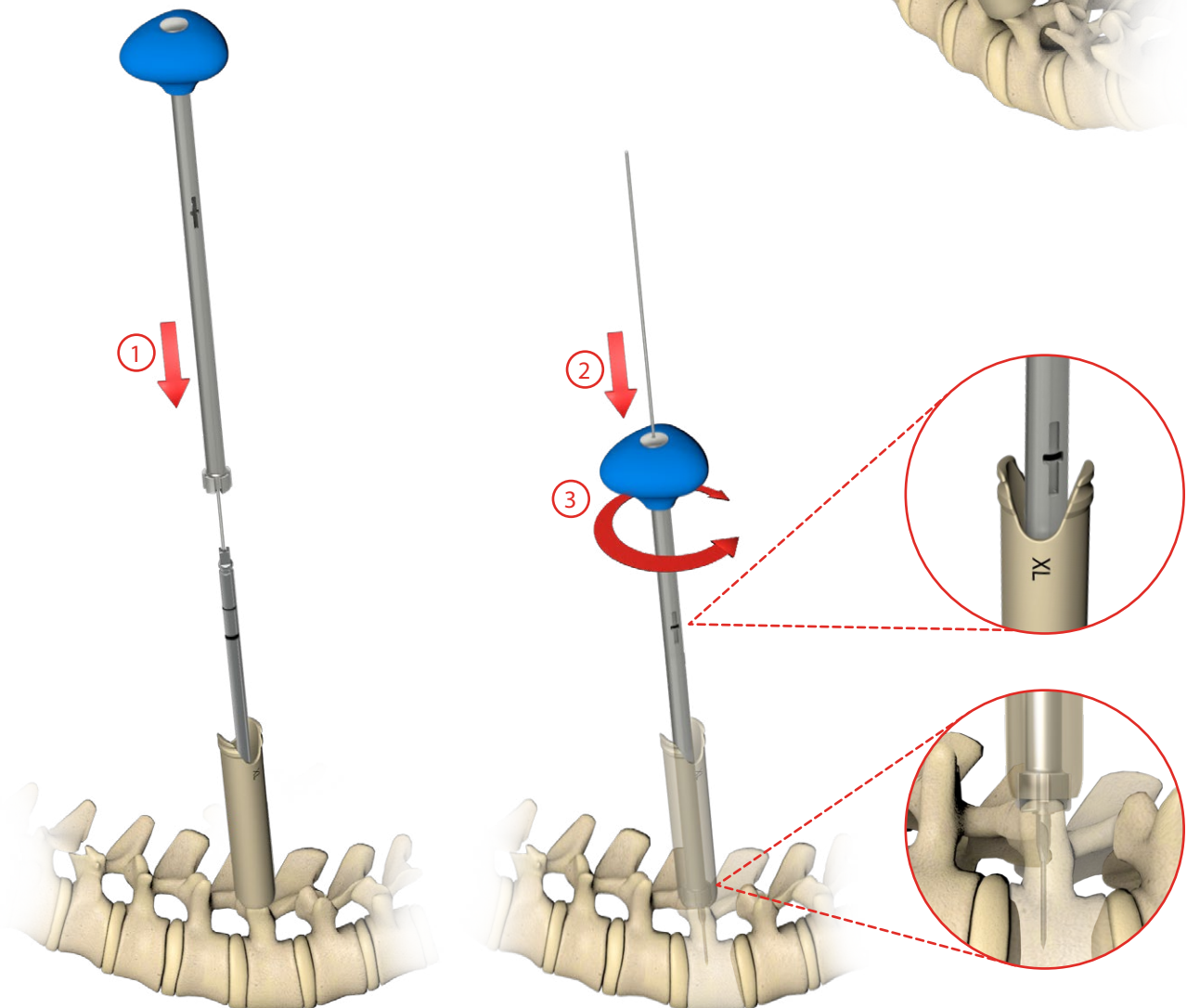
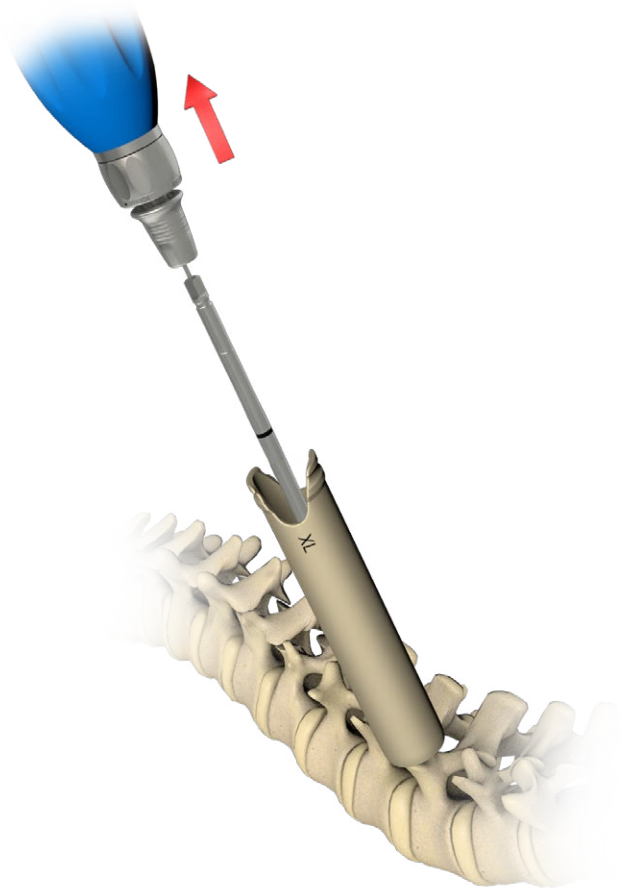

Carefully remove the rasp and reamer, protecting the guide rod from being pulled out of the pedicle.

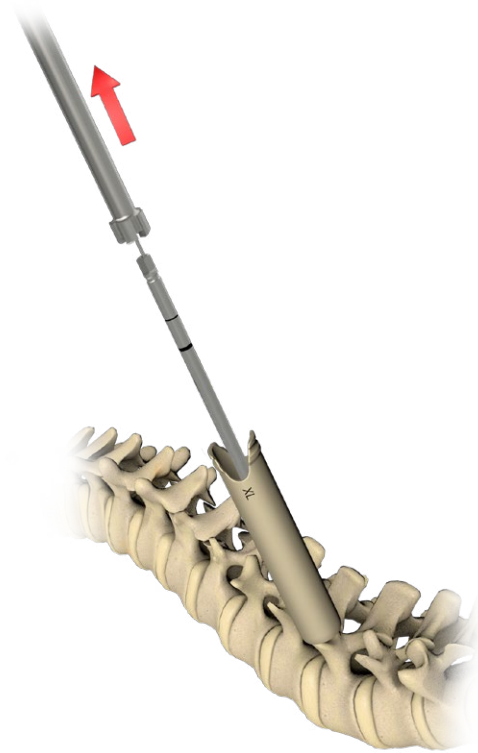

4.7.3. HOLES THREADING (OPTIONAL)

CHARSPINE2 MIS screws are self-tapping, therefore, in most cases, there is no need to thread the pedicles of vertebral arches. However, for clinical cases requiring threading, cortical taps [40.8567.045-40.8567.105] mounted in the oval head ratchet handle [40.8086.000] can be used. There is a scale marked on the taps that allows for rough determination of the depth at which the tap has been inserted (*before threading, define the number of scale that levels with the upper edge of the protective guide, then after finishing the threading, a second reading is made accordingly; the difference between the readings is equal to the approximate depth of the tap insertion*).

CAUTION:

During threading, be careful and do not change the position of the protective guide as this may result in an incorrect reading of the threading depth.



The smallest protective sleeve compatible with a tap is sleeve II [40.8563.000].

	40.8567.045
	40.8567.050
	40.8567.055
	40.8567.060
	40.8567.065
	40.8567.070
	40.8567.075
	40.8567.085
	40.8567.095
	40.8567.105
	40.8086.000

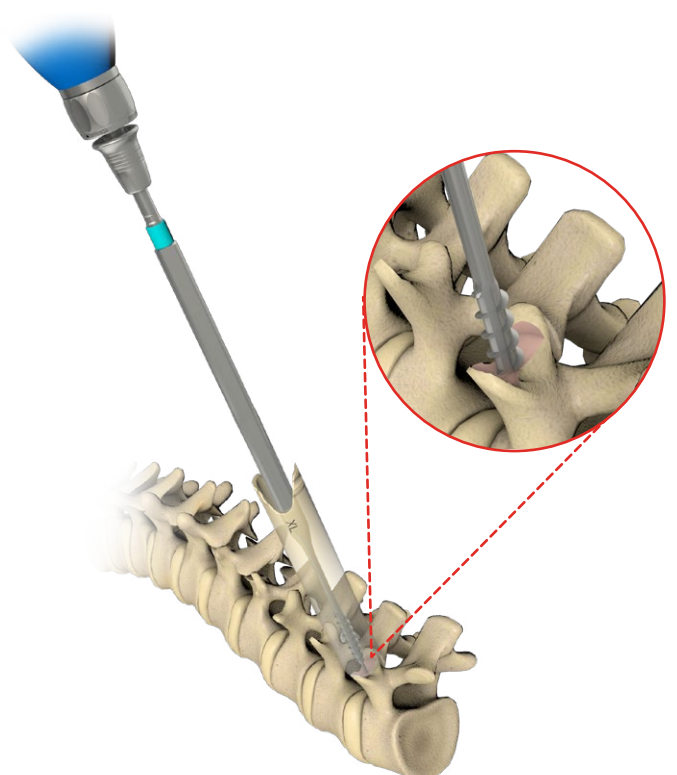

4.7.4. TRANSPEDICULAR SCREW-TO-GUIDE SLEEVE CONNECTION

Rotate the sleeve handle [40.8569.000] UNLOCK until resistance is felt.
Do not use excessive force.

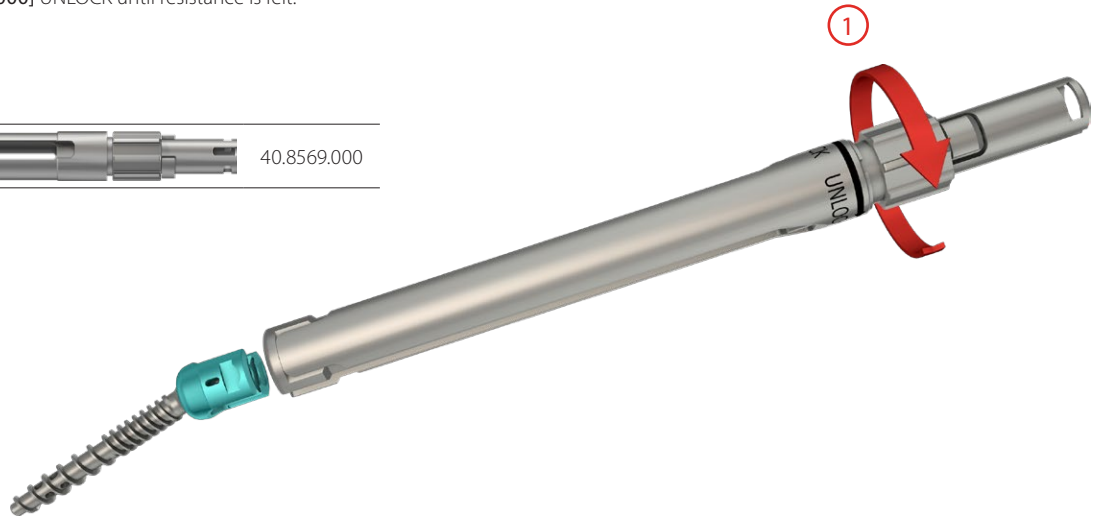

Lock the head of the screw in the guide sleeve.

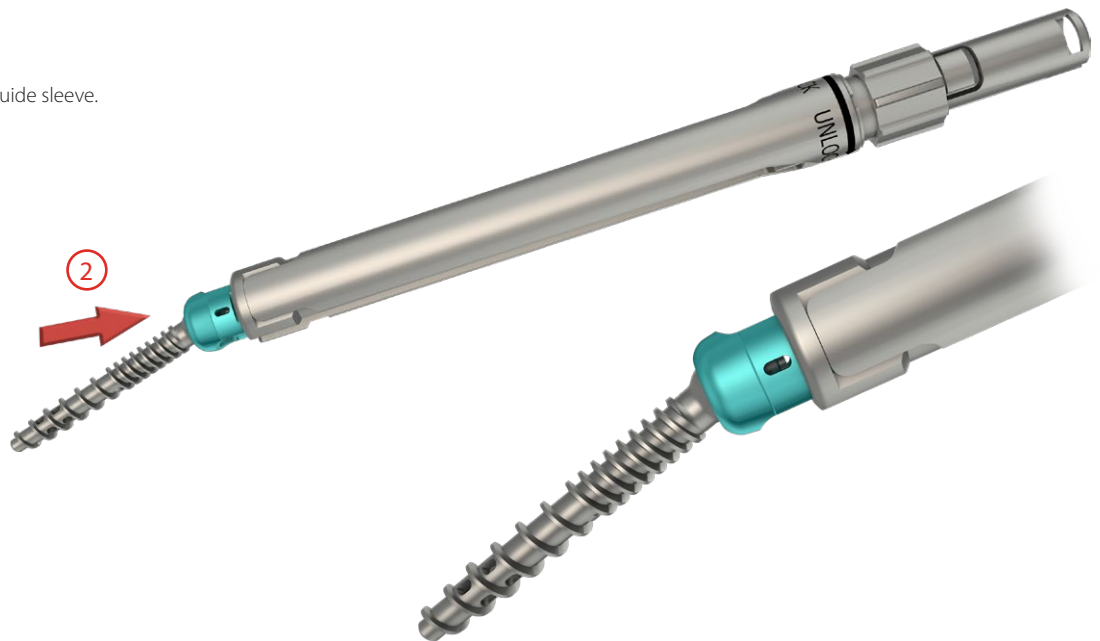

Rotate the sleeve handle LOCK until resistance is felt and tighten up slightly.
Do not use excessive force for tightening.
The screw will be locked in the sleeve.

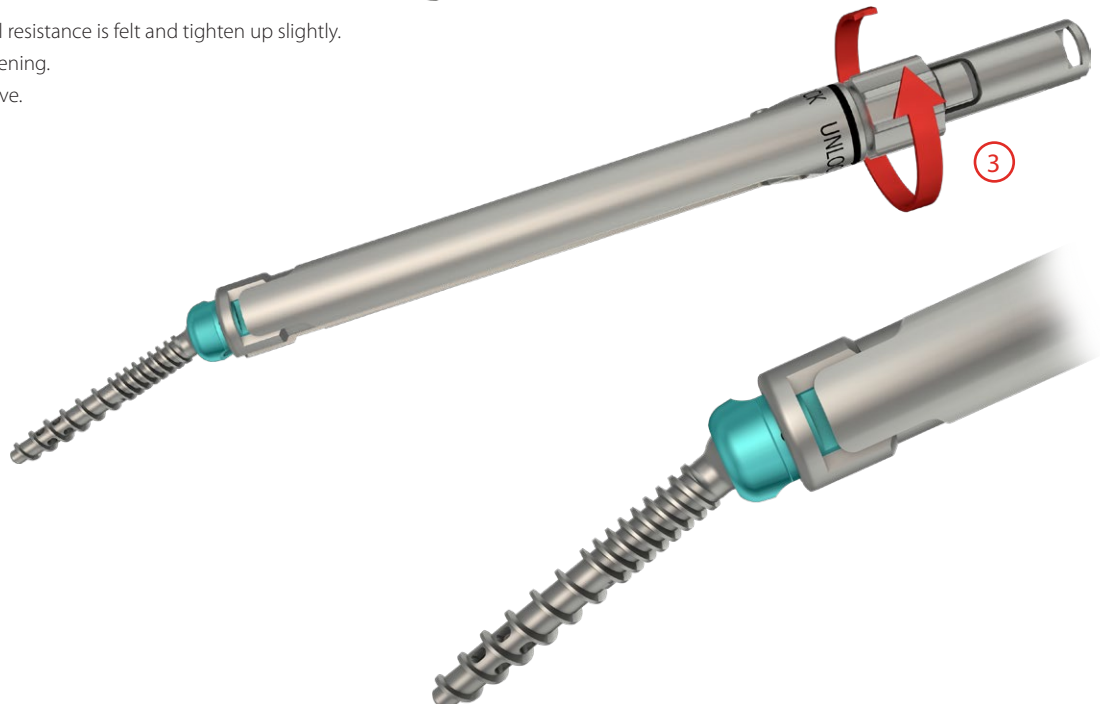

4.7.5. SCREWS INSERTION

The instrument set includes two wrenches for polyaxial screws [40.8568.000]. These wrenches are designed for use with oval head ratchet handle [40.8086.000] and are equipped with a ratchet mechanism that prevents loosening of the tip-screw connection during insertion. To disconnect the shaft from the wrench [40.8568.000], turn the wrench knob to DISMOUNT position, press and hold the place on the wrench marked as PUSH, and then remove the shaft out of the wrench sleeve.

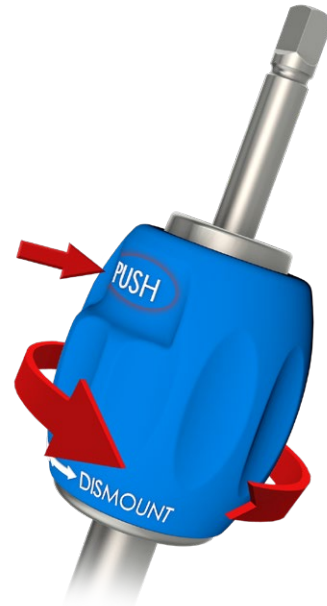
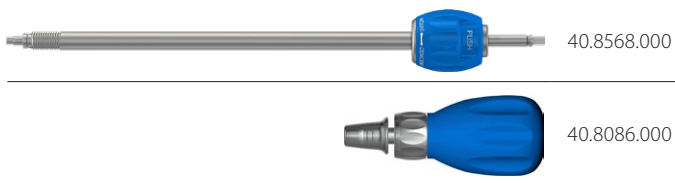

Attach the wrench to oval head ratchet handle [40.8086.000].

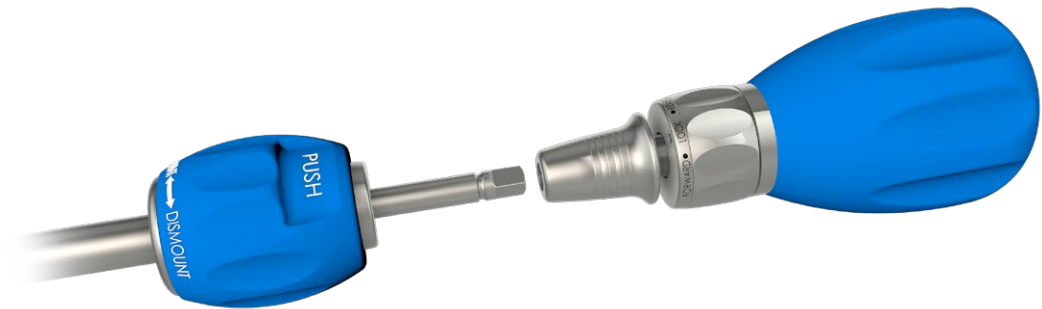

Then insert the wrench tip into the chosen transpedicular screw.

Rotate the wrench knob clockwise to tighten the threaded outer sleeve of the wrench [40.8568.000] until the tip is fully seated in the bottom of the screw socket. The tightening direction is marked with an arrow and the word MOUNT. When tightening, with increasing resistance, the wrench knob will automatically move to the position that activates the mechanism preventing the screw from loosening.

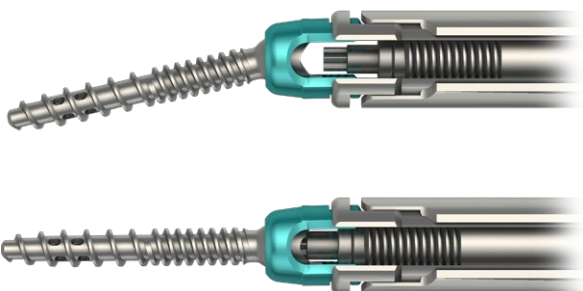
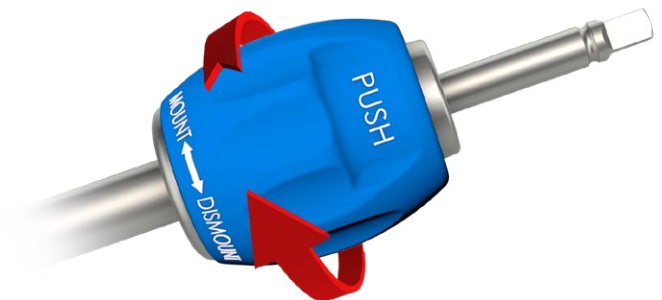

There are 10 guide sleeves in the instrument set allowing for simultaneous stabilization of 5 levels of the spine.



The screw insertion should be controlled in two planes using a fluoroscope.



It should be remembered that the correct screws positioning is achieved by screwing in the screws and not by screwing them out.

Backing the screw out may result in the loss of a stable anchoring and the need for use of a larger diameter screw.



The smallest protective sleeve compatible with the guide sleeve [40.8569.000] is sleeve IV [40.8588.000].

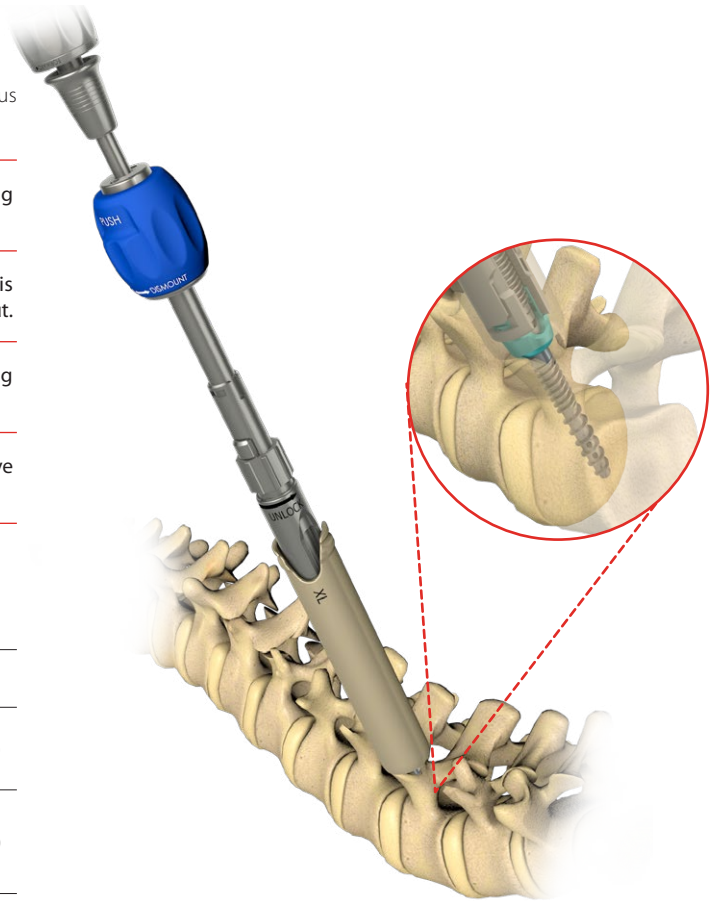
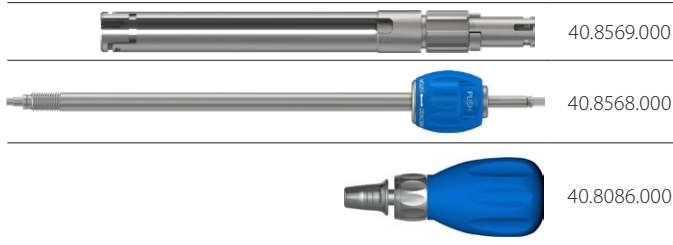

When implanting the screw, do not hold the oval knob of the wrench [40.8568.000], as this will disengage the safety mechanism.

If there is a need to use the other hand to hold the wrench, hold the part of the sleeve below the oval knob.

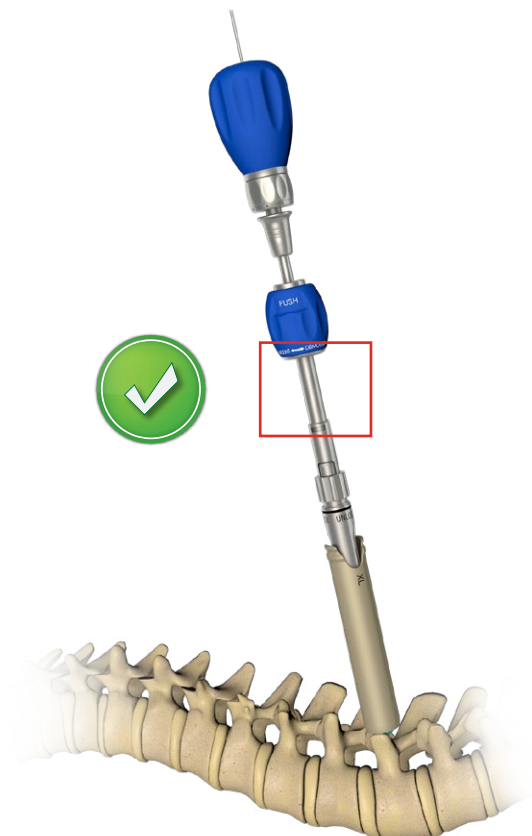

To remove the wrench [40.8568.000] from the screw, rotate the silicone knob several times counterclockwise (*DISMOUNT direction*) until the wrench is completely unscrewed from the head of the pedicle screw. Remove the wrench from the guide sleeve.

**CAUTION:**

Make sure the guide rod is NOT 'pulled' by the inserted screw which would result in an uncontrolled deeper insertion of the rod.

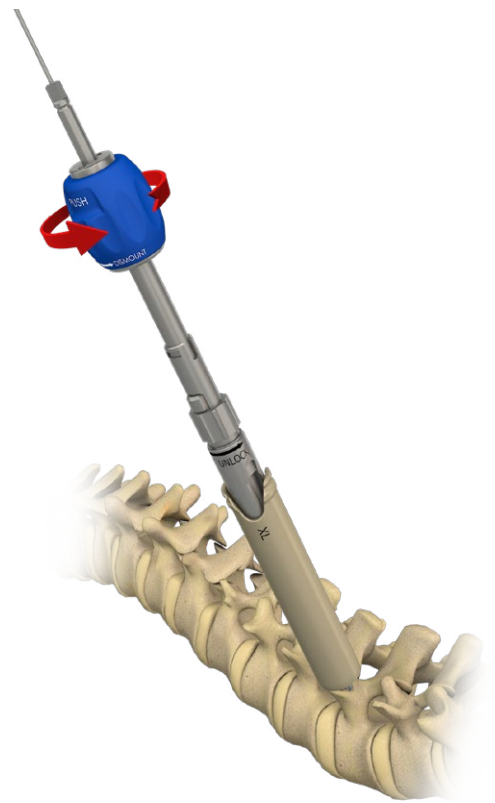

After screw insertion, if bone cementing is not intended, remove the guide rod and protective sleeve IV [40.8588.000].

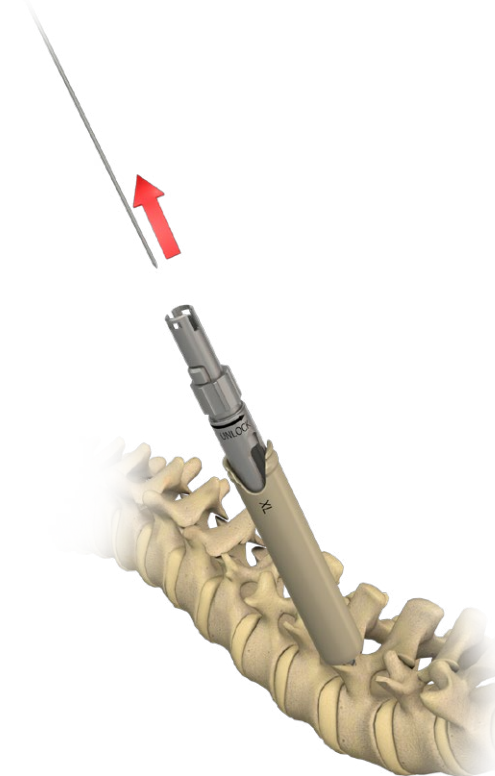

Repeat the steps of chapter 4.6 to enter the intended number of screws.

4.8. CEMENT AUGMENTATION OF SCREWS (OPTIONAL)

4.8.1. USE OF CANNULA FOR BONE CEMENT

If a bone cement is to be injected into the vertebral body, a cannula for bone cement [40.8591.000] (not included in the standard instrument set.), through which the cement will be injected, should be attached to the implanted screw (before removing the guide rod). To do this, hold the flattened tip of the cannula and insert its other end, using the guide rod and guide sleeve, into the screw head and then tightened it up (clockwise rotation). Remove the guide rod.

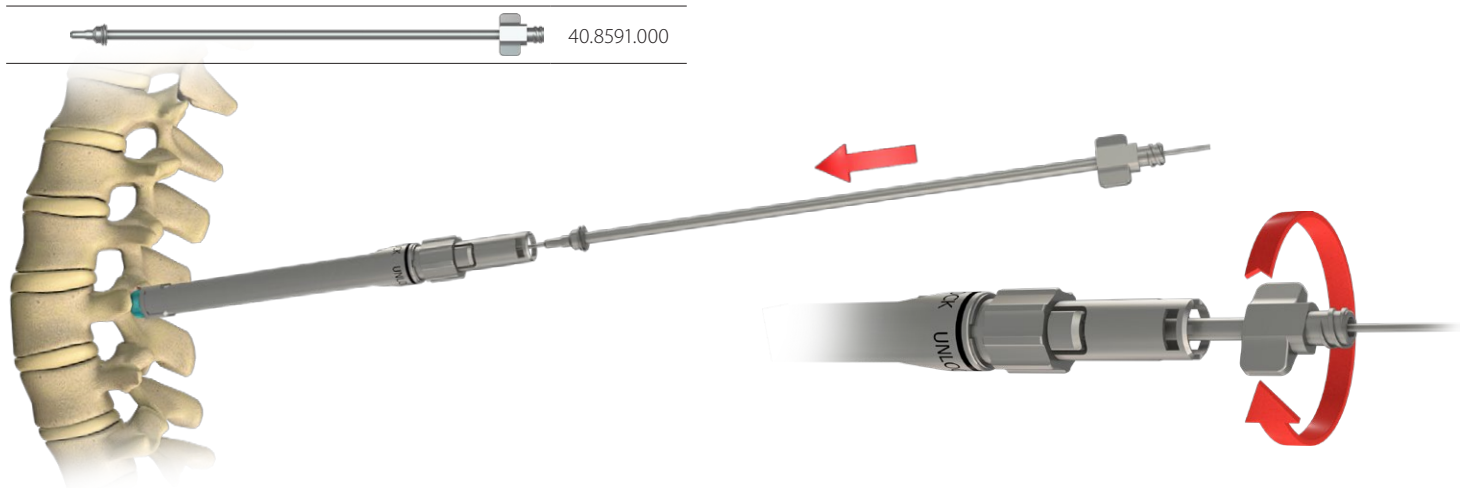

To confirm the coaxiality of the holes in the cannula and the screw, use the alignment trial for cannula [40.8592.000] (not included in the standard instrument set). The trial should be inserted into the cannula until stop.

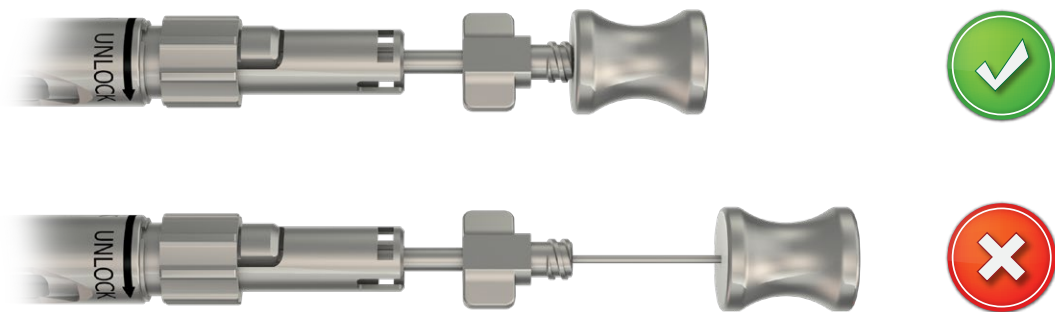
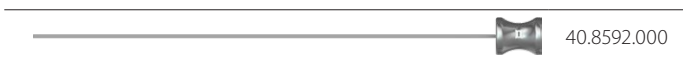

If the alignment trial cannot be fully inserted, the cannula for bone cement has not been properly connected to the screw. In such situation, loosen slightly the cannula in the screw (counterclockwise rotation), reposition the screw head using the guide sleeve and then push the trial to the end and tighten fully the cannula.



Should the screw been inserted so deep that the screw head was immobilized by the neighbouring bone, it may be necessary to slightly back out the screw to allow the head to be mobilized and the cannula to be properly inserted.



Incorrect connection of the cannula with the screw can cause cement leakage at the connection point.

Before cement injection, all cannulas for bone cement should be attached to the screws.

4.8.2. CEMENT PREPARATION AND INJECTION

For cement preparation, refer to the Instructions for Use for bone cement and cement mixing/delivery device system. The cannula for bone cement is equipped with a standardized Luer Lock thread, enabling a tight connection with the cement mixing/delivery device.

 The volume of cement in the cannula [40.8591.000] is 1.2 ml.

Mix the cement as instructed and suck it into the cement mixing/delivery device. Before injecting, wait until the cement reaches the right viscosity.

 Fluoroscopy should be used throughout the cement injection procedure to control the cement flow.

When using cement to augment multiple screws and levels, attention must be paid not to exceed the working time of the cement prior to completion of cement delivery through the screws. When the cement working time is close to completion, a new cement package should be used.



The cannula for bone cement as well as the mixing/delivery device are designed for use with one package of bone cement only. If a second package of cement is needed, use a new cannula and mixing/delivery device.

Do not attempt to force the injection of cement if excessive resistance is felt. Always determine the cause of the resistance and take appropriate action. If the cement is seen outside of the vertebral body or in the circulatory system during the procedure, immediately stop injecting the cement.

Use pusher [40.8596.000] to remove the residual cement from the cannula (1.2 ml). Insert the pusher down the cannula. The pusher handle needs to rest against the cannula.



CAUTION:
Wipe clean the pusher after each use, thoroughly.

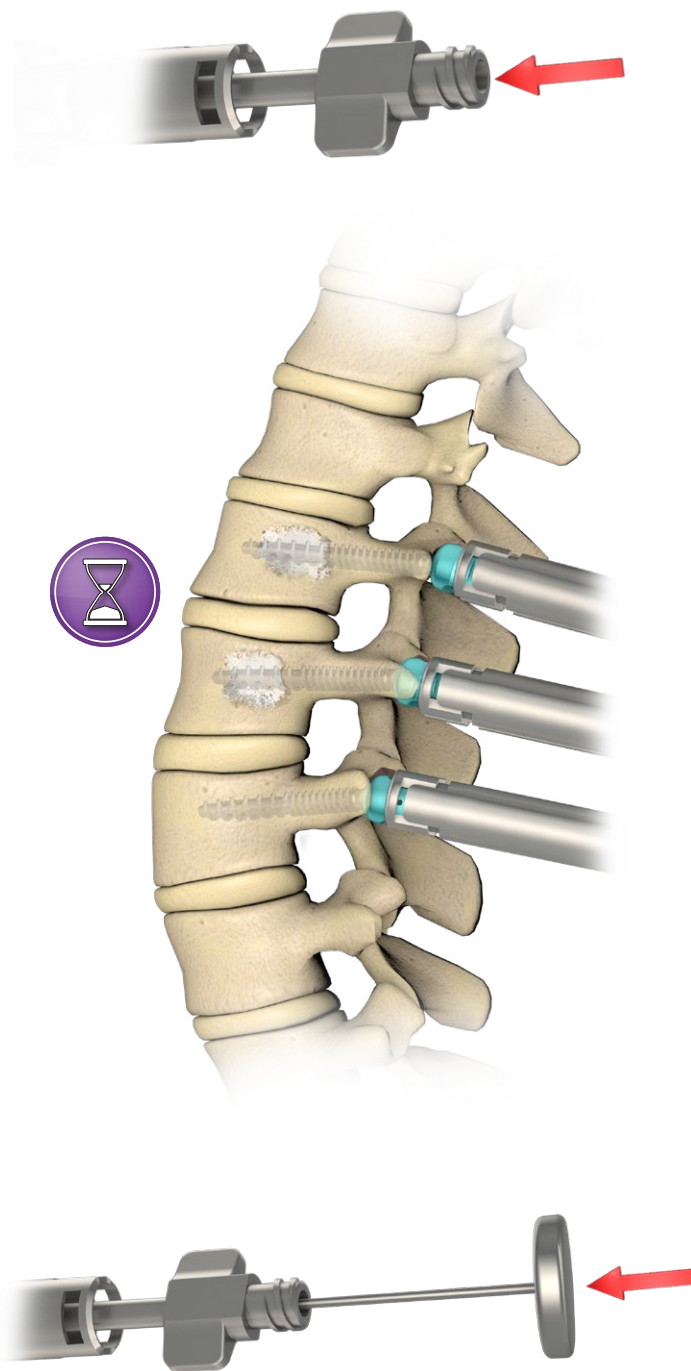

4.8.3. REMOVAL OF THE CANNULA FOR BONE CEMENT

After cementing, unscrew the cannula from the screw. Hold the guide sleeve [40.8569.000] with the other hand to counteract the removal process.

Use wrench [40.8580.000] to facilitate unscrewing, if required.

It is important, that after cementing and before removing the cannula from the screw, to make sure that the cement flow is stopped by backing out the cement feeder slightly.



It is critical that no torsion movement should be applied to the screw after injecting the cement in order to avoid breaking the cement bridges between screw and bone.

The cannula for bone cement and cement mixing/delivery device are disposable equipment and must be discarded after cementing.

4.9. LENGTH MEASUREMENT, USE WITH THE APPLICATOR, SHAPING AND INSTALLATION OF THE ROD

4.9.1. USE OF GAUGE [40.8570.000]

The measurement is made by placing the measuring levers of gauge [40.8570.000] in the guide sleeves [40.8569.000], and then reading the values from the measuring scale. The value on the scale indicates the length of the rod to be used for stabilization.



Only the accurate seating of the levers of the gauge at the bottom of the screw guarantees the correct measurement.



Before placing the gauge [40.8570.000] on the stand, set the scale along the measuring lever. To do this, unlock the measuring levers, fold the scale and relock the levers.



4.9.2. USE OF ROD TRIAL 6/300 [40.5246.300]

Applying the rod trial 6/300 [40.5246.300] to the skin surface next to the guide sleeves [40.8569.000] and read from the scale the value corresponding to the external dimension between the sleeves. The value on the scale indicates the length of the rod to be used for stabilization.



For accurate measurement, the guide sleeves [40.8569.000] should be parallel to each other.

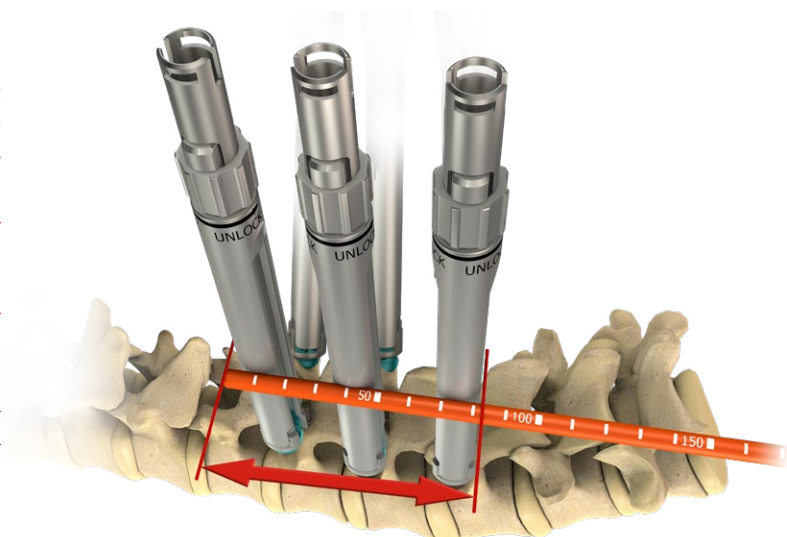

4.9.3. USE OF THE ROD WITH APPLICATOR AND ITS SHAPING

Two angular versions of the applicator are available: curved [40.8571.000] and straight [40.8572.000]. To attach the rod to the applicator, loosen the locking pin by turning the applicator wheel and place the spinal rod in the applicator socket with the drill hole facing up as shown in the picture. Immobilize the rod by tightening the locking pin.

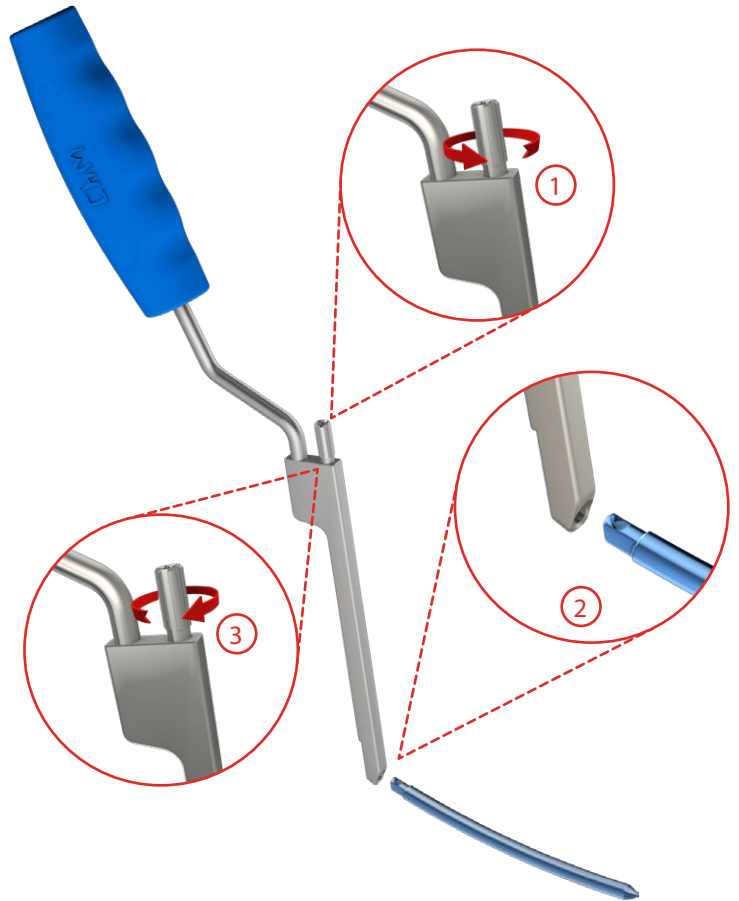
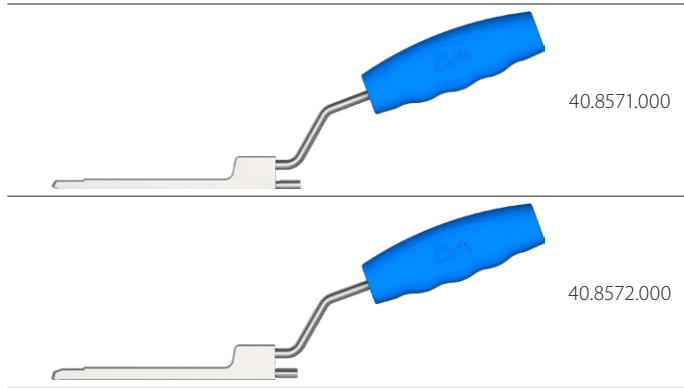

Two types of rods are available in the CHARSPINE2 MIS system: straight and pre-bent. If the rod needs to be bent to obtain the planned curvature of the spine (e.g. lordosis or kyphosis), the rod should be profiled accordingly, with the use of adjustable rod bender [40.8074.000].

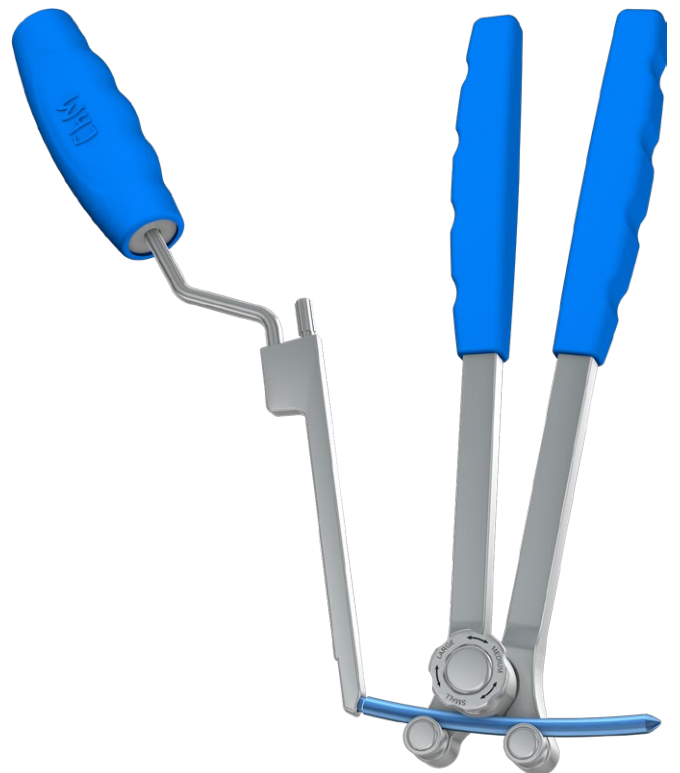
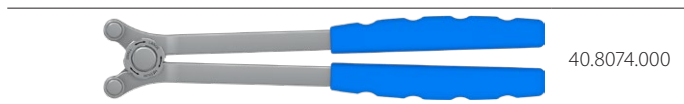

4.9.4. ROD INSERTION

The rod insertion should proceed from the extreme screws (*in the rostral or caudal direction*). Insert the rod percutaneously through the longitudinal channels located in the guide sleeves [40.8569.000]. Make sure the rod is inserted into all the screws.



Verify the correct positioning of the rod with a fluoroscope.

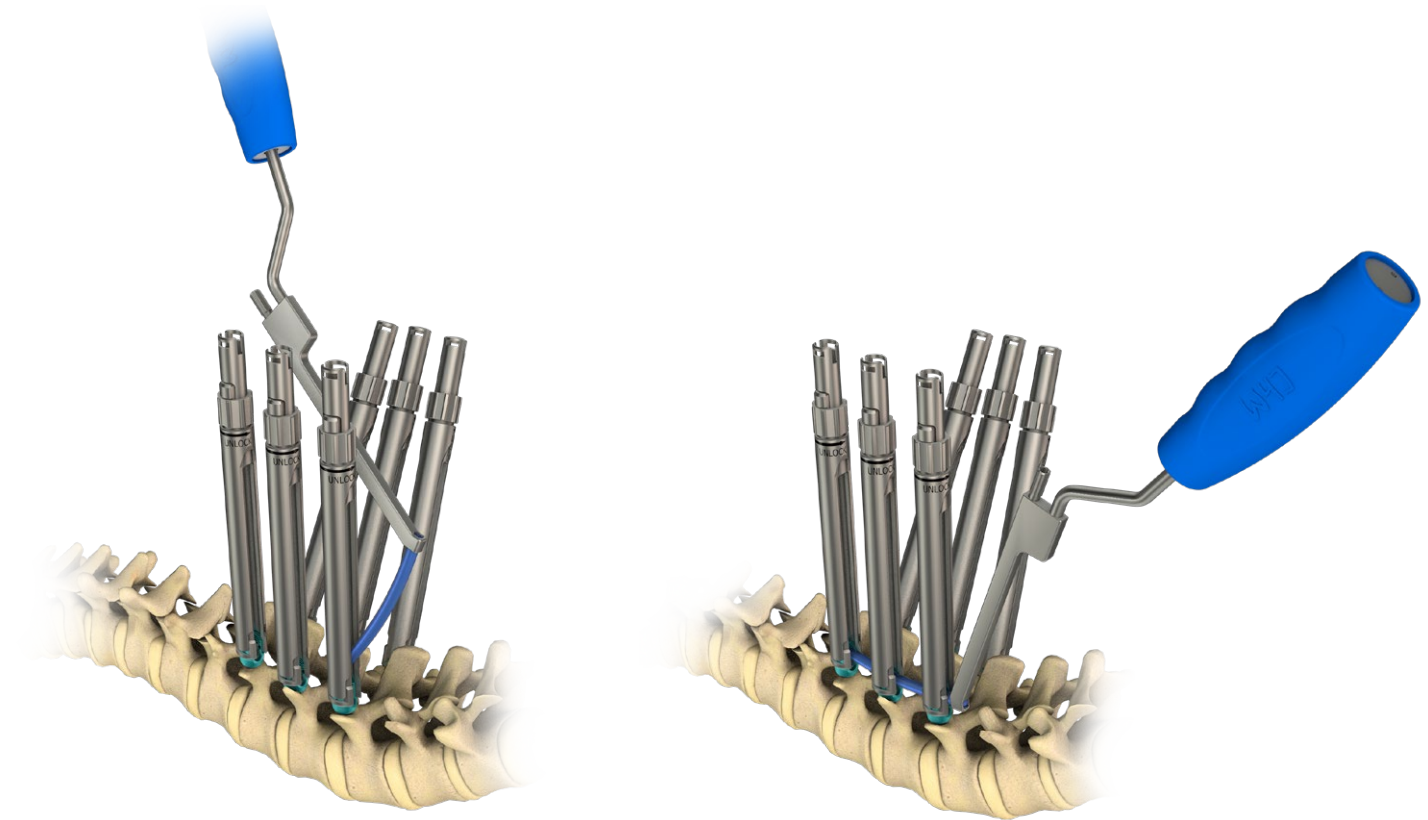

4.10. ROD LOCKING, DISTRACTION, COMPRESSION, FINAL TIGHTENING

4.10.1. ROD LOCKING

Lock the rod by insertion of the locking screw [3.6160.000] into the head of the transpedicular screw.

The locking screw can be attached to the screwdriver T30 tip [40.8574.000] only from the top of the screw (*the design of the locking screw socket prevents fixation in the other way*).

For easier identification, the top surface of the screw is colour-marked.

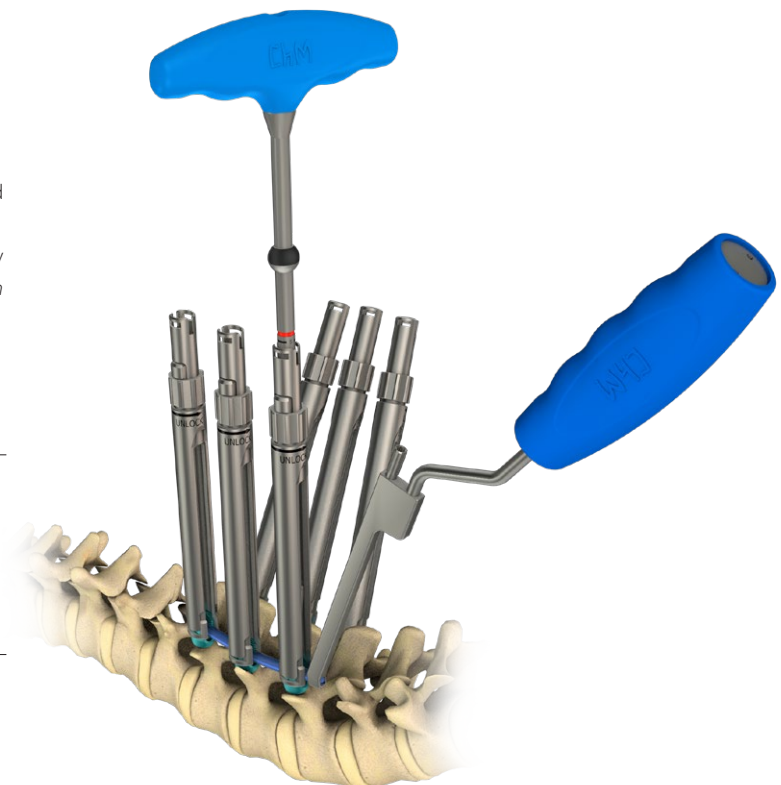
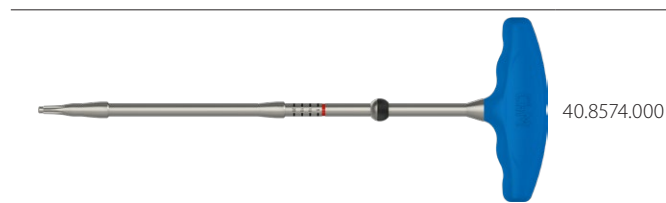

Attach a locking screw to the tip of the screwdriver T30 [40.8574.000], place in the cutout of the screw head and slightly tighten clockwise.



At this stage, the locking screw should only be slightly tightened, allowing the polyaxial screws to adapt to the shape of the rod.

Should it be difficult to press the rod to the bottom of the screw, use the rod impactor [40.8573.000] available in the instrument set.

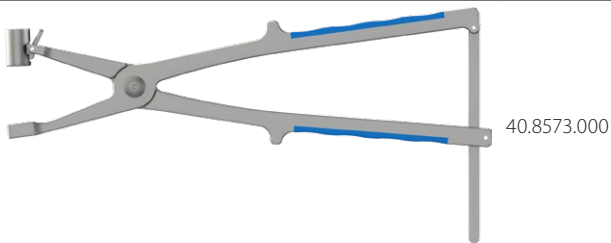

To do this, attach the snap sleeve of the impactor to the guide sleeve [40.8569.000].

Assure the notches in the guide sleeve are corresponding with protrusions in the snap sleeve. Install the snap sleeve until it clicks in the hole of the guide sleeve.

Then, place the arm with the ball socket on the ball located on the shaft of the screwdriver T30 [40.8574.000] and push the arms towards each other to position the rod at the bottom of the screw. Observe the location of the red mark on the screwdriver tip.

When the red marker is at the height of the edge of the guide sleeve, the locking screw contacts the upper surface of the screw head.

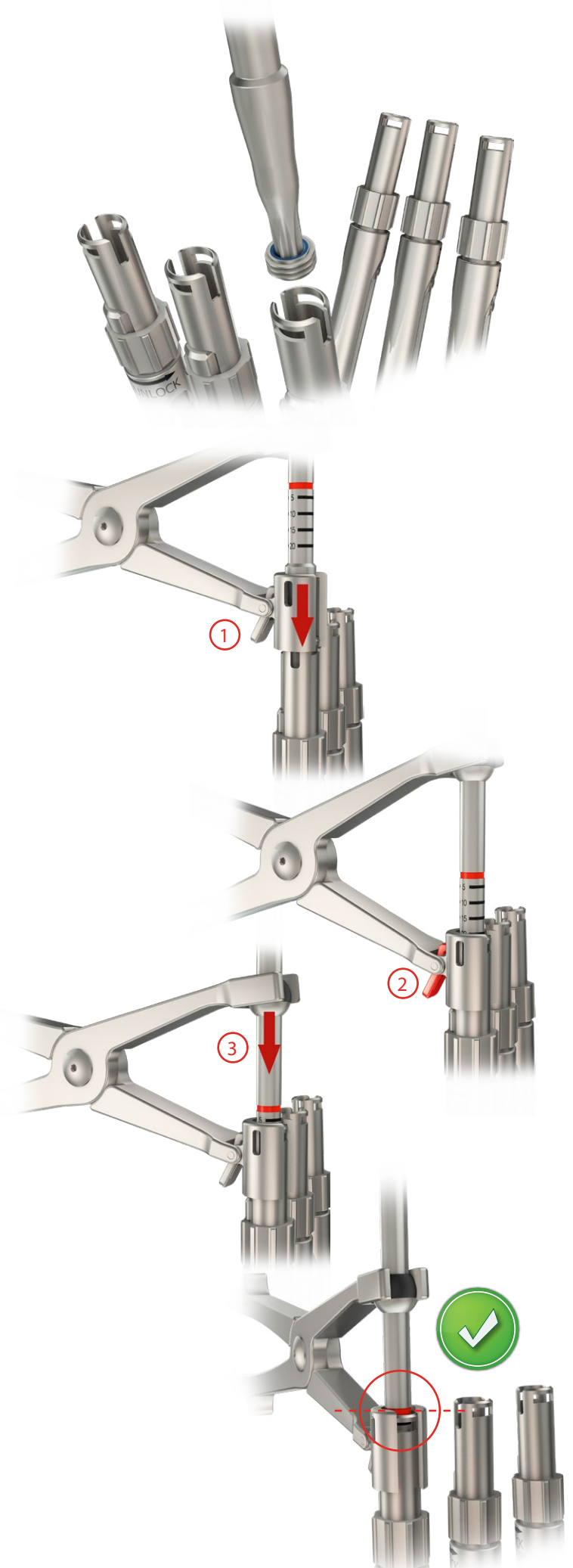



To pre-lock the screw, squeeze the arms of the rod impactor again while tightening up the locking screw.

Check the position of the red mark on the screwdriver tip.

When the marker penetrates about 5mm inside the guide sleeve, the locking screw is tightened up in the screw head.

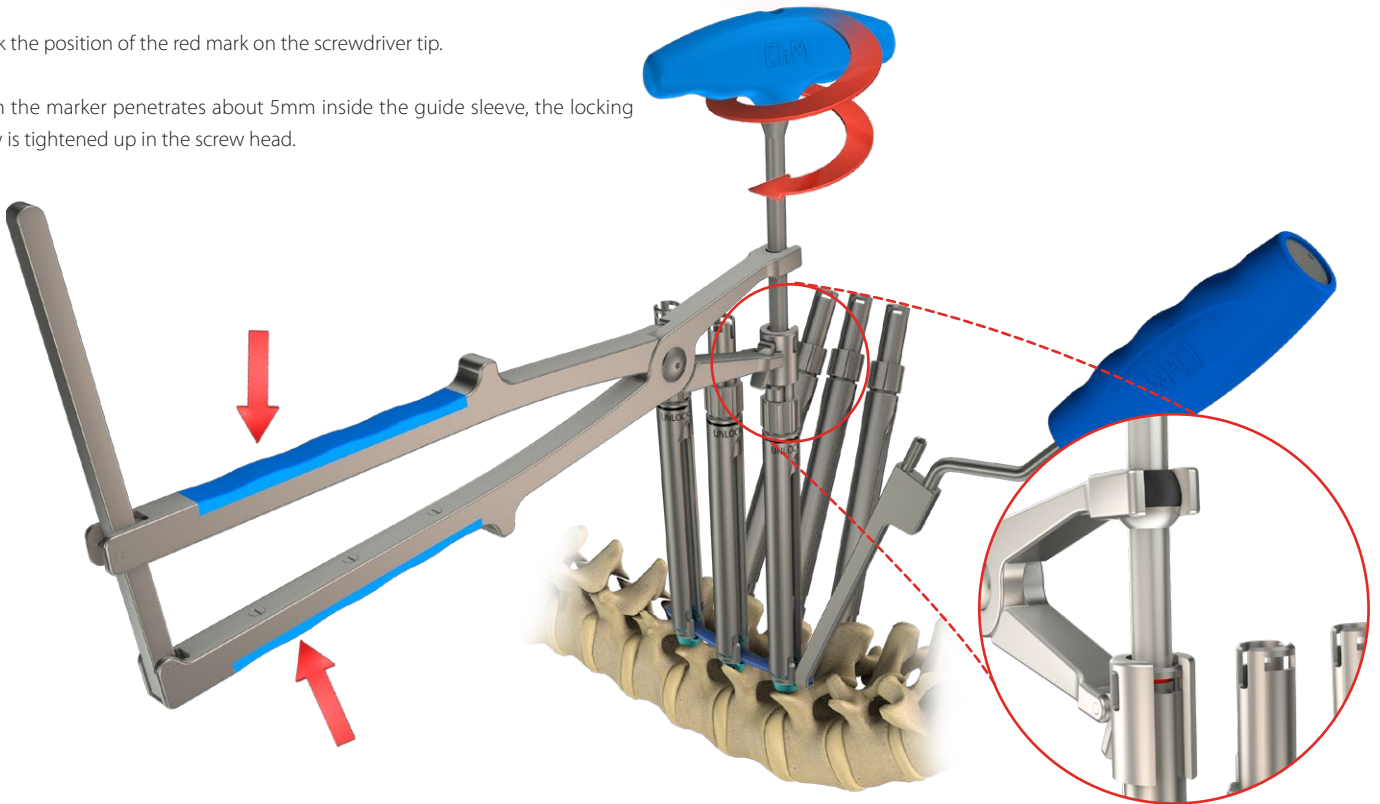

Should it be difficult to push the rod in and tighten the locking screw up, loosen slightly the locking screws in a row, allowing the head of the polyaxial screws to match the rod shape and facilitating tightening of the problematic locking screw.



Excessive distance between the rod and the screw head may result in excessive axial force acting on the screw and, consequently, pulling the screw out of the vertebral bone. Re-shaping of the rod should be considered.

After initial tightening, in order to remove the rod impactor [40.8573.000], unlock the toothed bar, extend the arms sufficiently so that it is possible to easily remove the arm with the ball socket and turn the entire instrument downwards. Turning the impactor downwards releases the snap and allow the device to be removed from the guide sleeve [40.8569.000]. If it is not possible to turn the impactor downwards, use the other hand and release the snap with a finger. Finally, remove the screwdriver T30 [40.8574.000].

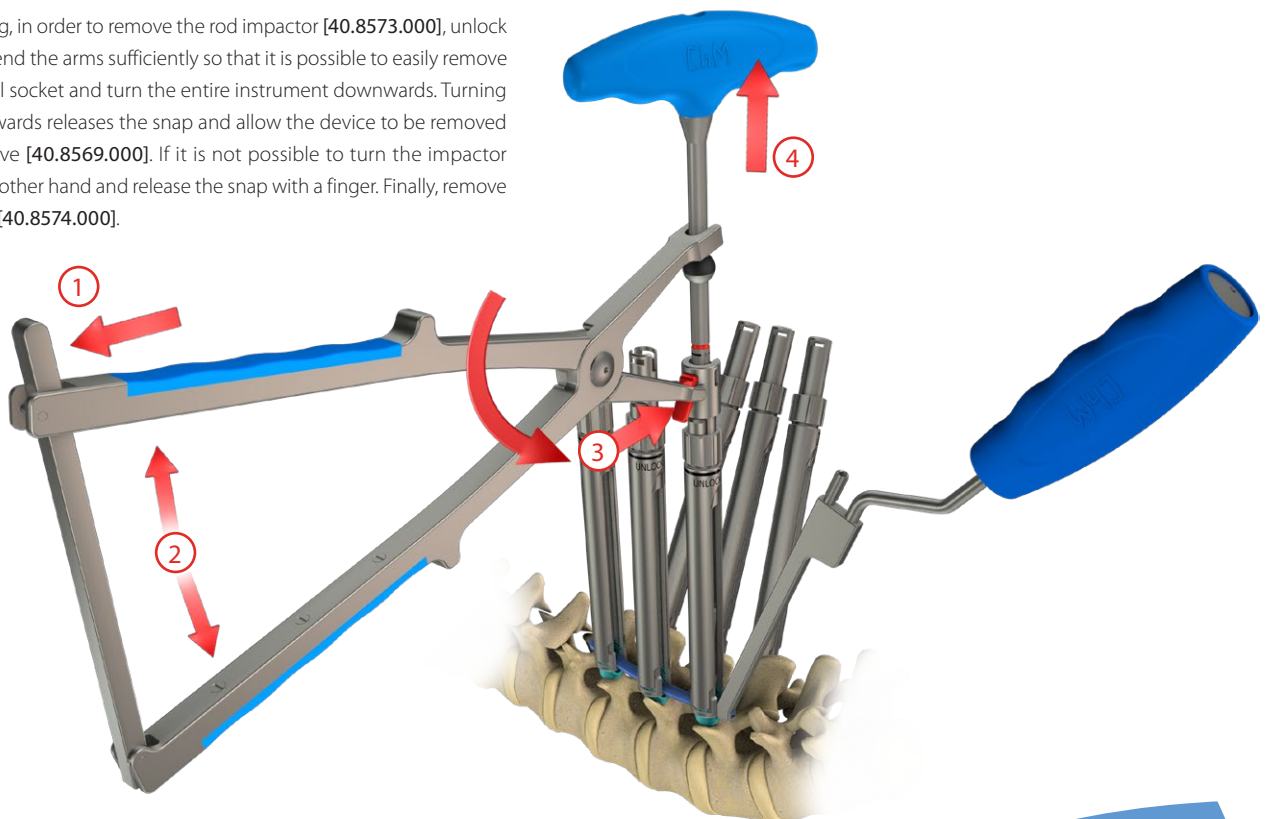

4.10.2. DISTRACTION, COMPRESSION

If distraction or compression of the intervertebral spaces is necessary, use parallel compression forceps [40.8576.000] or parallel distraction forceps [40.8577.000] that enable translations of the vertebrae. To do this, place guides II [40.8575.000] on the guide sleeves [40.8569.000] and then attach appropriate forceps

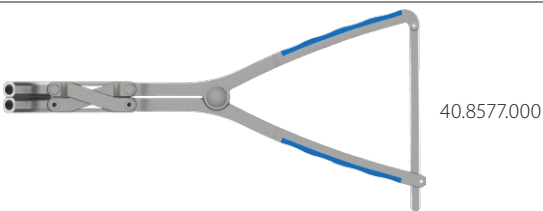
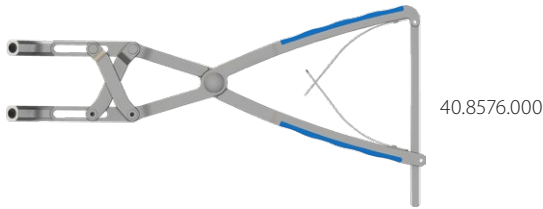
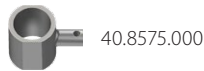

When distraction over a long distance is required (e.g. to decompress a broken vertebra), use the connector [40.8595.000] that is not included in the standard instrument set.



Place the reposition plate [40.8578.000] on the ends of the guide sleeves so that the largest hole in the plate is always used. Push the forceps levers toward each other to displace the vertebrae (distraction or compression depending on the forceps used).

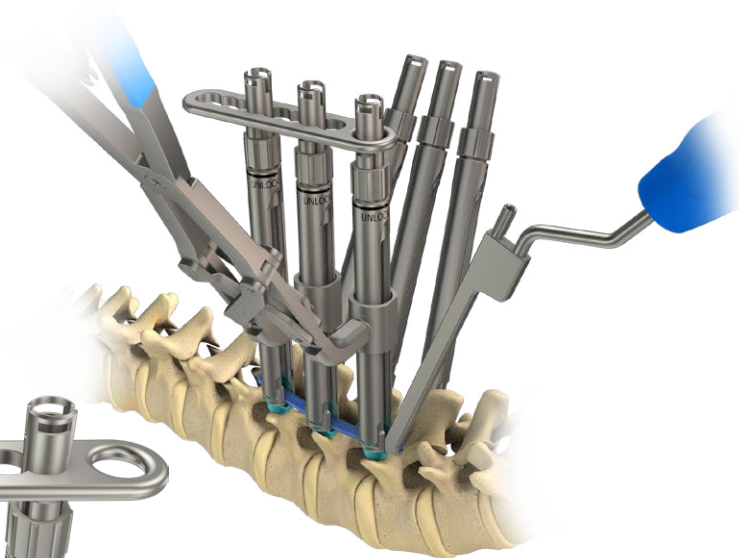
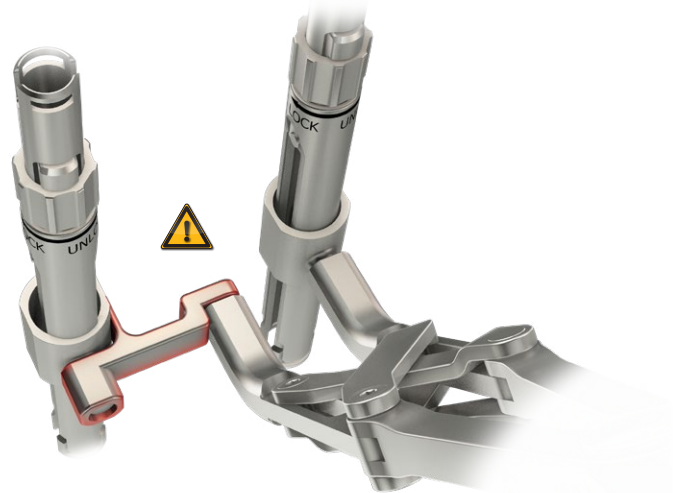

4.10.3. FINAL LOCKING

When the required position of the vertebrae is reached, tighten finally the locking screws using T-type torque handle 12Nm [40.8087.000] and screwdriver tip T30 [40.8084.000]. When the required torque of 12Nm is reached, the dynamometric mechanism signals it with an audible snap.

To eliminate the movements of rod-screws system while tightening the locking elements, use the counter wrench [40.8579.000] that is attached to the notches in the guide sleeve [40.8569.000].

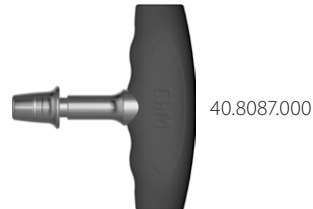
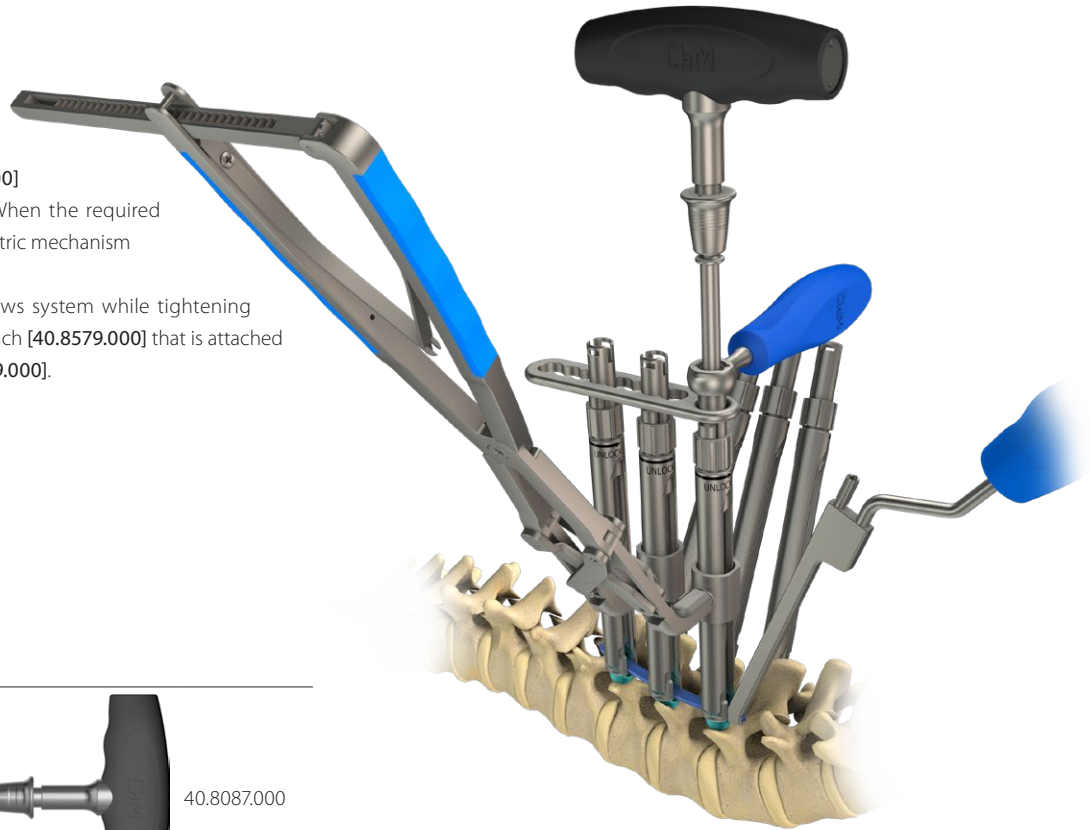

40.8087.000



40.8084.000



40.8579.000



In order to maintain high safety and correct operation of the torque wrench [40.8087.000], follow the calibration deadline which is permanently marked on the instrument. The instrument calibration is performed by the manufacturer - ChM sp. z o.o.

If it is necessary to unscrew the locking screw, use screwdriver T30 [40.8111.000]. The tip of this screwdriver (*unlike 40.8574.000*) does not have a pilot. Such a design allows the instrument to be fully inserted in the locking screw socket reducing the risk of losing the locking screw inside the guide sleeve.



40.8111.000

Having final tightened the locking screw and assured that the stabilization has been performed as planned, the applicator [40.8571.000] or [40.8572.000] and guide sleeves [40.8569.000] can be removed. To remove the guide sleeve, turn the sleeve wheel all the way in the UNLOCK direction, pull and remove the sleeve from the screw.



If it is difficult to loosen the locking pin of the applicator [40.8571.000] or [40.8572.000], insert the tip of the wrench for polyaxial screws [40.8568.000] with oval head ratchet handle [40.8086.000] into the pin socket and loosen it.



If it is difficult to loosen the sleeve wheel, use the wrench [40.8580.000].



40.8580.000

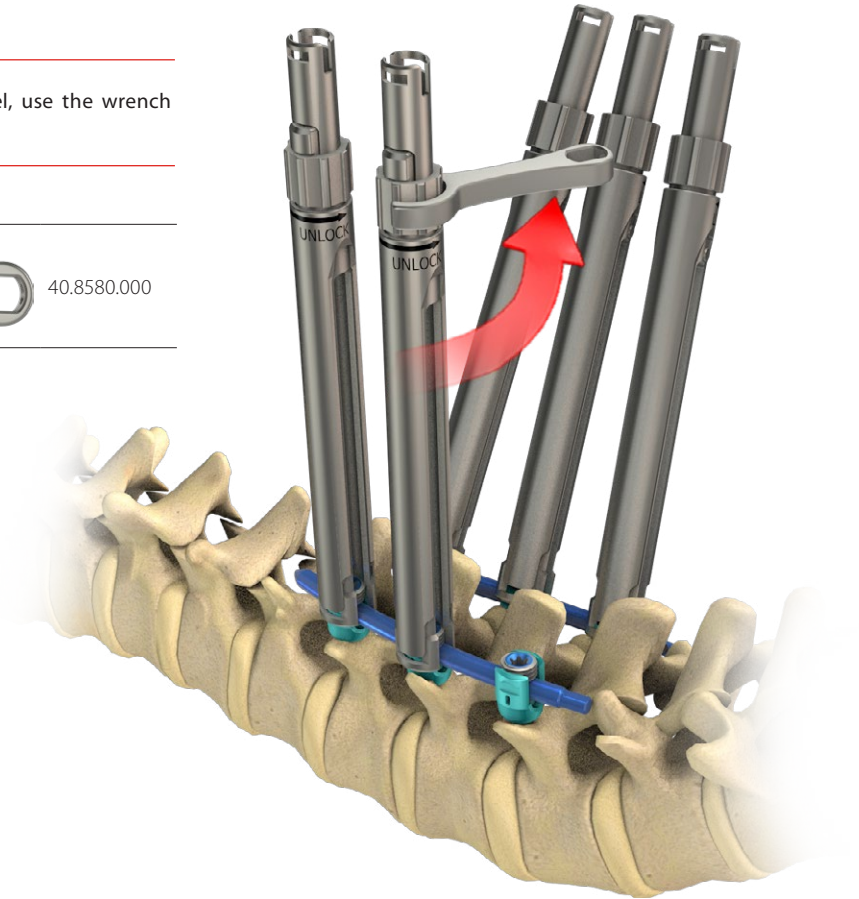

5. REVISION SURGERY

The design of the guide sleeves [40.8569.000] allows them to be re-attached to the already implanted screws.

To facilitate centering of the sleeve with the screw, use screwdriver tip T30 [40.8084.000] entered through the guide sleeve [40.8569.000] and then insert the tip into the socket of the implanted locking screw.

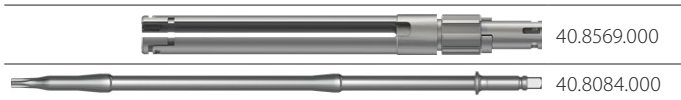

Then slide the sleeve onto the screw and follow the instructions in section 4.6.4. After mounting the sleeve, the screwdriver tip T30 [40.8084.000] can be removed.

If it is necessary to unscrew the locking screw, use screwdriver T30 [40.8111.000]. The tip of this screwdriver (*unlike 40.8574.000*) does not have a pilot. Such a design allows the instrument to be fully inserted in the locking screw socket reducing the risk of losing the locking screw inside the guide sleeve.

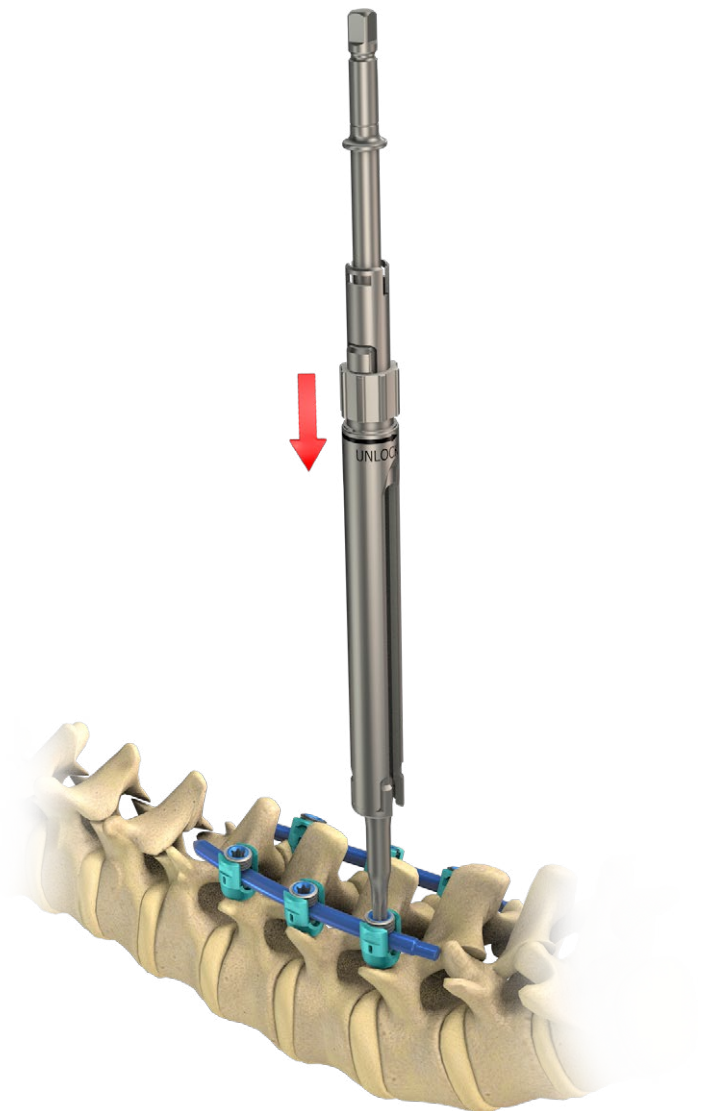

ChM sp. z o.o.

Lewickie 3b
16-061 Juchnowiec Kościelny
Polska

tel. +48 85 86 86 100

fax +48 85 86 86 101

chm@chm.eu

www.chm.eu



CE 0197