

CHM[®]

CHARSPINE *system 2*

SPINE STABILIZATION

- *IMPLANTS*
- *INSTRUMENT SET 40.8800.000*
- *SURGICAL TECHNIQUE*



SYMBOLS DESCRIPTION



Caution - pay attention to a special procedure.



Perform the activity under X-Ray control.



Information about the next stages of a procedure.



Proceed to the next stage.



Return to the specified stage and repeat the activity.



Before using the product, carefully read the Instructions for Use. It contains, among others, indications, contraindications, side effects, recommendations and warnings related to the use of the product.



The above description is not a detailed instruction of conduct. The surgeon decides about choosing the operating procedure.

www.chm.eu

Document No ST/99A
Date of issue 03.02.2021
Review date P-002-05.04.2023

The manufacturer reserves the right to introduce design changes.

Updated INSTRUCTIONS FOR USE are available at the following website: ifu.chm.eu

1. INTRODUCTION	5
2. IMPLANTS	8
3. INSTRUMENTS	24
3.1. CONTAINERS ARRANGEMENT	28
4. SURGICAL TECHNIQUE	29
4.1. THORACOTOMY	29
4.2. ANTERIOR THORACOLUMBAR APPROACH	30
4.3. ANTERIOR RETROPERITONEAL APPROACH	30
4.4. POSTERIOR APPROACH TO THE THORACOLUMBAR APPROACH	31
4.5. APPROACH TO POSTERIOR SUPERIOR ILIAC SPINE	31
4.6. SCREW SELECTION. PREPARATION OF THE SCREW ENTRY POINT	32
4.7. INSERTION OF SCREWS. POSTERIOR APPROACH	33
4.8. INTRODUCTION OF POLYAXIAL SCREWS INTO THE PELVIS	45
4.9. IMPLANT REMOVAL	47
4.10. CEMENT AUGMENTATION OF SCREWS (<i>OPTIONAL</i>)	48

1. INTRODUCTION

CHARSPINE2 Thoracolumbar Spinal Stabilization System is the set of universal spinal fixation implants for thoracolumbar and lumbar spine treatment in skeletally mature patients:

- via posterior approach
 - screw fixation from T1 (T3) to S2
 - hook fixation from T1 (T3) to L5
- via anterolateral approach
 - screw fixation from T4 (T6) to L4 (L3)

CHARSPINE2 system consists of:

- implants (*screws, hooks, connectors, locking elements, staples, and others*),
- instruments for implants insertion,
- instructions for use and surgical technique.

INDICATIONS

CHARSPINE2 implants allow for treatment intended for spinal physiological curvature reconstruction by means of appropriate vertebrae reposition.

Indications for use:

- degenerative disc disease,
- spondylolistheses,
- fractures and instabilities,
- deformities (*e.g. scolioses or kyphoses*),
- tumours,
- stenoses,
- pseudoarthroses,
- nonunion following the previous procedures.

CONTRAINDICATIONS

Contraindications may be relative and absolute. One should thoroughly consider the selection of an appropriate implant on the basis of comprehensive assessment of patient's health condition. Some conditions such as spinal infection, morbid obesity, mental disease, alcohol or drug addiction, pregnancy, oversensitivity to metals/foreign bodies, insufficient tissue coverage or open wound in the operative site may reduce the chances of surgery or make the success impossible.



A detailed list of contraindications is presented in instructions for use (IFU) intended for this device.

WARNINGS

Safety and effectiveness of spinal systems based upon pedicle screw fixation have been established only for pathological spinal conditions caused by significant mechanical instability or deformations requiring surgical fixation. Safety and effectiveness of these systems for any other conditions are unknown.

It is not always possible to achieve positive results in each and every patient. This especially applies to procedures in which other conditions related to patient's state may make it impossible to achieve the positive results.

The final result is greatly influenced by appropriate patient selection and patient's observance of postoperative recommendations. It is proved that smoking hampers the bone union. Patients should be informed about this correlation and warned about the consequences.



A detailed list of warnings, precautions and postoperative recommendations is presented in instructions for use (IFU) intended for this device.





Implants from the ChM CHARSPINE2 spine stabilization system are designed and tested to be used only with the appropriate ChM instrument set. This surgical technique is intended as a guide only. As with any surgical procedure, the surgeon should be thoroughly trained before the procedure and must take into consideration the particular needs of each patient.

MAIN FEATURES AND BENEFITS

Presented implants and instrument set are intended for posterior and anterolateral approach.

The presented range of implants is made of titanium, titanium alloys and cobalt alloy in accordance with ISO 5832 standards.

To avoid errors, it is possible to connect the screw with the screwdriver from one side only.

The same locking screw for all types of screws and hooks.

Low profile of the screw head reduces the irritation of adjacent soft tissue.

Double thread for more stable anchoring in the cortex of the vertebra.

The centering cone and the sharper, self-tapping thread profile facilitates easier screw insertion.

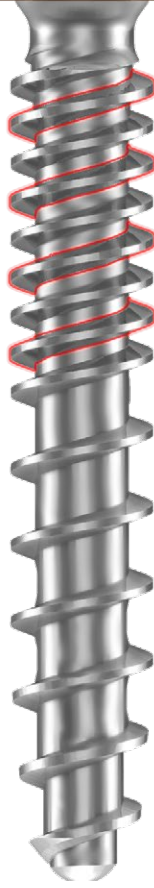
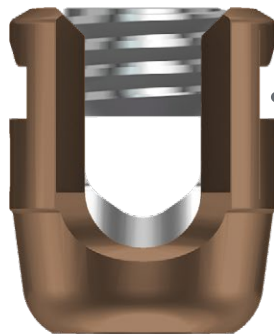
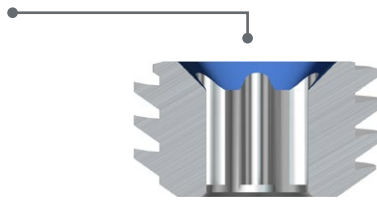

Trapezoidal, asymmetrical thread of the locking screw ensures high strength and prevents thread skewing.

Undercut thread profile prevents head arms drawing aside by directing the reaction forces into the screw interior.

Upper location of fixation cut-outs facilitates the fixation and use of persuaders intended for rod impaction.

Screw head compatible with percutaneous sleeves of the CHARSPINE2 MIS system.

Cylindrical part

Atraumatic end



The screws with a double thread of CHARSPINE2 system are compatible with the instrument set 15.0913 for minimally invasive technique (MIS). Should these screws be introduced using percutaneous method (without the use of a guide rod), please refer to the surgical technique No. ST-86, intended for the CHARSPINE2 MIS system.

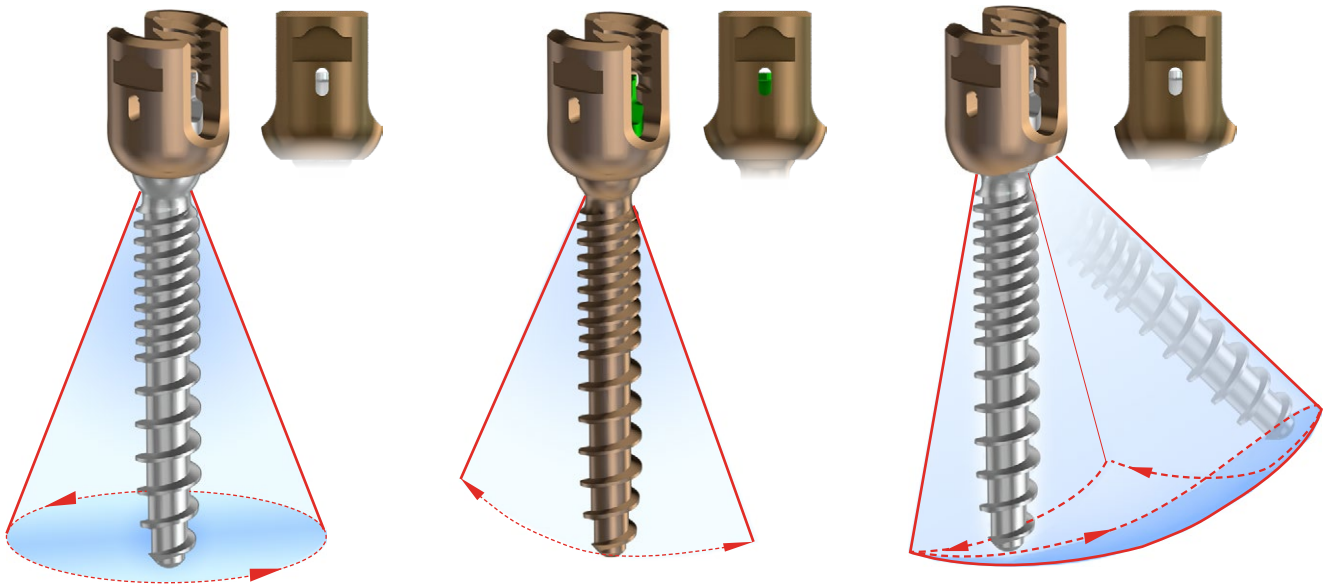

Polyaxial screws allow for stable angular fixation of the screw head in each direction.

Uniplanar screws combine the features of medial-lateral stiffness of monoaxial screws with the mobility of polyaxial screws in the rostral-caudal direction.

Polyaxial screws for pelvis allow for the extension of thoracolumbar spine stabilization and fixation in the pelvic bone. The screws offer an increased asymmetrical range of motion in one of the planes, facilitating the rod-to-screw fixation.

A new generation of surgical instruments was prepared for **CHARSPINE2** system, aiming at maximization of their ergonomics, functionality and effectiveness.

The instruments have original **ChM** branded silicon handles that improve the ergonomics and comfort of a grip.

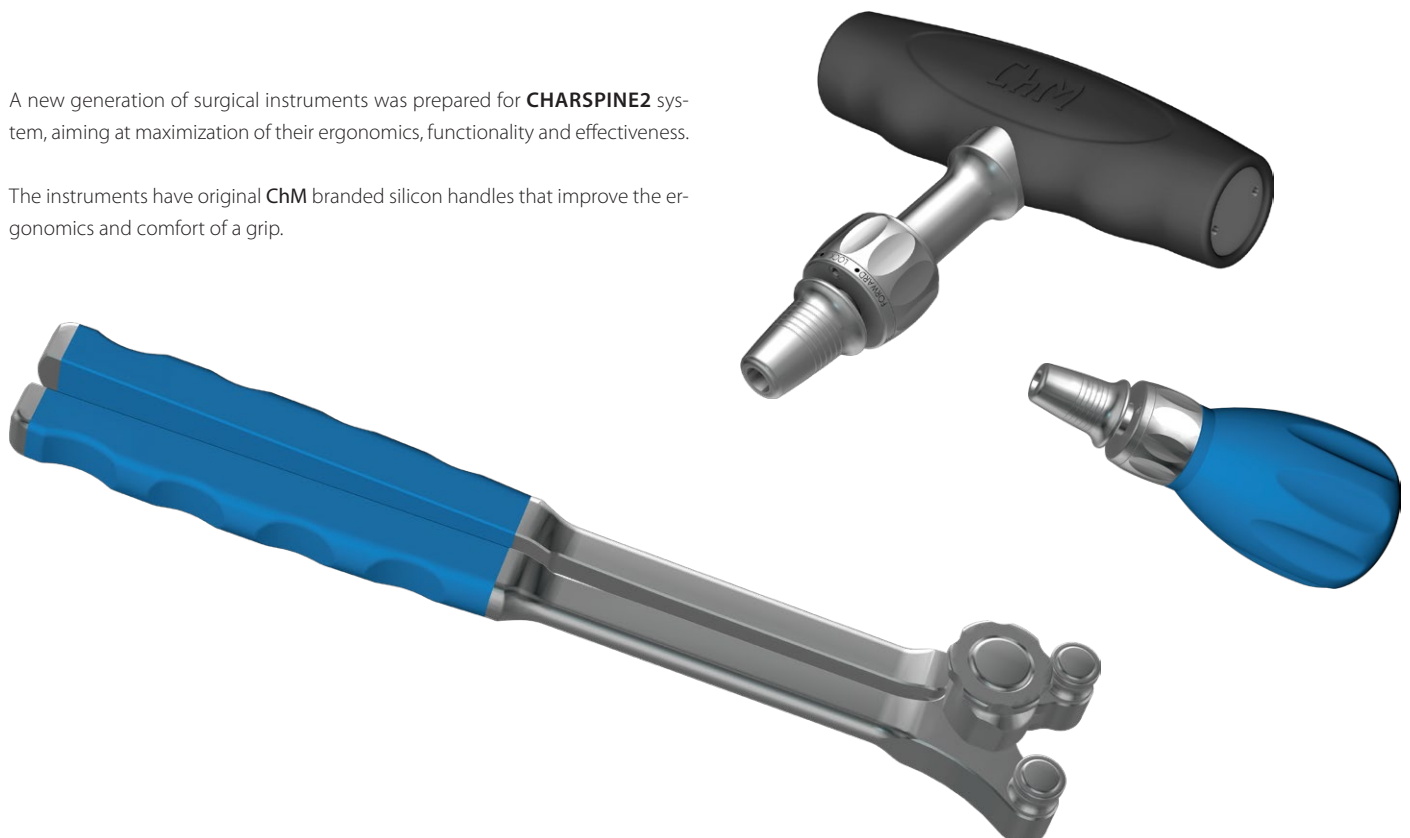

2. IMPLANTS

CHARSPINE2 MONOAXIAL SCREW

CHARSPINE system 2

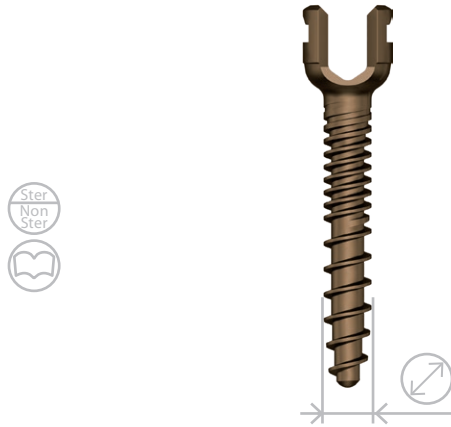

	Len	Ti		Len	Ti
4.0	25	3.6150.525	8.5	25	3.6157.525
	30	3.6150.530		30	3.6157.530
	35	3.6150.535		35	3.6157.535
	40	3.6150.540		40	3.6157.540
	45	3.6150.545		45	3.6157.545
4.5	25	3.6151.525	9.5	50	3.6157.550
	30	3.6151.530		55	3.6157.555
	35	3.6151.535		60	3.6157.560
	40	3.6151.540		65	3.6157.565
	45	3.6151.545		70	3.6157.570
5.0	25	3.6152.525	10.5	75	3.6157.575
	30	3.6152.530		80	3.6157.580
	35	3.6152.535		85	3.6157.585
	40	3.6152.540		90	3.6157.590
	45	3.6152.545		95	3.6157.595
5.5	50	3.6152.550	10.5	100	3.6157.601
	25	3.6153.525		25	3.6158.525
	30	3.6153.530		30	3.6158.530
	35	3.6153.535		35	3.6158.535
	40	3.6153.540		40	3.6158.540
6.0	45	3.6153.545	10.5	45	3.6158.545
	50	3.6153.550		50	3.6158.550
	55	3.6153.555		55	3.6158.555
	25	3.6154.525		60	3.6158.560
	30	3.6154.530		65	3.6158.565
6.5	35	3.6154.535	10.5	70	3.6158.570
	40	3.6154.540		75	3.6158.575
	45	3.6154.545		80	3.6158.580
	50	3.6154.550		85	3.6158.585
	55	3.6154.555		90	3.6158.590
7.0	60	3.6154.560	10.5	95	3.6158.595
	65	3.6154.565		100	3.6158.601
	25	3.6155.525		25	3.6159.525
	30	3.6155.530		30	3.6159.530
	35	3.6155.535		35	3.6159.535
7.5	40	3.6155.540	10.5	40	3.6159.540
	45	3.6155.545		45	3.6159.545
	50	3.6155.550		50	3.6159.550
	55	3.6155.555		55	3.6159.555
	60	3.6155.560		60	3.6159.560
8.0	65	3.6155.565	10.5	65	3.6159.565
	70	3.6155.570		70	3.6159.570
	75	3.6155.575		75	3.6159.575
	80	3.6155.580		80	3.6159.580
	85	3.6155.585		85	3.6159.585
8.5	90	3.6155.590	10.5	90	3.6159.590
	95	3.6155.595		95	3.6159.595
	100	3.6155.601		100	3.6159.601

CHARSPINE2 LOCKING SCREW

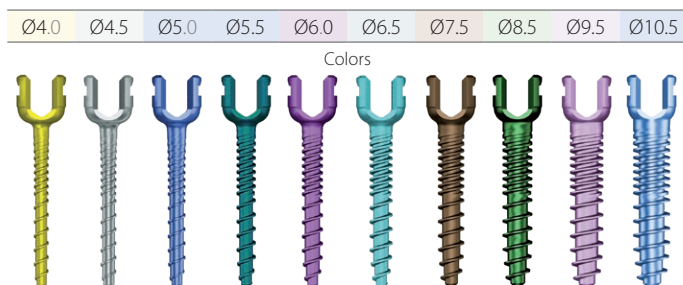
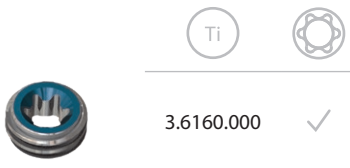

CHARSPINE2 MONOAXIAL REDUCTION SCREW

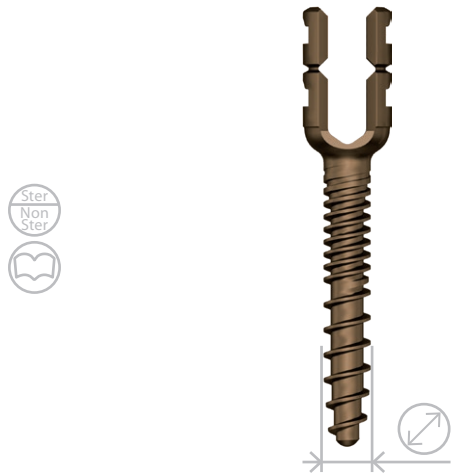

CHARSPINE2 LOCKING SCREW

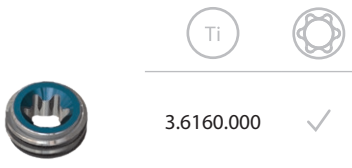

3.6160.000 ✓



For cortical taps used with double-threaded screws to be included in the standard instrument set for CHARSPINE2 spine stabilization [15.0907.001], please contact your local representative or the ChM Sales Department.

Ø4.0 Ø4.5 Ø5.0 Ø5.5 Ø6.0 Ø6.5 Ø7.5 Ø8.5 Ø9.5 Ø10.5

Colors



Len	Ti	Len	Ti	
25	3.6161.525	25	3.6168.525	
30	3.6161.530	30	3.6168.530	
4.0	35	3.6161.535	35	3.6168.535
	40	3.6161.540	40	3.6168.540
	45	3.6161.545	45	3.6168.545
	50	3.6161.550	50	3.6168.550
4.5	30	3.6162.530	55	3.6168.555
	35	3.6162.535	60	3.6168.560
	40	3.6162.540	65	3.6168.565
	45	3.6162.545	70	3.6168.570
	50	3.6162.550	75	3.6168.575
5.0	25	3.6163.525	80	3.6168.580
	30	3.6163.530	85	3.6168.585
	35	3.6163.535	90	3.6168.590
	40	3.6163.540	95	3.6168.595
	45	3.6163.545	100	3.6168.601
	50	3.6163.550	25	3.6169.525
5.5	25	3.6164.525	30	3.6169.530
	30	3.6164.530	35	3.6169.535
	35	3.6164.535	40	3.6169.540
	40	3.6164.540	45	3.6169.545
	45	3.6164.545	50	3.6169.550
	50	3.6164.550	55	3.6169.555
6.0	55	3.6164.555	60	3.6169.560
	25	3.6165.525	65	3.6169.565
	30	3.6165.530	70	3.6169.570
	35	3.6165.535	75	3.6169.575
	40	3.6165.540	80	3.6169.580
	45	3.6165.545	85	3.6169.585
	50	3.6165.550	90	3.6169.590
	55	3.6165.555	95	3.6169.595
	60	3.6165.560	100	3.6169.601
	65	3.6165.565	25	3.6149.525
6.5	25	3.6166.525	30	3.6149.530
	30	3.6166.530	35	3.6149.535
	35	3.6166.535	40	3.6149.540
	40	3.6166.540	45	3.6149.545
	45	3.6166.545	50	3.6149.550
	50	3.6166.550	55	3.6149.555
	55	3.6166.555	60	3.6149.560
	60	3.6166.560	65	3.6149.565
	65	3.6166.565	70	3.6149.570
	70	3.6166.570	75	3.6149.575
7.5	75	3.6166.575	80	3.6149.580
	25	3.6167.525	85	3.6149.585
	30	3.6167.530	90	3.6149.590
	35	3.6167.535	95	3.6149.595
	40	3.6167.540	100	3.6149.601
	45	3.6167.545		
	50	3.6167.550		
	55	3.6167.555		
	60	3.6167.560		
	65	3.6167.565		
70	3.6167.570			
75	3.6167.575			
80	3.6167.580			
85	3.6167.585			
90	3.6167.590			

CHARSPINE2 POLYAXIAL SCREW

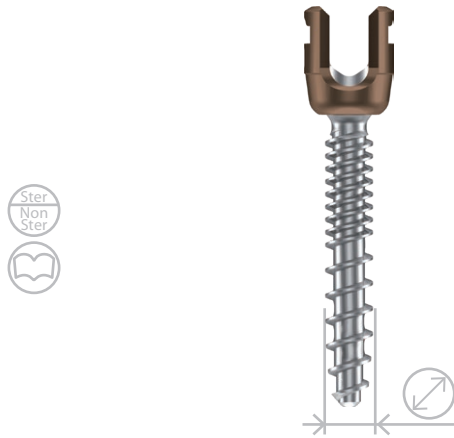

	Len	Ti
4.0	25	3.6170.525
	30	3.6170.530
	35	3.6170.535
	40	3.6170.540
	45	3.6170.545
	50	3.6170.550
4.5	25	3.6171.525
	30	3.6171.530
	35	3.6171.535
	40	3.6171.540
	45	3.6171.545
	50	3.6171.550
5.0	25	3.6172.525
	30	3.6172.530
	35	3.6172.535
	40	3.6172.540
	45	3.6172.545
	50	3.6172.550
5.5	25	3.6173.525
	30	3.6173.530
	35	3.6173.535
	40	3.6173.540
	45	3.6173.545
	50	3.6173.550
6.0	25	3.6174.525
	30	3.6174.530
	35	3.6174.535
	40	3.6174.540
	45	3.6174.545
	50	3.6174.550
6.5	25	3.6175.525
	30	3.6175.530
	35	3.6175.535
	40	3.6175.540
	45	3.6175.545
	50	3.6175.550
7.0	25	3.6176.525
	30	3.6176.530
	35	3.6176.535
	40	3.6176.540
	45	3.6176.545
	50	3.6176.550
7.5	55	3.6176.555
	60	3.6176.560
	65	3.6176.565
	70	3.6176.570
	75	3.6176.575
	80	3.6176.580
8.0	85	3.6176.585
	90	3.6176.590

	Len	Ti	
8.5	25	3.6530.525	
	30	3.6530.530	
	35	3.6530.535	
	40	3.6530.540	
	45	3.6530.545	
	50	3.6530.550	
9.0	55	3.6530.555	
	60	3.6530.560	
	65	3.6530.565	
	70	3.6530.570	
	75	3.6530.575	
	80	3.6530.580	
9.5	85	3.6530.585	
	90	3.6530.590	
	95	3.6530.595	
	100	3.6530.600	
	10.0	25	3.6531.525
		30	3.6531.530
35		3.6531.535	
40		3.6531.540	
45		3.6531.545	
50		3.6531.550	
10.5	55	3.6531.555	
	60	3.6531.560	
	65	3.6531.565	
	70	3.6531.570	
	75	3.6531.575	
	80	3.6531.580	
11.0	85	3.6531.585	
	90	3.6531.590	
	95	3.6531.595	
	100	3.6531.600	
	11.5	25	3.6532.525
		30	3.6532.530
35		3.6532.535	
40		3.6532.540	
45		3.6532.545	
50		3.6532.550	
12.0	55	3.6532.555	
	60	3.6532.560	
	65	3.6532.565	
	70	3.6532.570	
	75	3.6532.575	
	80	3.6532.580	
12.5	85	3.6532.585	
	90	3.6532.590	
	95	3.6532.595	
	100	3.6532.600	

CHARSPINE2 LOCKING SCREW

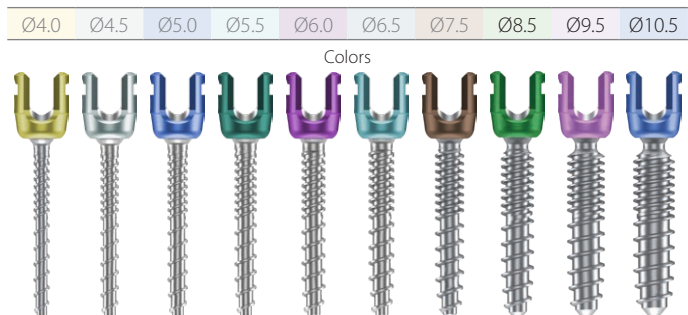
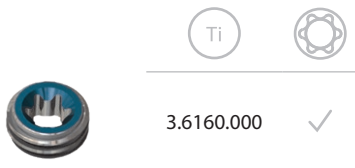

CHARSPINE2 POLYAXIAL REDUCTION SCREW

CHARSPINE system 2

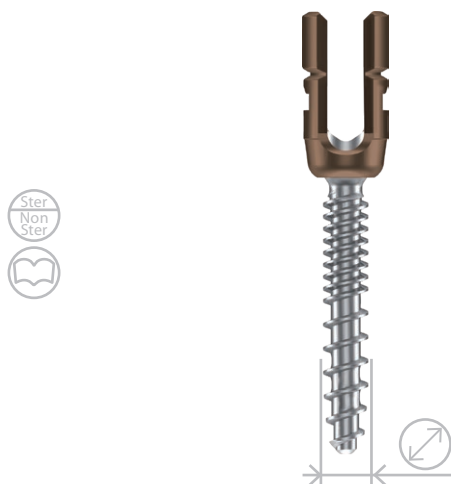

	Len	Ti		Len	Ti	
4.0	25	3.6177.525	8.5	25	3.6533.525	
	30	3.6177.530		30	3.6533.530	
	35	3.6177.535		35	3.6533.535	
	40	3.6177.540		40	3.6533.540	
	45	3.6177.545		45	3.6533.545	
4.5	25	3.6178.525	9.5	50	3.6533.550	
	30	3.6178.530		55	3.6533.555	
	35	3.6178.535		60	3.6533.560	
	40	3.6178.540		65	3.6533.565	
	45	3.6178.545		70	3.6533.570	
5.0	20	3.6179.520	10.5	75	3.6533.575	
	25	3.6179.525		80	3.6533.580	
	30	3.6179.530		85	3.6533.585	
	35	3.6179.535		90	3.6533.590	
	40	3.6179.540		95	3.6533.595	
5.5	45	3.6179.545	7.5	100	3.6533.600	
	50	3.6179.550		25	3.6534.525	
	25	3.6180.525		30	3.6534.530	
	30	3.6180.530		35	3.6534.535	
	35	3.6180.535		40	3.6534.540	
6.0	40	3.6180.540	6.5	45	3.6534.545	
	45	3.6180.545		50	3.6534.550	
	50	3.6180.550		55	3.6534.555	
	55	3.6180.555		60	3.6534.560	
	60	3.6180.560		65	3.6534.565	
6.5	65	3.6180.565	6.0	70	3.6534.570	
	25	3.6181.525		75	3.6534.575	
	30	3.6181.530		80	3.6534.580	
	35	3.6181.535		85	3.6534.585	
	40	3.6181.540		90	3.6534.590	
7.0	45	3.6181.545	6.5	95	3.6534.595	
	50	3.6181.550		100	3.6534.600	
	55	3.6181.555		25	3.6535.525	
	60	3.6181.560		30	3.6535.530	
	65	3.6181.565		35	3.6535.535	
7.5	25	3.6182.525	7.0	40	3.6535.540	
	30	3.6182.530		45	3.6535.545	
	35	3.6182.535		50	3.6535.550	
	40	3.6182.540		55	3.6535.555	
	45	3.6182.545		60	3.6535.560	
8.0	50	3.6182.550	7.5	65	3.6535.565	
	55	3.6182.555		70	3.6535.570	
	60	3.6182.560		75	3.6535.575	
	65	3.6182.565		80	3.6183.580	
	25	3.6183.525		85	3.6183.585	
8.5	30	3.6183.530	8.0	90	3.6183.590	
	35	3.6183.535		8.5		
	40	3.6183.540				
	45	3.6183.545				
	50	3.6183.550				
9.0	55	3.6183.555	9.0			
	60	3.6183.560				
	65	3.6183.565				
	70	3.6183.570				
	75	3.6183.575				
9.5	80	3.6183.580	9.5			
	85	3.6183.585				
	90	3.6183.590				

CHARSPINE2 LOCKING SCREW



For cortical taps used with double-threaded screws to be included in the standard instrument set for CHARSPINE2 spine stabilization [15.0907.001], please contact your local representative or the ChM Sales Department.

Ø4.0 Ø4.5 Ø5.0 Ø5.5 Ø6.0 Ø6.5 Ø7.5 Ø8.5 Ø9.5 Ø10.5

Colors



CHARSPINE2 POLYAXIAL SCREW FOR PELVIS

CHARSPINE *system 2*

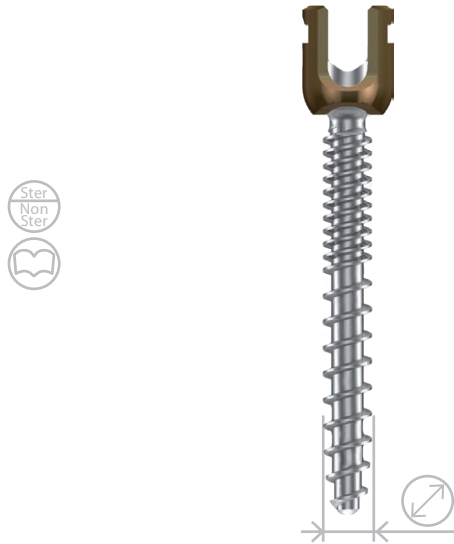

	Len	Ti
6.5	25	3.6514.525
	30	3.6514.530
	35	3.6514.535
	40	3.6514.540
	45	3.6514.545
	50	3.6514.550
	55	3.6514.555
	60	3.6514.560
	65	3.6514.565
	70	3.6514.570
	75	3.6514.575
	80	3.6514.580
7.5	85	3.6514.585
	90	3.6514.590
	25	3.6515.525
	30	3.6515.530
	35	3.6515.535
	40	3.6515.540
	45	3.6515.545
	50	3.6515.550
	55	3.6515.555
	60	3.6515.560
	65	3.6515.565
	70	3.6515.570
75	3.6515.575	
80	3.6515.580	
85	3.6515.585	
90	3.6515.590	

CHARSPINE2 LOCKING SCREW

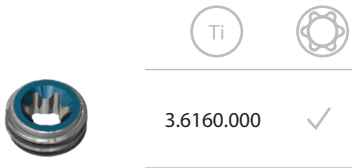

Ø6.5 Ø7.5

Colors

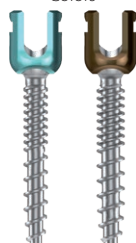

CHARSPINE2 UNIPLANAR SCREW

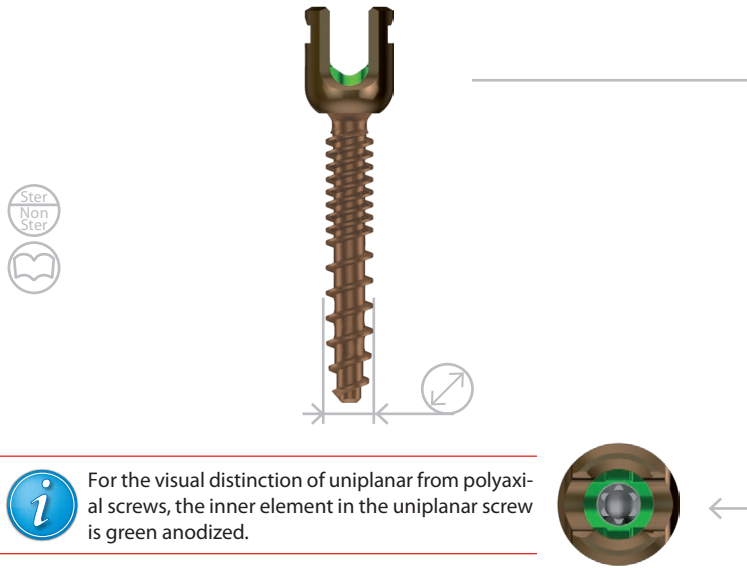

i For the visual distinction of uniplanar from polyaxial screws, the inner element in the uniplanar screw is green anodized.

CHARSPINE2 LOCKING SCREW

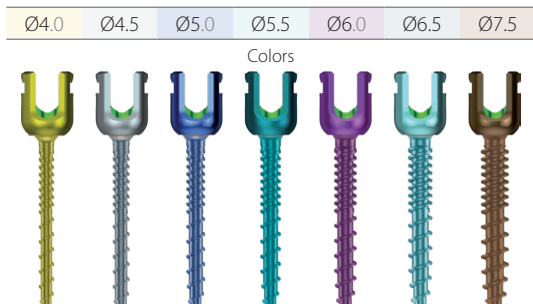
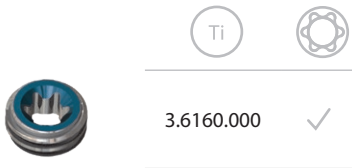

	Len	Ti
4.0	25	3.6184.525
	30	3.6184.530
	35	3.6184.535
	40	3.6184.540
	45	3.6184.545
4.5	25	3.6185.525
	30	3.6185.530
	35	3.6185.535
	40	3.6185.540
	45	3.6185.545
5.0	25	3.6186.525
	30	3.6186.530
	35	3.6186.535
	40	3.6186.540
	45	3.6186.545
5.5	50	3.6186.550
	25	3.6187.525
	30	3.6187.530
	35	3.6187.535
	40	3.6187.540
6.0	45	3.6187.545
	50	3.6187.550
	55	3.6187.555
	25	3.6188.525
	30	3.6188.530
6.5	35	3.6188.535
	40	3.6188.540
	45	3.6188.545
	50	3.6188.550
	55	3.6188.555
7.5	60	3.6188.560
	65	3.6188.565
	25	3.6189.525
	30	3.6189.530
	35	3.6189.535
7.5	40	3.6189.540
	45	3.6189.545
	50	3.6189.550
	55	3.6189.555
	60	3.6189.560
7.5	65	3.6189.565
	25	3.6190.525
	30	3.6190.530
	35	3.6190.535
	40	3.6190.540
7.5	45	3.6190.545
	50	3.6190.550
	55	3.6190.555
	60	3.6190.560
	65	3.6190.565
7.5	70	3.6190.570
	75	3.6190.575
	80	3.6190.580
	85	3.6190.585
	90	3.6190.590

CHARSPINE2 UNIPLANAR REDUCTION SCREW

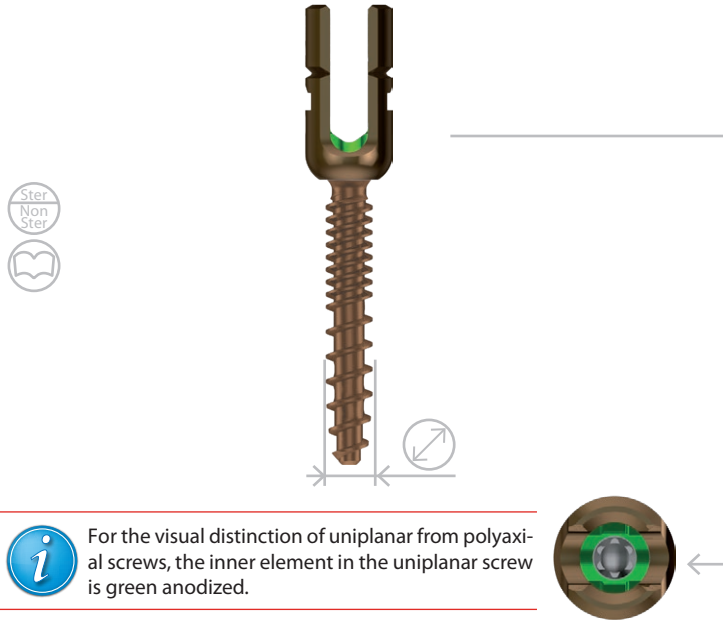

	Len	Ti
4.0	25	3.6191.525
	30	3.6191.530
	35	3.6191.535
	40	3.6191.540
	45	3.6191.545
4.5	25	3.6192.525
	30	3.6192.530
	35	3.6192.535
	40	3.6192.540
	45	3.6192.545
5.0	25	3.6193.525
	30	3.6193.530
	35	3.6193.535
	40	3.6193.540
	45	3.6193.545
5.5	50	3.6193.550
	25	3.6194.525
	30	3.6194.530
	35	3.6194.535
	40	3.6194.540
6.0	45	3.6194.545
	50	3.6194.550
	55	3.6194.555
	25	3.6195.525
	30	3.6195.530
6.5	35	3.6195.535
	40	3.6195.540
	45	3.6195.545
	50	3.6195.550
	55	3.6195.555
7.5	60	3.6195.560
	65	3.6195.565
	25	3.6196.525
	30	3.6196.530
	35	3.6196.535
	40	3.6196.540
	45	3.6196.545
	50	3.6196.550
	55	3.6196.555
	60	3.6196.560
	65	3.6196.565
	25	3.6197.525
	30	3.6197.530
	35	3.6197.535
	40	3.6197.540
	45	3.6197.545
	50	3.6197.550
	55	3.6197.555
	60	3.6197.560
	65	3.6197.565
	70	3.6197.570
	75	3.6197.575
	80	3.6197.580
	85	3.6197.585
	90	3.6197.590

CHARSPINE2 LOCKING SCREW

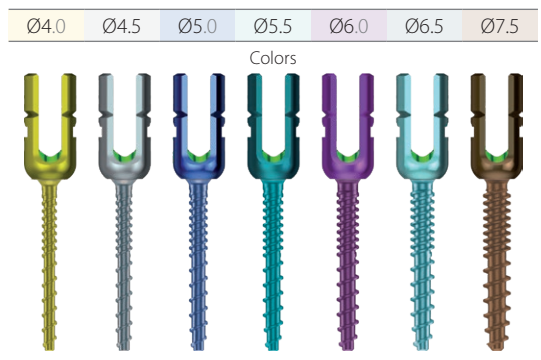

ROD 6

CHARSPINE *system 2*

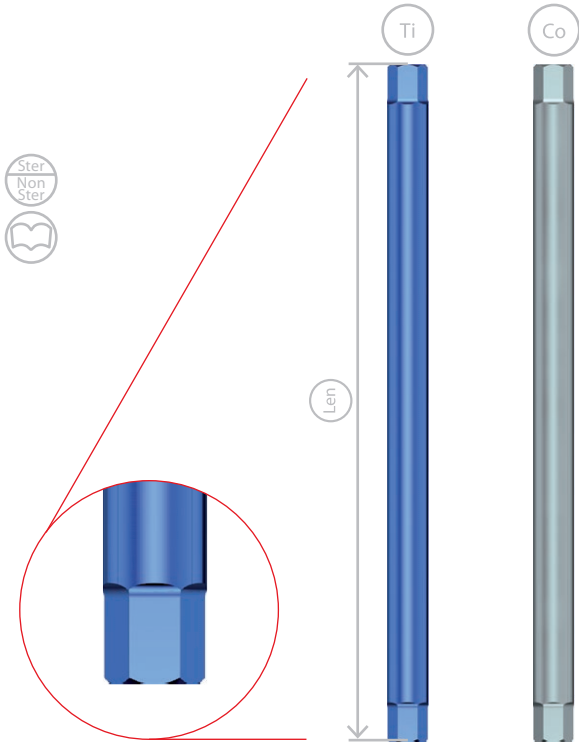

Len	Ti	Co
40	3.3246.040	4.3980.040
50	3.3246.050	4.3980.050
60	3.3246.060	4.3980.060
70	3.3246.070	4.3980.070
80	3.3246.080	4.3980.080
90	3.3246.090	4.3980.090
100	3.3246.100	4.3980.100
120	3.3246.120	4.3980.120
140	3.3246.140	4.3980.140
160	3.3246.160	4.3980.160
180	3.3246.180	4.3980.180
200	3.3246.200	4.3980.200
220	3.3246.220	4.3980.220
260	3.3246.260	4.3980.260
300	3.3246.300	4.3980.300
360	3.3246.360	4.3980.360
400	3.3246.400	4.3980.400
460	3.3246.460	4.3980.460
500	3.3246.500	4.3980.500

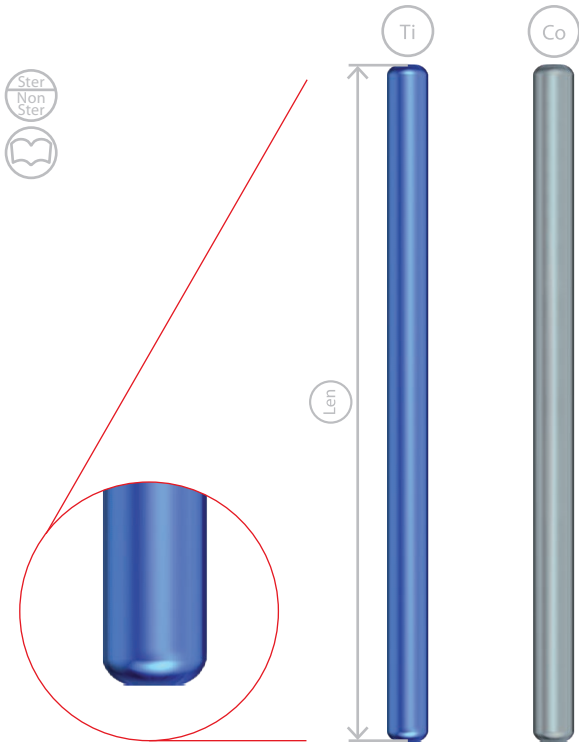

Len	Ti	Co
40	3.3248.040	4.3249.040
50	3.3248.050	4.3249.050
60	3.3248.060	4.3249.060
70	3.3248.070	4.3249.070
80	3.3248.080	4.3249.080
90	3.3248.090	4.3249.090
100	3.3248.100	4.3249.100
120	3.3248.120	4.3249.120
140	3.3248.140	4.3249.140
160	3.3248.160	4.3249.160
180	3.3248.180	4.3249.180
200	3.3248.200	4.3249.200

CURVED ROD 6

CHARSPINE system 2

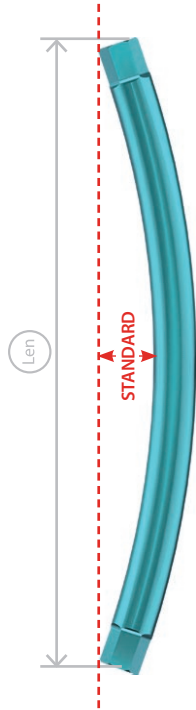

Len	Ti
35	3.6280.035
40	3.6280.040
45	3.6280.045
50	3.6280.050
55	3.6280.055
60	3.6280.060
65	3.6280.065
70	3.6280.070
75	3.6280.075
80	3.6280.080
85	3.6280.085
90	3.6280.090
95	3.6280.095
100	3.6280.100
110	3.6280.110
120	3.6280.120
130	3.6280.130
140	3.6280.140
150	3.6280.150
160	3.6280.160
170	3.6280.170
180	3.6280.180
190	3.6280.190
200	3.6280.200

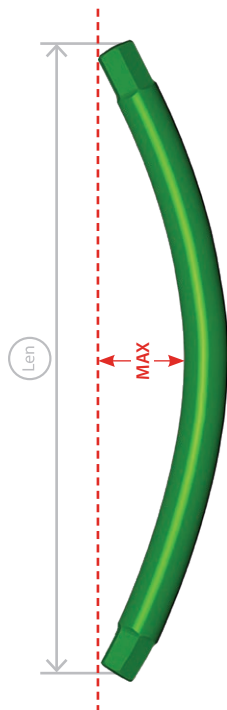

Len	Ti
35	3.6295.035
40	3.6295.040
45	3.6295.045
50	3.6295.050
55	3.6295.055
60	3.6295.060
65	3.6295.065
70	3.6295.070
75	3.6295.075
80	3.6295.080
85	3.6295.085

ANGLED ROD 6

CHARSPINE system 2

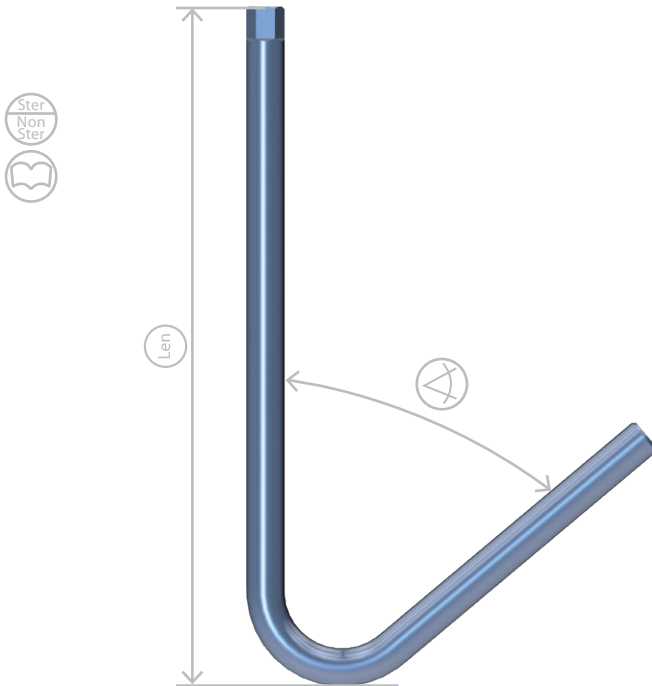

	Len	Ti
50°	150	3.3981.155
	200	3.3981.205
	250	3.3981.255
	300	3.3981.305
	350	3.3981.355
60°	450	3.3981.455
	150	3.3981.156
	200	3.3981.206
	250	3.3981.256
	300	3.3981.306
70°	350	3.3981.356
	450	3.3981.456
	150	3.3981.157
	200	3.3981.207
	250	3.3981.257
70°	300	3.3981.307
	350	3.3981.357
	450	3.3981.457

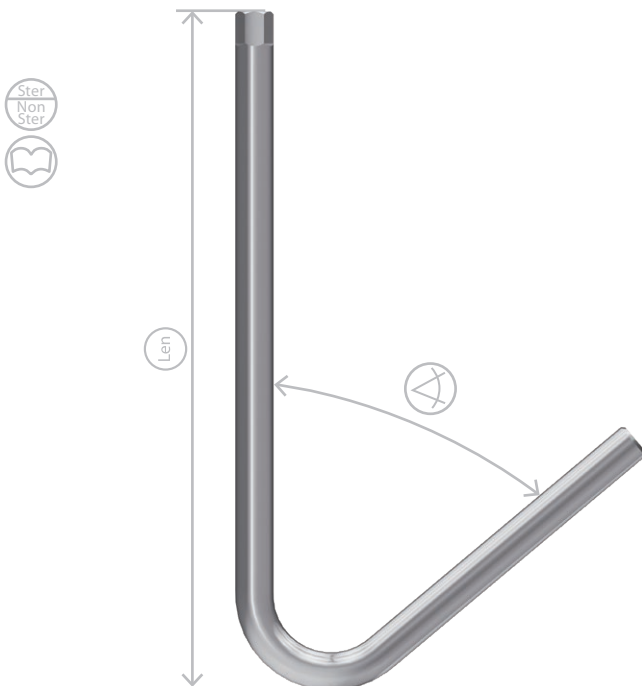



	Len	Co
50°	150	4.3981.155
	200	4.3981.205
	250	4.3981.255
	300	4.3981.305
	350	4.3981.355
60°	450	4.3981.455
	150	4.3981.156
	200	4.3981.206
	250	4.3981.256
	300	4.3981.306
70°	350	4.3981.356
	450	4.3981.456
	150	4.3981.157
	200	4.3981.207
	250	4.3981.257
70°	300	4.3981.307
	350	4.3981.357
	450	4.3981.457

ANGULAR CONNECTOR

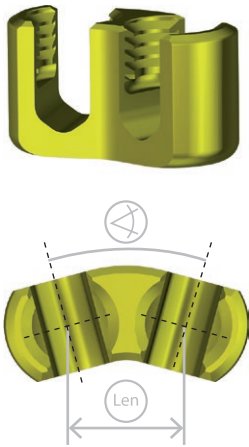
CHARSPINE system 2



	 Len	
0°	12	3.6284.012
	16	3.6284.016
10°	12	3.6285.012
	16	3.6285.016
30°	12	3.6286.012
	16	3.6286.016

CHARSPINE2 LOCKING SCREW





3.6160.000 ✓

LATERAL CONNECTOR

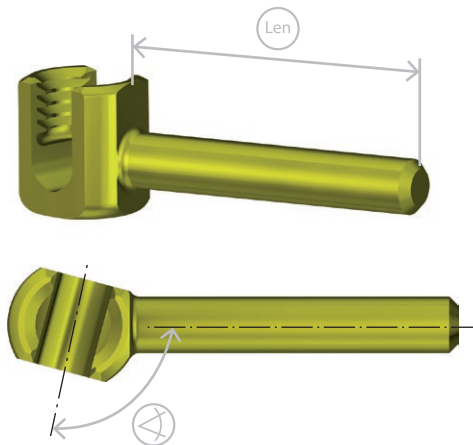
CHARSPINE system 2



	 Len	
90°	15	3.6281.015
	20	3.6281.020
	25	3.6281.025
	30	3.6281.030
	35	3.6281.035
75°	15	3.6282.015
	20	3.6282.020
	25	3.6282.025
	30	3.6282.030
	35	3.6282.035
105°	15	3.6283.015
	20	3.6283.020
	25	3.6283.025
	30	3.6283.030
	35	3.6283.035

CHARSPINE2 LOCKING SCREW



3.6160.000 ✓



The palettes for implants presented below are not offered as sets (they do not include implants).

40.8064.000
PALETTE FOR CHARSPINE2 IMPLANTS - SCREWS

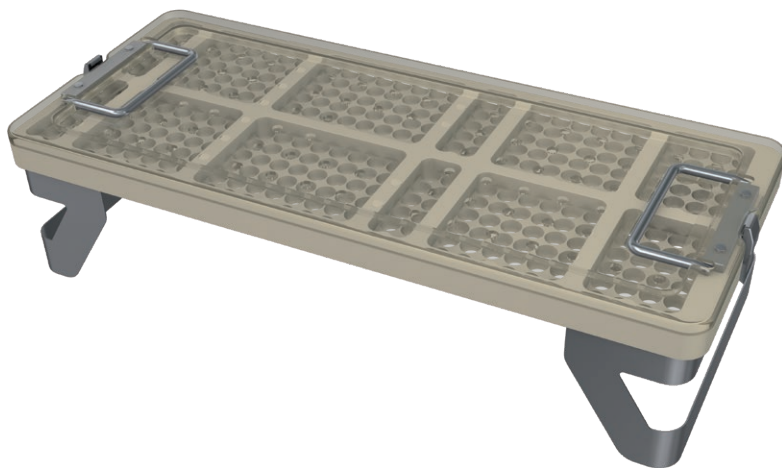

Screw diameter	Size L	No. of sockets
4.5	25	2
	30	2
	35	2
	40	2
	45	2
	50	2
5.0	35	2
	40	2
	45	2
	50	2
	55	2
	60	2
5.5	30	8
	35	8
	40	8
	45	8
	50	8
	55	8
6.0	35	8
	40	8
	45	8
	50	8
	55	8
	60	8
6.5	35	6
	40	6
	45	6
	50	6
	55	6
	60	6
7.5	35	6
	40	6
	45	6
	50	6
	55	6
	60	6
8.5	50	2
	55	2
	60	2
	70	2
	80	2
	90	2
9.5	50	2
	55	2
	60	2
	70	2
	80	2
	90	2
Monoaxial screws	30	4
	35	4
	40	4
	45	4
	50	4
	55	4
6.0	35	4
	40	4
	45	4
	50	4
	55	4
	60	4
6.5	35	6
	40	6
	45	6
	50	6
	55	6
	60	6
7.5	35	6
	40	6
	45	6
	50	6
	55	6
	60	6
Polyaxial screws	35	4
	40	4
	45	4
	50	4
	55	4
	60	4
6.0	35	4
	40	4
	45	4
	50	4
	55	4
	60	4
6.5	35	6
	40	6
	45	6
	50	6
	55	6
	60	6
7.5	35	6
	40	6
	45	6
	50	6
	55	6
	60	6

Monoaxial screws

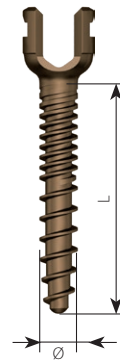

Polyaxial screws

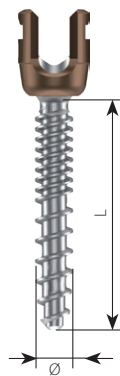

40.8119.000
 PALETTE SMALL FOR CHARSPINE2 IMPLANTS - SCREWS



Monoaxial, poly-
 axial and unipla-
 nar screws

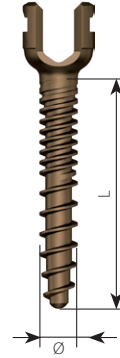

Screw diameter	Size L	No. of sockets
5.0	30	6
	35	6
	40	6
	45	6
	50	5
5.5	30	6
	35	6
	40	6
	45	6
	50	5
6.0	35	6
	40	6
	45	6
	50	6
	55	6
6.5	60	5
	35	6
	40	6
	45	6
	50	6
	55	6
	60	5

40.8065.000
 Palette for CHARSPINE2 implants - Connectors 1

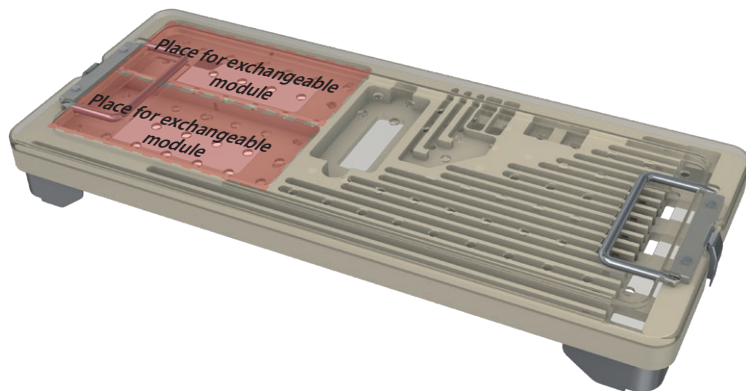

Implant type

Size

No. of sockets

Rods

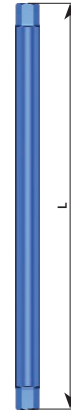

L-40 2

L-50 2

L-60 2

L-70 2

L-80 2

L-90 2

L-100 2

L-120 4

L-140 2

L-160 2

L-180 2

L-200 2

L-220 4

L-260 4

L-300 2

L-360 2

L-460 2

40.8066.000
 Palette for CHARSPINE2 implants - Connectors 2

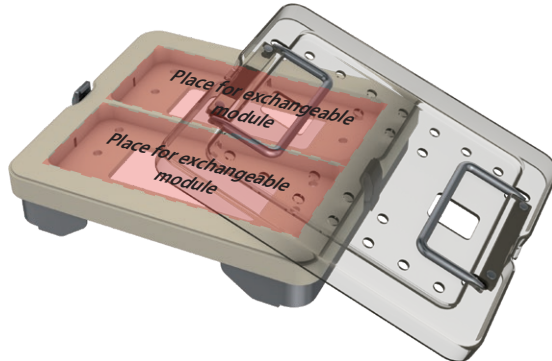

EXCHANGEABLE MODULES – IMPLANT SOCKETS CONFIGURATION

40.8078.000
Exchangeable module 1

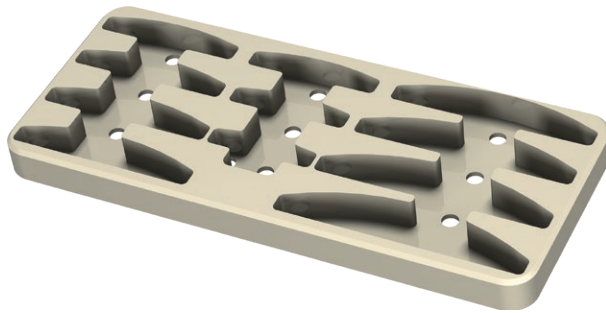

Implant type

Size

No. of sockets

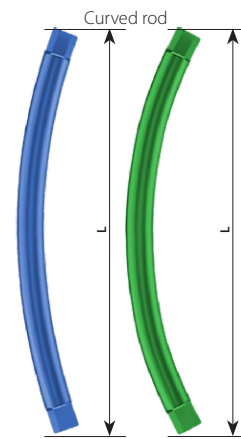

L-35 1

L-40 1

L-45 1

L-50 1

L-55 1

L-60 1

L-65 1

L-70 1

L-75 1

L-80 1

L-85 1

Rods

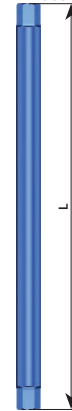

L-40 1

L-50 1

L-60 1

L-70 1

L-80 1

EXCHANGEABLE MODULES – IMPLANT SOCKETS CONFIGURATION

40.8081.000
Exchangeable module 4

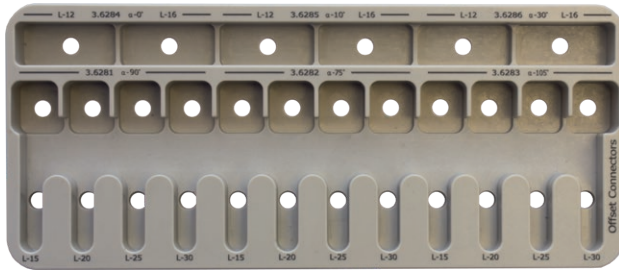

Implant type	Size	No. of sockets
Angular connector	L-12	1
	L-16	1
	10° L-12	1
	10° L-16	1
	30° L-12	1
	30° L-16	1
Lateral connector	90° L-15	1
	90° L-20	1
	90° L-25	1
	90° L-30	1
	75° L-15	1
	75° L-20	1
	75° L-25	1
	75° L-30	1
	105° L-15	1
	105° L-20	1
	105° L-25	1
	105° L-30	1

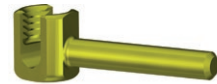
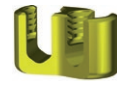

EXCHANGEABLE MODULES – IMPLANT SOCKETS CONFIGURATION

40.6795.000
Exchangeable module 5

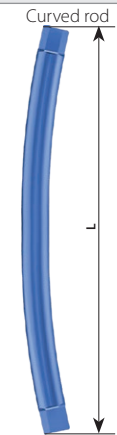
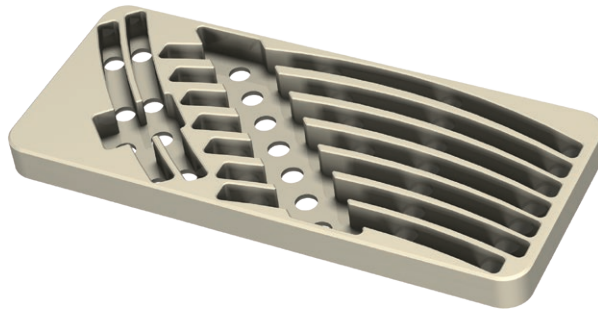

Implant type	Size	No. of sockets
Curved rod	L-90	1
	L-95	1
	L-100	1
	L-110	1
	L-120	1
	L-130	1
	L-140	1
	L-150	1
	L-160	1











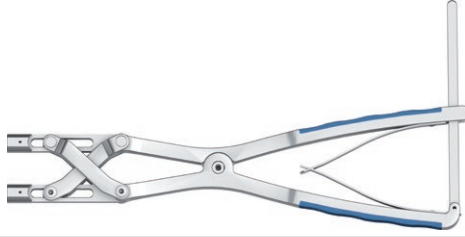

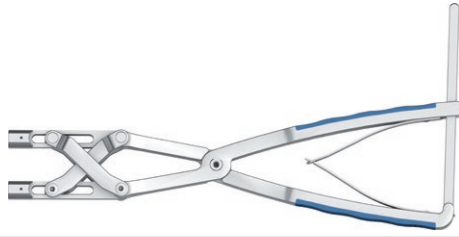

It is possible to change the configuration of modules included into palettes according to an individual order.

3. INSTRUMENTS

Instrument set for CHARSPINE2 spine stabilizer - basic [40.8800.000]			
	Name	Catalogue no.	Pcs
	Stand for CHARSPINE2 instrument set module 1	40.8802.100	1
	Screwdriver tip for polyaxial screws Screwdriver tip for polyaxial screws [40.6146] is a spare instrument for use with wrench for polyaxial screws [40.8090]. This makes it possible to insert two polyaxial screws by two operators simultaneously.	40.6146.000	1
	Screw persuader Screw persuader is used to press the rod down to the bottom of the transpedicular screw cut-out.	40.8096.100	1
	Holding forceps Holding forceps are used to conduct the rod derotation procedure.	40.6202.000	1
	Wrench for monoaxial screws Wrench for monoaxial screws is used for insertion and mounting of CHARSPINE2 monoaxial transpedicular screws. It is intended for use with T-type or oval head ratchet handle.	40.8089.100	1
	Wrench for polyaxial screws Wrench for polyaxial screws is used for insertion and mounting of CHARSPINE2 polyaxial transpedicular screws. It is intended for use with T-type or oval head ratchet handle.	40.8090.100	1
	Adjustable rod bender Adjustable rod bender is used to bend the rod to desired shape	40.8074.000	1
	Oval head ratchet handle Oval head ratchet handle is used with wrenches for screws and cortical taps (interchangeably with T-type ratchet handle 40.8085.000).	40.8086.000	1
	Thoracic pedicular trocar Thoracic pedicular trocar is used to prepare openings in the pedicle of the vertebral arch in the thoracic section of the spine.	40.8070.000	1
	Universal pedicular trocar Universal pedicular trocar is used to prepare openings in the pedicle of the vertebral arch in the lumbar section of the spine.	40.8071.000	1
	Straight pedicular trocar Straight pedicular trocar is used to prepare openings in the pedicle of the vertebral arch in the lumbar section of the spine.	40.8072.000	1
	Torque limiting ratchet handle T 12Nm Torque limiting ratchet handle T 12Nm is intended to be used with screwdriver tip T30 [40.6679.000] and is used for final tightening of the locking screws in the transpedicular screws, hooks and lateral connectors.	40.6678.120	1
	Stand for CHARSPINE2 instrument set module 2	40.8802.200	1

Instrument set for CHARSPINE2 spine stabilizer - basic [40.8800.000]

	Name	Catalogue no.	Pcs
	Parallel distraction forceps Distraction forceps are used with exchangeable jaws and are intended for procedure of vertebrae distraction.	40.8093.000	1
	Distraction forceps-jaws Exchangeable distraction jaws are used with distraction forceps.	40.5769.000	1
	Parallel compression forceps Compression forceps are used with exchangeable jaws and are intended for procedure of vertebrae compression.	40.8094.000	1
	Compression forceps-jaws W-26 (set) Exchangeable compression jaws are used with compression forceps.	40.5768.026	1
	Compression forceps-jaws W-46 (set) Exchangeable compression jaws are used with compression forceps.	40.5768.046	1
	Pliers for rod Pliers for rod are used to grab and insert the spinal rod.	40.8109.000	1
	Screwdriver T30 Screwdriver T30 is used for application and initial locking of the locking screws.	40.8111.000	1
	Screwdriver tip T30 Screwdriver tip T30 is intended to be used with T-type torque handle 12Nm [40.6678.120]. It is used to finally lock the transpedicular screws, hooks and lateral connectors.	40.6679.000	1
	Pedicule probe straight Pedicule probe is used to verify the continuity of the vertebral arch pedicle.	40.6698.000	1
	Pedicule probe curved Pedicule probe is used to verify the continuity of the vertebral arch pedicle.	40.6699.000	1
	Trocar Trocar is used to puncture the cortical layer of the vertebral arch pedicle, as a point of insertion of transpedicular screw.	40.8073.000	1
	Counter wrench Counter wrench is used to ensure rotational stability of the implants system during final tightening of the locking screws.	40.8095.000	1

















Instrument set for CHARSPINE2 spine stabilizer - basic [40.8800.000]

Name	Catalogue no.	Pcs	
 A gray, rectangular, perforated aluminum lid with a central rectangular cutout and small tabs on the sides.	Perforated aluminum lid 1/1 595x275x15mm Gray	12.0750.200	1
 A gray, rectangular, solid-bottom container with a slightly raised rim and a latch on the right side.	Container with solid bottom 1/1 595x275x135mm	12.0750.102	1

Additional instruments, not included in the set, for bone cement delivery through an open access

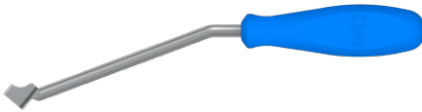

In order to include the below-listed instruments to the ordered **CHARSPINE2** instruments, please contact your local representative or ChM Sales Department.

	Name	Catalogue no.	Pcs
	Trocar Trocar is used to penetrate the cortex of the pedicle and to insert the guide rod.	40.8601.000	1
	Guide rod 1.5/500 Blunt rod. It is the guiding element for other instruments, e.g. used for screws insertion.	40.8559.000	1
	Cortical tap 4.5	40.8567.045	1
	Cortical tap 5.0	40.8567.050	1
	Cortical tap 5.5	40.8567.055	1
	Cortical tap 6.0	40.8567.060	1
	Cortical tap 6.5	40.8567.065	1
	Cortical tap 7.0	40.8567.070	1
	Cortical tap 7.5	40.8567.075	1
	Cortical tap 8.5	40.8567.085	1
	Cortical tap 9.5	40.8567.095	1
	Cortical tap 10.5	40.8567.105	1
	Wrench for polyaxial screws The wrench is used for polyaxial fenestrated screws insertion through an open access. Should be used with oval head ratchet handle [40.8086.000].	40.6735.100	1
	Cannula for bone cement Single use cannula for bone cement is intended to be used with CHARSPINE2 MIS screws. The universal Luer thread allows the cannula to be connected with a mixing and delivery system for bone cement.	40.8591.000	1
	Alignment trial for cannula Alignment trial for cannula, inserted through the cannula for bone cement attached to the CHARSPINE2 MIS screw, is intended to confirm the coaxiality of the holes in the cannula and screw.	40.8592.000	1
	Pusher Pusher is used to remove residual bone cement from the cannula.	40.8596.000	1
	Wrench Wrench facilitates the removal of the guide sleeve	40.8580.000	1
	Counter wrench Counter wrench is used to immobilize the head of the polyaxial screw when installing/ removing the cannula for bone cement.	40.6749.000	1

3.1. CONTAINERS ARRANGEMENT

Containers for basic instrument set
[40.8800.000]

No.	Name	Catalogue No.	Pcs
1	Perforated aluminum lid 1/1 595x275x15mm Gray	12.0750.200	1
2	Stand for CHARSPINE2 instrument set module 1	40.8802.100	1
3	Stand for CHARSPINE2 instrument set module 1	40.8802.200	1
4	Container with solid bottom 1/1 595x275x135mm	12.0750.102	1



4. SURGICAL TECHNIQUE

Anterior approach to thoracolumbar spine

Surgical procedures on the thoracolumbar spine by means of anterior approach are generally performed with a patient in a lateral position, with the assistance of a general or vascular surgeon.

4.1. THORACOTOMY

Thoracotomy is a standard approach for the treatment of thoracic spine disorders such as deformity, tumor or infection. In case of deformity treatment, the approach is always located on the side of the curve apex, e.g. a right-sided thoracotomy is chosen for a right-sided curve. In general, a left-sided thoracotomy is preferred, especially in the lower thoracic area, due to right-sided location of the liver which limits the operative field. However, when the upper part of the thoracic spine is concerned, some surgeons favour right-sided approach (*in cases when the spinal pathology does not dictate the side of thoracotomy*) to avoid subclavian and carotid arteries in the left superior mediastinum.

Indications

Spinal pathologies (*deformities, degenerations, fractures, tumours, infections*) that are located between T4 and T10 are indications for the thoracotomy.

Patient positioning

In case of right-sided thoracotomy, the patient is lying on the left side on a soft, rubber mattress. The arms are positioned at elevation of 90° and with the elbows flexed. The legs are kept straight, with the right leg resting on the left leg. The symphysis and the sacrum are supported by pads to maintain the specified position. Prior to skin incision, the side of thoracotomy and the level involved are to be confirmed. It is essential to center the incision right over the pathology place and to select the intercostal space correctly. To confirm the selected spine level, it is recommended to count the ribs and to compare the result with the radiograph.

The skin incision shall be extended from the lateral border of the paraspinous muscle up to the sternocostal joint.

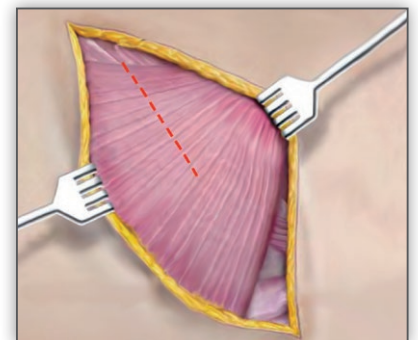
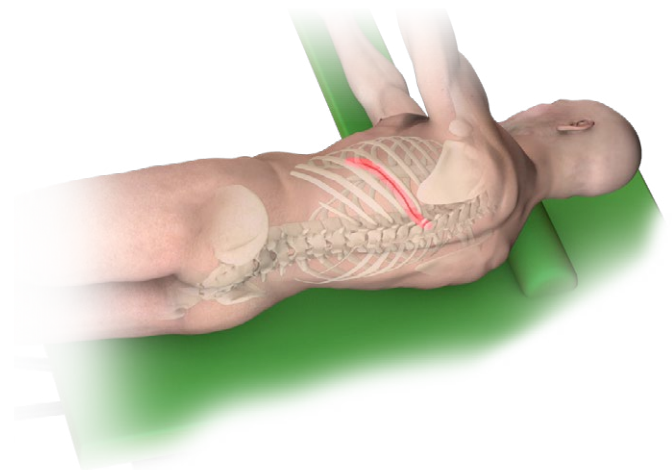

4.2. ANTERIOR THORACOLUMBAR APPROACH

The anterior approach to thoracolumbar section may be used if there is a need of simultaneous exposure of vertebral bodies of lower thoracic and upper lumbar parts of the spine. Technically, this approach is more difficult than thoracotomy because of the diaphragm exposed and the increased risk of simultaneous exposure of the thoracic cavity and the peritoneal space. If the spine pathology does not determine the side of the approach, the access from the left side is preferred due to right-sided location of the liver.

Indications

The anterior thoracolumbar approach is recommended for spine pathologies mentioned as an indication for thoracotomy and situated between T9 and L5.

Patient positioning

The patient is placed in the right lateral decubitus position, with supports placed beneath the thorax and shoulders. The table may be slightly bent above the level of pelvis to increase the distance between pelvis and thorax.

During the operation special care should be taken to not harm the branches of the phrenic nerve, which are extending peripherally from the center towards anterolateral and posterior direction. It is recommended to make the incision around the periphery of the diaphragm to minimize the interference with its function when making the thoracoabdominal approach to the spine.

Special care should also be taken when entering the abdominal cavity.

To gain the best access to the space between T12 and L1, it is usually recommended to resect the tenth rib which allows exposure between T10 and L2.

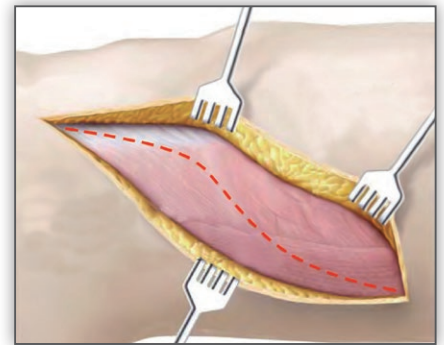
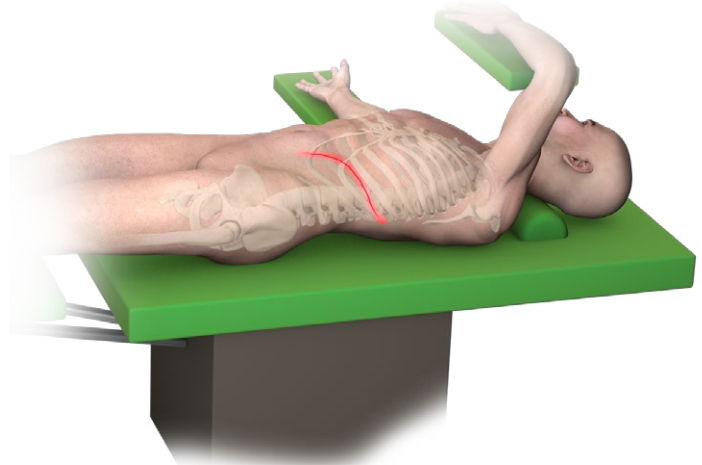

4.3. ANTERIOR RETROPERITONEAL APPROACH

The anterior retroperitoneal approach to the lumbar vertebral bodies is a modification of the anterolateral approach commonly used by general surgeons during the sympathectomy. It allows for superior, multilevel access to the lumbar spine.

Indications

The anterior retroperitoneal approach is recommended for spine pathologies (*deformities, degenerations, fractures, tumours, infections*) situated between L2 and L5.

Patient positioning

The patient is placed in the decubitus position, in most cases on the right side. Most often, the approach is made from the left side to prevent damage to the liver and the inferior vena cava. To better expose the space between the twelfth rib and the iliac crest, the table planes may be flexed. Lower limbs are bent slightly in hips to release the tension of the psoas muscle.

The incision is to be oblique, above the twelfth rib, from the lateral border of the quadratus lumborum muscle to the lateral border of the rectus abdominis muscle, in order to allow access to the first and second lumbar vertebrae.

When the lower vertebrae (*from L3 to L5*) are exposed, the incision is to be made a few fingers below and parallel to the costal margin.

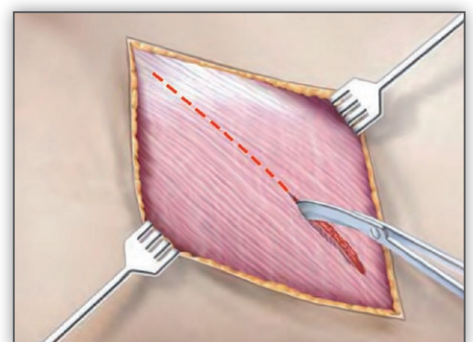
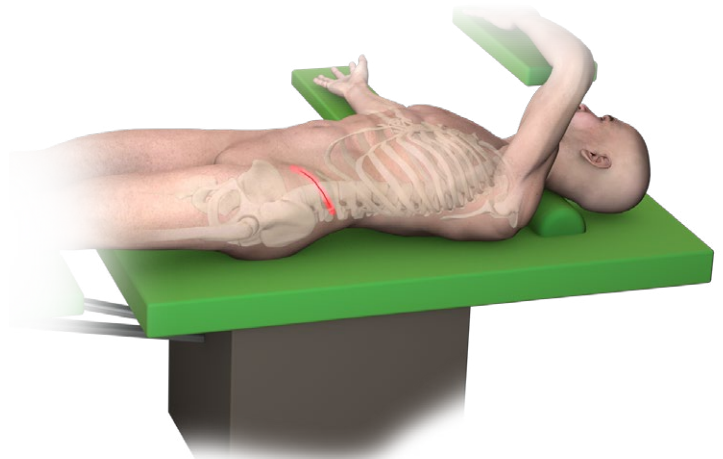

4.4. POSTERIOR APPROACH TO THE THORACOLUMBAR APPROACH

The posterior approach to the thoracolumbar spine can be made through standard midline longitudinal incision with lateral retraction of the erector spinae in the direction of the transverse processes tips. This approach allows for access to the spinous processes, vertebral arches and joints at all levels.

The target spine level should be determined using the X-Ray control, so that the spine is unveiled only at the required segment.

Indications

The anterior approach to the thoracolumbar spine is recommended for spine pathologies (*deformities, spine canal stenoses, fractures, degenerations, tumours, infections, instabilities, herniations*) situated between T1 and L5.

Patient positioning

Patient is placed prone on rubber-foam supports. To avoid excessive pressure and pressure sores, a headrest with support for mouth, nose and eyes should be used. It is vital to avoid any pressure on the abdomen. It is crucial while decompressing the spine, as pressure on abdomen may cause vein congestion and thus excessive intraoperative bleeding.

Positioning the patient on a bending surgical table with supports with flexion of hip and knee joints allows for reduction of lumbar lordosis and easier access to posterior spine elements and spine canal structures, especially at the lumbosacral junction.

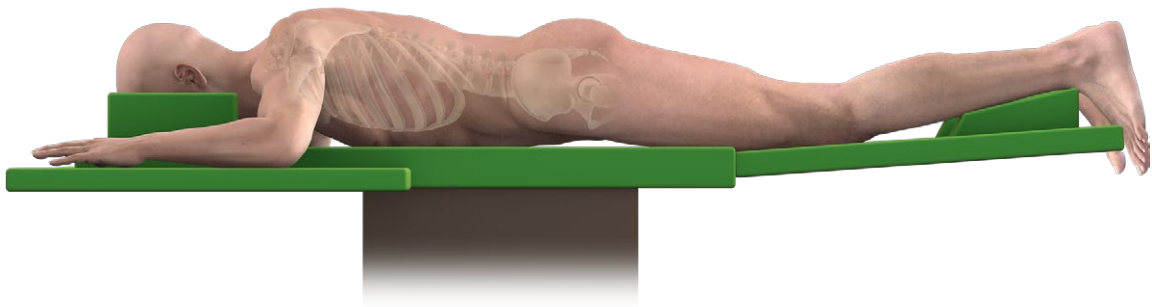
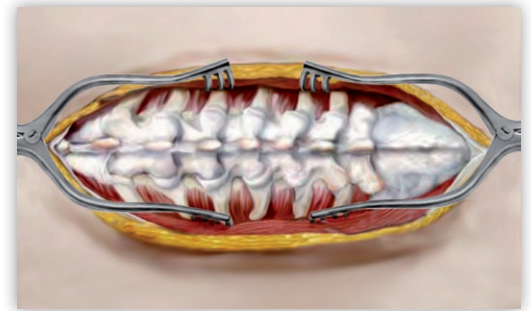
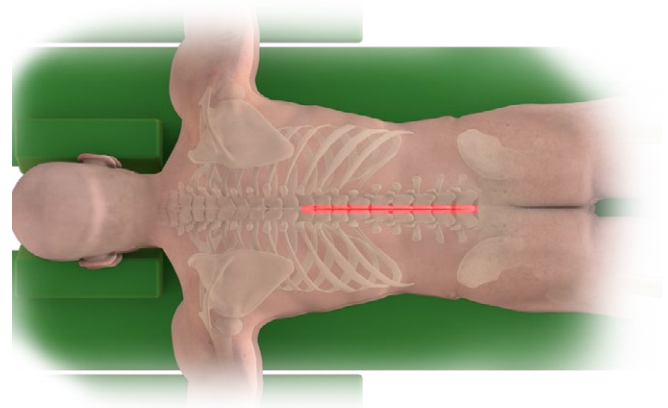

4.5. APPROACH TO POSTERIOR SUPERIOR ILIAC SPINE

Indications

This approach is recommended when the following occur: a significant lumbopelvic instability (*caused by damage at S1 level resulting from trauma, tumour or infection*) or long thoracolumbosacral instrumentation of scoliosis, causing a high risk of instability of the lumbosacral connection.

Patient positioning

Patient is positioned in the same manner as presented in section IV.4.

Screw implantation in pelvis requires access to the posterior superior iliac spine. First, the lumbosacral spine is exposed. The posterior superior iliac spine may be exposed with a separate, longitudinal skin incision, bilateral resection of the myofascial flaps and retraction in lateral and cephalad direction.

The entry point is located at the lower part of the posterior superior iliac spine. It is recommended to use osteotome (*or rongeur*) to remove a fragment of the iliac crest around the screw head or to sink the screw head in the bone to avoid any screw prominence, especially when slim patients are concerned.

4.6. SCREW SELECTION. PREPARATION OF THE SCREW ENTRY POINT

During transpedicular stabilization it is of vital importance to select appropriate screw diameter for specific vertebrae and to carefully choose the site and a angle of insertion. Depending on the location level, the pedicles of vertebrae arches are varied in terms of shapes and geometry (e.g. the cross section of the vertebrae arch pedicles in the thoracic spine indicates an irregular, kidney-like shape with the medially-directed convexity).

Taking into consideration the above-mentioned, the initial selection of screw diameter and length has to be performed within the preoperative procedures, individually for each vertebrae on the basis of CT and X-Ray images (in AP and lateral projections).

The internal dimension of the arch of a vertebrae pedicle (*W*) is of vital importance when choosing the external diameter of the transpedicular screw. It is crucial to remember that the pedicle dimensions obtained on the basis of imaging in AP projection are not real dimensions and should be treated as approximate values only. In general, the outer diameter of the screw is 2 mm smaller than the internal dimension of the vertebrae pedicle arch.

Screw insertion point is located at the intersection of a line that divides the transverse processes in half and the line along the lateral aspect of the superior articular process.



The surgeon shall decide about the size of screws on the basis of CT and X-Ray imaging and intraoperative identification (probing the pedicle).

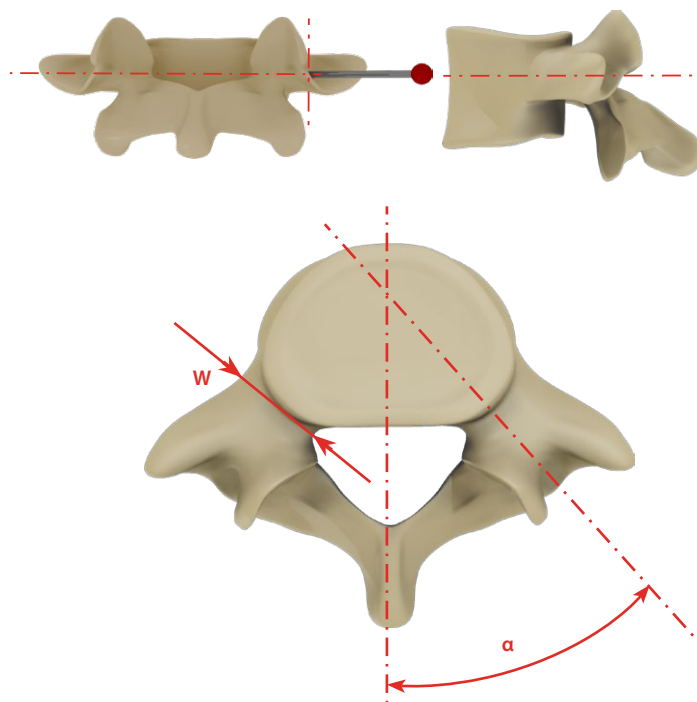

There are two alternative trajectories for insertion of screws through the thoracic vertebrae pedicles:

- A – anatomical approach
- B – straight approach (direct)

The insertion point is located at the intersection of a line in sagittal projection about 1 mm in medial direction from the lateral edge of the lamina and of a line along the transverse processes about 1 mm below the surface of the superior articular process.



If anatomical approach is used, only polyaxial screws are to be used.
If straight (direct) approach is used, both normal and polyaxial screws may be used.

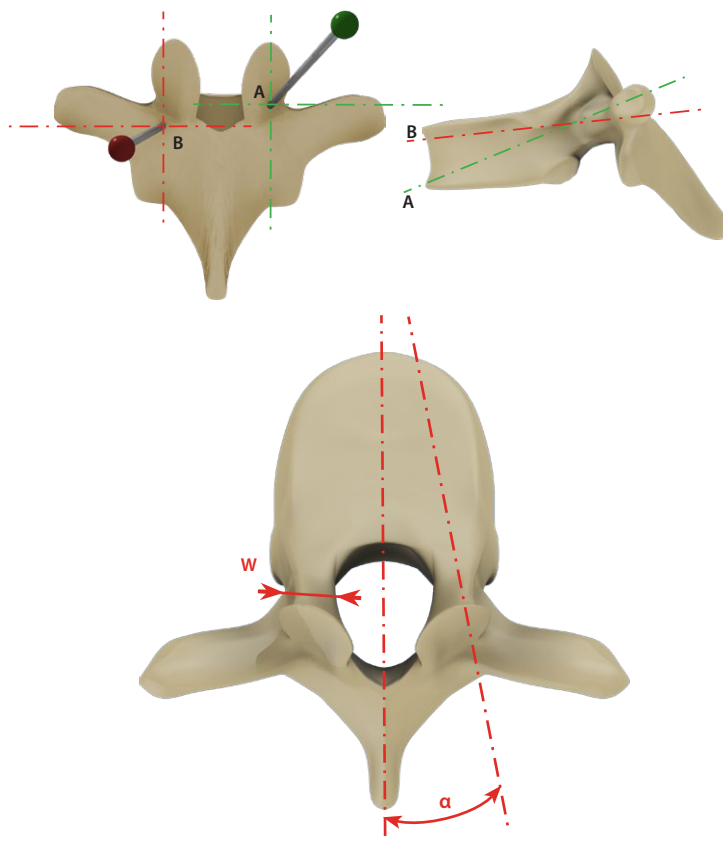

4.7. INSERTION OF SCREWS. POSTERIOR APPROACH

4.7.1. PREPARATION OF VERTEBRAL ARCH PEDICLES



40.8073.000

The point of screw insertion is prepared with a trocar [40.8073.000] which is used to puncture the cortical layer of the vertebral arch pedicle.

When it is necessary a bone rongeur is used to remove the upper part of the vertebral articular process at the screw insertion point, therefore the cancellous bone right under the cortical layer and the access to the vertebral arch pedicle are exposed.

Pedicle diameter and the angle should be determined prior to the operation by means of imaging studies. It allows for later determination of depth and angle of the prepared canal and the screw diameter.



40.8070.000



40.8071.000



40.8072.000

An opening for screw is prepared with the use of a pedicular trocar (which is available as: universal [40.8071.000], straight [40.8072.000] and thoracic [40.8070.000]).

The instrument is inserted by means of delicate rotary-oscillatory movement.

The tip should be inserted carefully, led along the interior walls of the vertebral cortical bone with the smallest resistance possible, so the vertebra walls remain undamaged.



Trocar tip has marked depth indicators in five-millimeter increments to help determine the correct length of the transpedicular screw.

Identical procedure should be used while preparing the opening in the second pedicle.

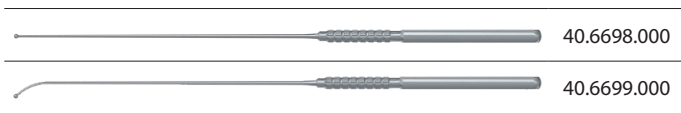





Prior to screw insertion, it is recommended to check the continuity of all walls of the vertebral arch pedicle with the help of the pedicle probe [40.6698] or [40.6699].

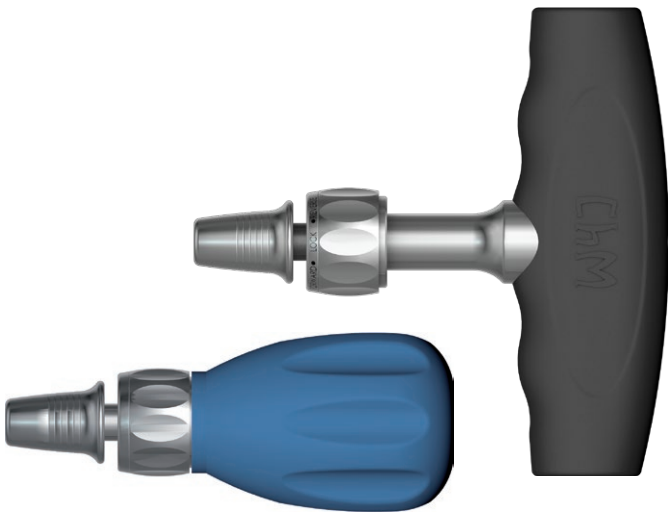

4.7.2. INSERTION OF SCREWS



	40.6678.120
	40.8086.000
	40.8089.100
	40.8090.100

Wrenches for monoaxial [40.8090.100] and polyaxial screws [40.8089.100] are intended to be mounted on:

- torque limiting ratchet handle T 12Nm [40.6678.120],
- oval head ratchet handle [40.8086.000].

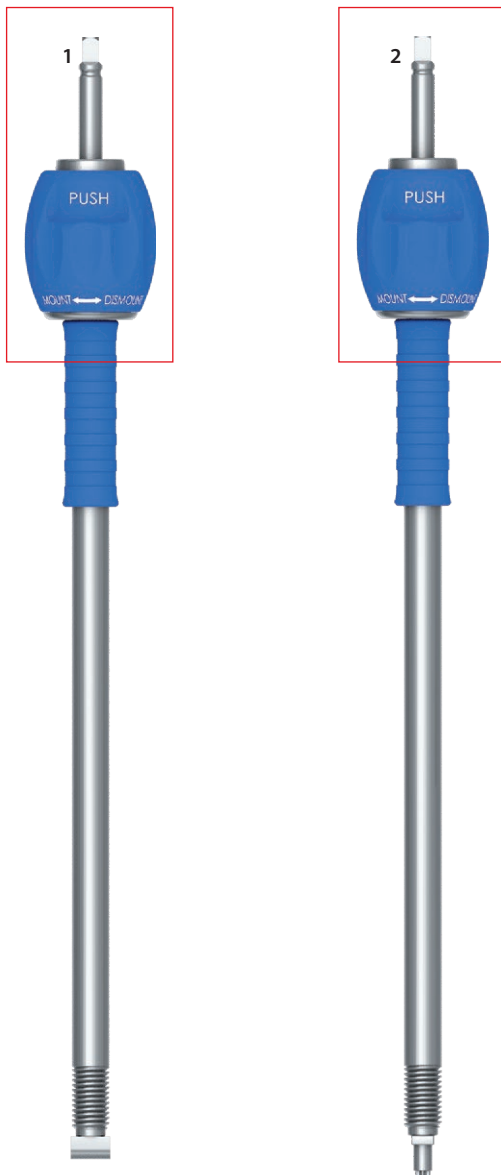

Wrench for monoaxial screws [40.8089.100]

Wrench for polyaxial screws [40.8090.100]

Monoaxial and polyaxial wrenches have a ratchet mechanism that prevents any spontaneous loosening of the tip-screw connection during the transpedicular screws insertion.



Tips 1 and 2 of wrenches for screws are exchangeable. In order to disconnect the tip from the wrench [40.8090] or [40.8089], press and hold the PUSH and then remove the tip from the wrench sleeve.

The instrument set is equipped with additional tips for polyaxial screws [40.6146]. Therefore, two wrenches for polyaxial screws may be used by two operators simultaneously.



A tip for monoaxial screws [40.6145] may be additionally ordered. The instrument has its place provided on the stand.

Square end of the wrench is mounted in the quick coupling end of the handle
[40.6678.120] or [40.8086.000].

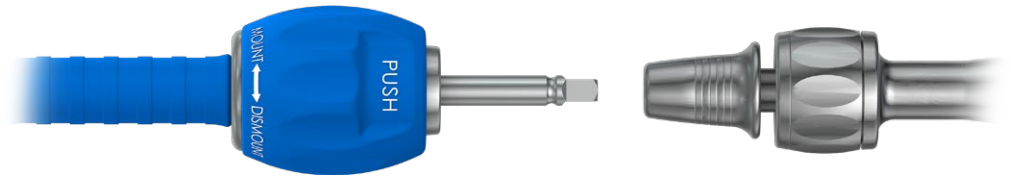

Then an appropriate length and diameter of the transpedicular screw (*mono- or polyaxial*) is selected.

The tip is inserted all the way into the screw head:

- in the case of monoaxial screws, a tip of wrench for monoaxial screws is to be used.



- in the case of polyaxial screws, a tip of wrench for polyaxial screws is to be used.

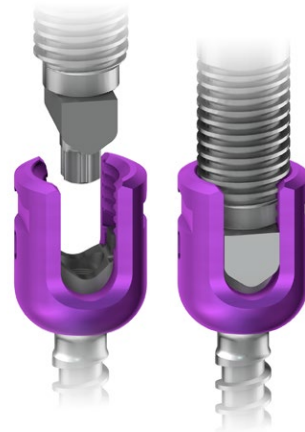

By turning the knob clockwise, tighten the threaded, external wrench sleeve all the way until the tip is completely seated at the bottom of the screw channel. Tightening direction is marked using arrow and MOUNT sign.

While tightening, with increasing resistance, the wrench knob automatically activates locking mechanism that will prevent the screw from being released from the wrench.

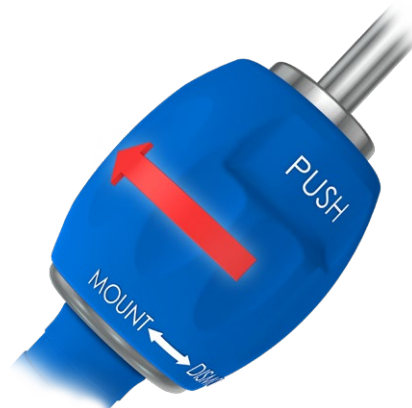



The screw mounted on a wrench is inserted into an opening prepared beforehand.



Screw insertion should be controlled in two planes with the help of X-Ray control.



Remember that precise positioning of the screws is realised by screwing in, and not by screwing out.



Moving back the screw may result in loss of connection stability and may necessitate the use of a larger diameter screw.



When screwing in, do not hold your hand on the oval handle of the wrench for screws, as this will cause the locking mechanism to disengage. If there is a need to use the other hand to hold the wrench, grasp the sleeve portion below the knob.

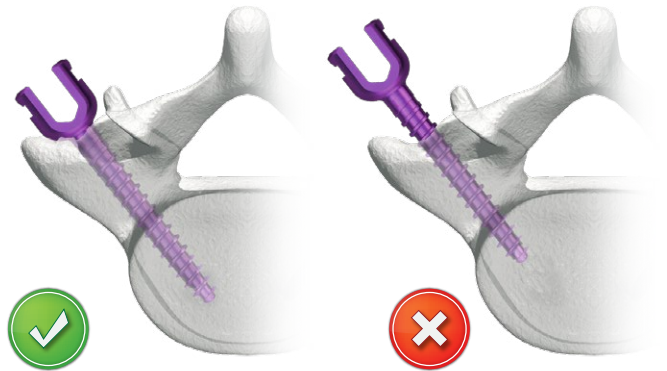

The core of the transpedicular screw is strengthened in the vicinity of its head. To reduce the potential risk of screw breakage, it is necessary to screw it all the way in so the whole thread is in the bone.



To remove the wrench from the screw, turn knob counter-clockwise as shown by the arrow and DISMOUNT sign.

The locking mechanism of the wrench will disengage automatically.

4.7.3. ROD SHAPING

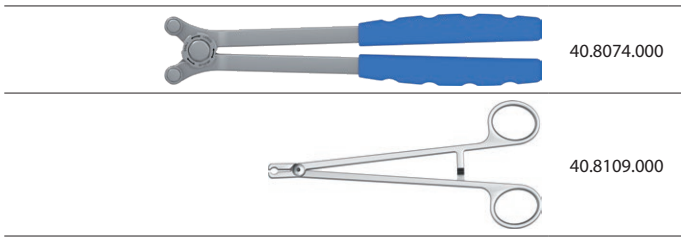

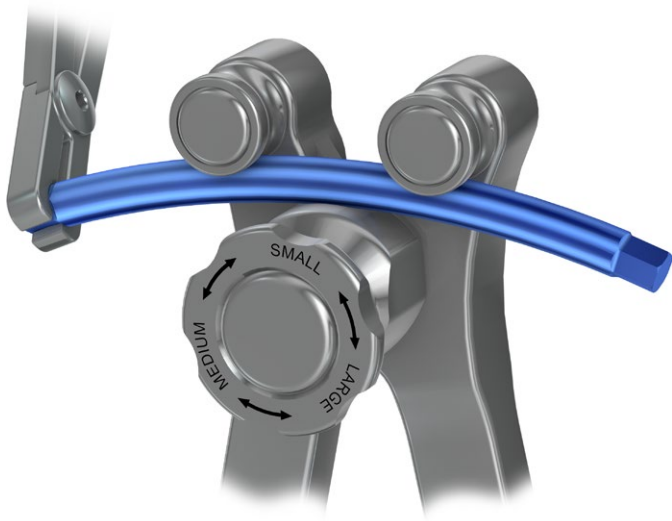

Having inserted the screws, select a rod of appropriate length.

To achieve the desired spine curvature (e.g. lordosis or kyphosis), the rod should be appropriately shaped. Shaping is performed with the help of adjustable rod bender [40.8074.000].



CHARSPINE2 system allows the usage of rods of two types of rigidity:

1.		Rod Ø6 made of titanium alloy in accordance with ISO 5832-3/ASTM F136	standard rigidity
2.		Rod Ø6 made of cobalt alloy in accordance with ISO 5832-12/ASTM 1537	very high rigidity

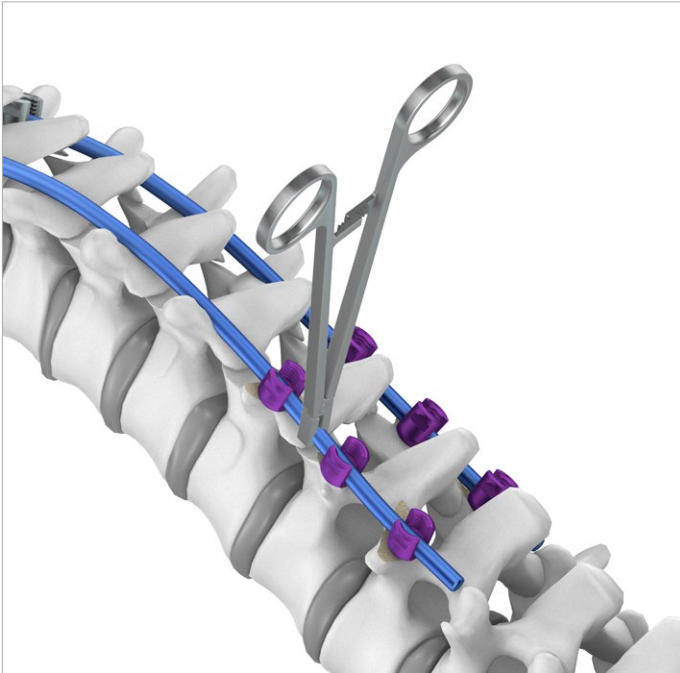

40.8109.000

Appropriately shaped rods are inserted into cut-outs of transpedicular screws with the help of pliers for rod [40.8109.000].



40.5288.000

If necessary, cut the rod to the desired length with the use of hand held rod cutter [40.5288].



Hand hold rod cutter is a non-standard instrument and is not included into the CHARSPINE2 instrument sets.

4.7.4. ROD FIXATION

The rod is locked by inserting the locking screw [3.6160.000] into the transperpendicular screw head.



The locking screw may be mounted on the screwdriver tip only from the upper side of the screw (the locking screw design eliminates any errors related to the mounting).



The upper surface of the screw is colour-marked to allow for easier identification.



40.8111.000

The locking screw is mounted on the tip of the screwdriver T30 [40.8111.000], then it is inserted into the cut-out on the screw head and screwed in slightly in a clockwise direction, simultaneously gently pressing the rod to the screw cut-out bottom.

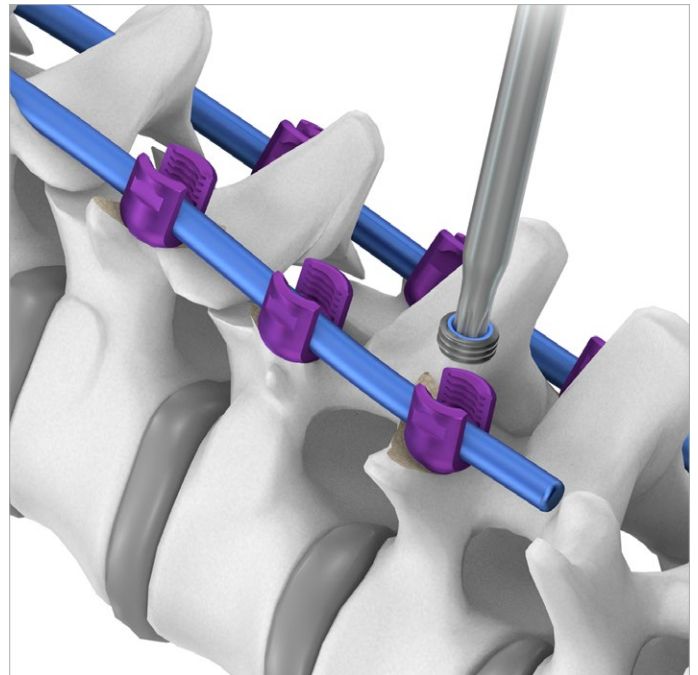

It is necessary to make sure that the rod and locking screw are completely mounted on the bottom of the screw head:

- the rod must completely adhere to the cut-out bottom in the screw head,
- the upper part of the locking screw (in blue) should flush with the upper part of the screw head.



It is necessary to avoid the following:

- the rod is not placed horizontally in the screw head,
- the rod is high and does not adhere to the bottom of the screw head cut-out,
- the screw is embedded in the place of rod bending (on the convexity or concavity of the arch).

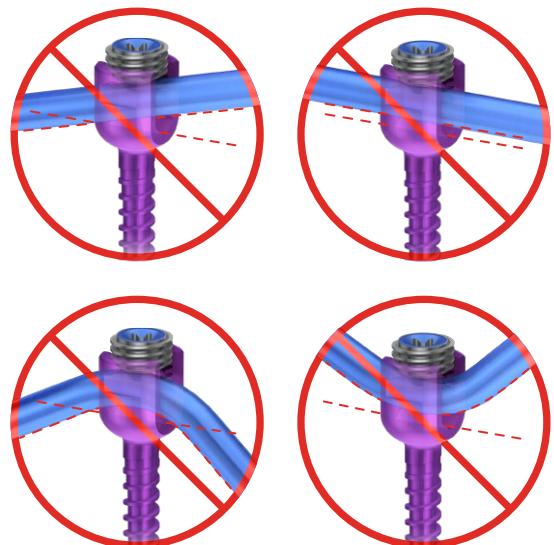

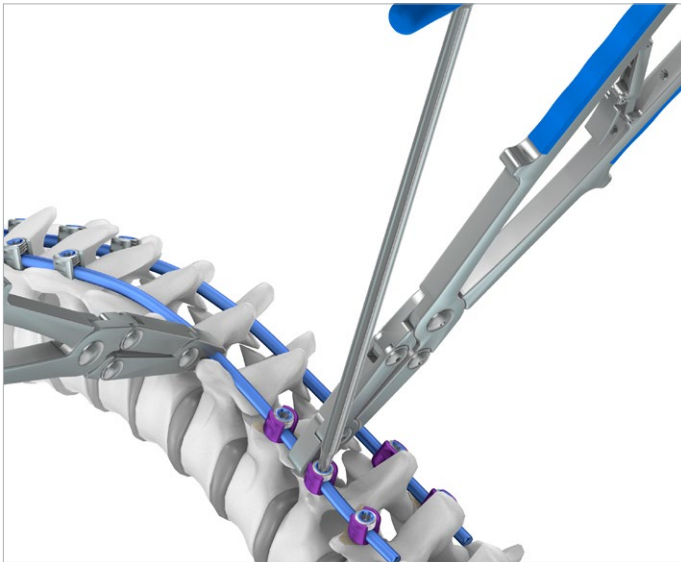

40.6202.000

It is possible to use the holding forceps [40.6202.000] during the procedure of rod derotation.

In such case, having established the desired rod position, the rod should be locked to maintain its position.

This allows for the next stage to be performed - the reposition of vertebrae.

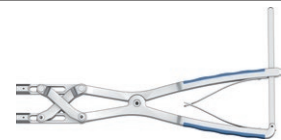

40.8093.000



40.5769.000



40.8094.000



40.5768.026



40.5768.046

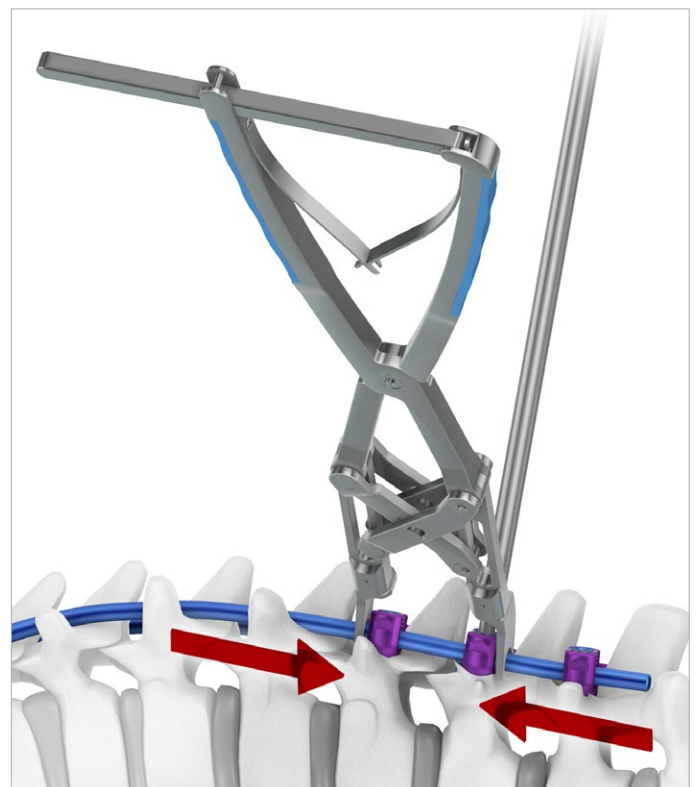
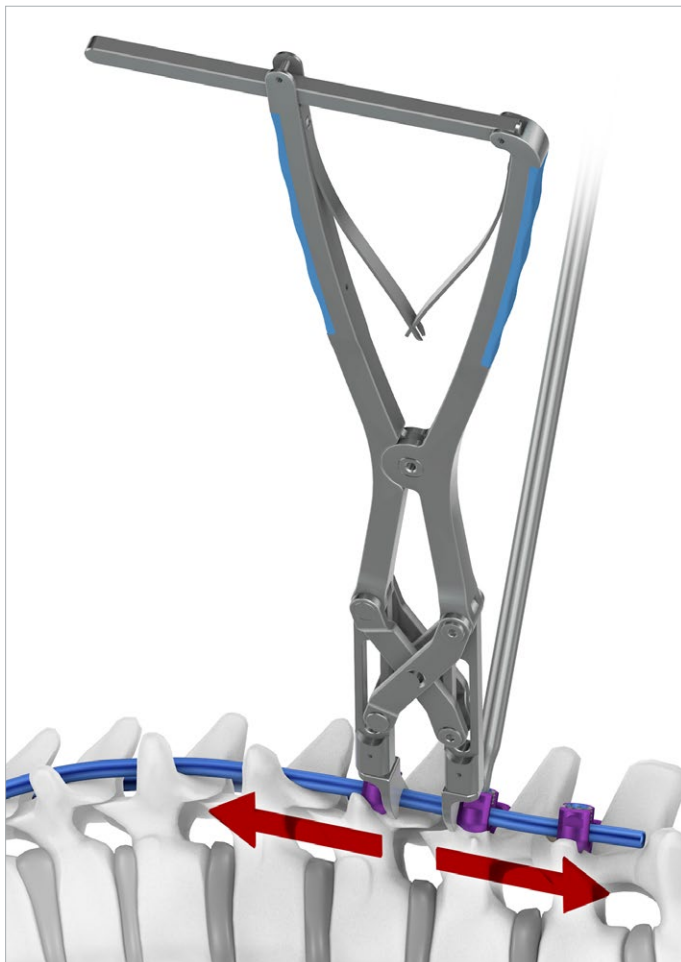

At this stage it is possible to perform:

- the vertebrae distraction with the use of parallel distraction forceps [40.8093.000],
- the vertebrae compression with the use of parallel compression forceps [40.8094.000].



A proper shaping of rods is a crucial stage of surgery allowing for good vertebrae reposition.

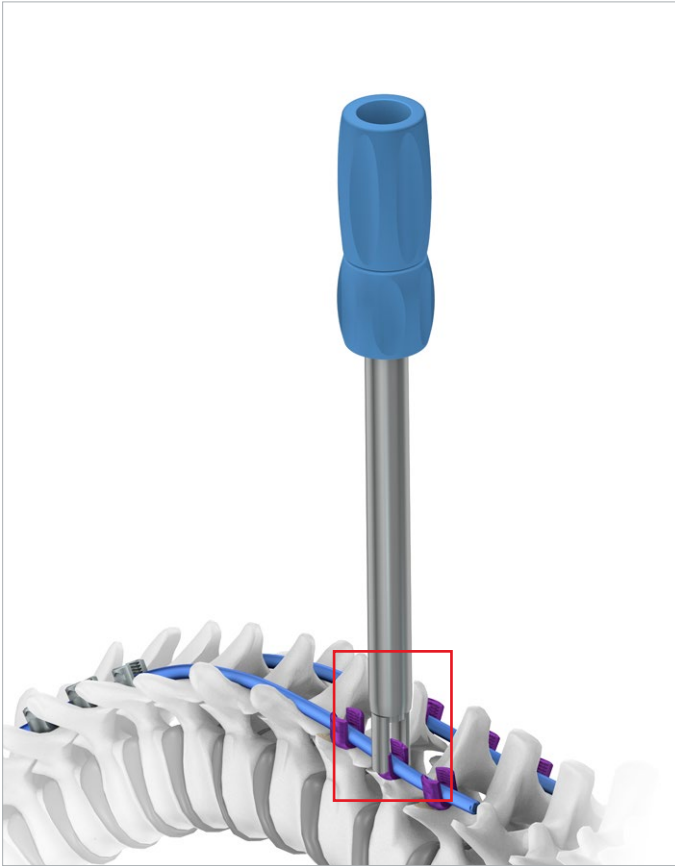

If more force is necessary to impact the rod into the bottom of the transpedicular screw cut-out, it is possible to use screw persuader [40.8096.100].



Prior to use, extend the clamping arms of the persuader as far as possible by turning the knob counterclockwise until a distinct resistance is felt.



Incompletely extended clamping arms of the persuader may cause the instrument to be improperly connected with the screw and may damage the device.

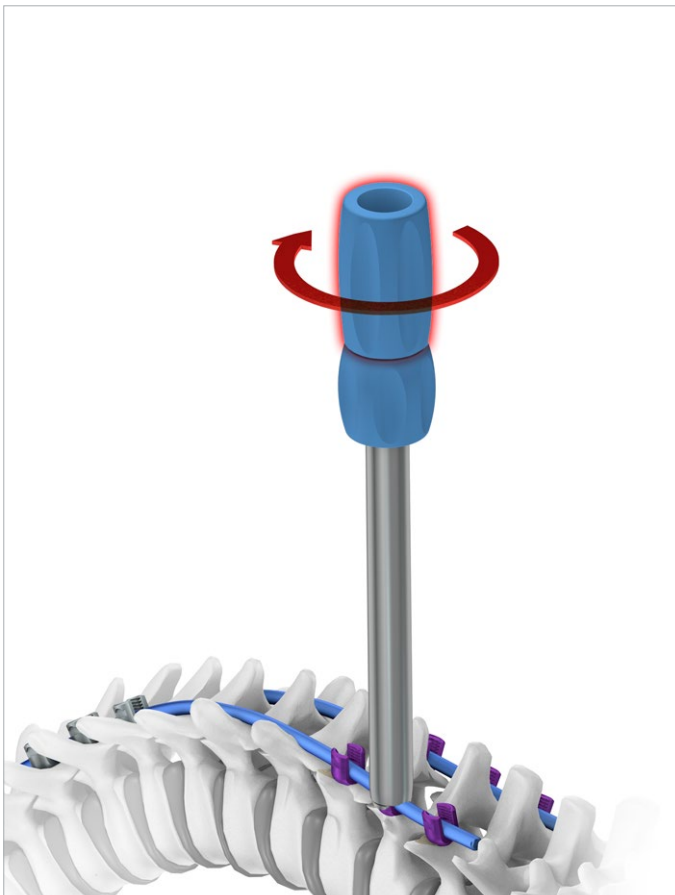

Then, by turning clockwise, the rod may be smoothly pushed down to the bottom of the screw.

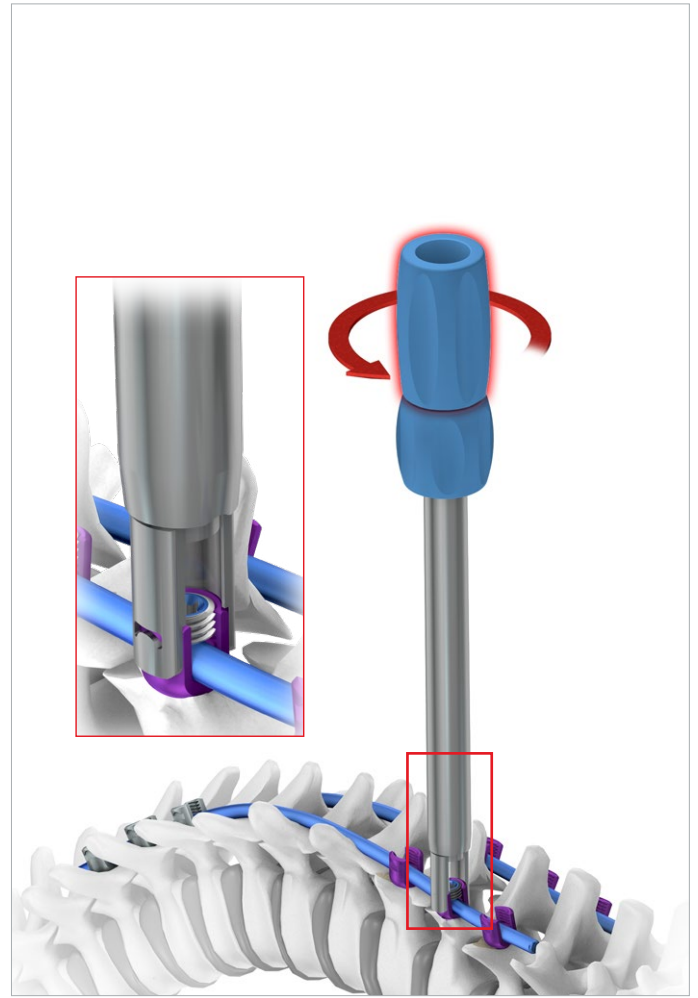

Then turn the persuader knob counterclockwise to loosen the device and extend the clamping arms completely.

To secure the rod, insert the locking screw through the cannulated opening of the screw persuader (the screw is mounted on the screwdriver tip T30 [40.8111.000]) and initially screw it in.

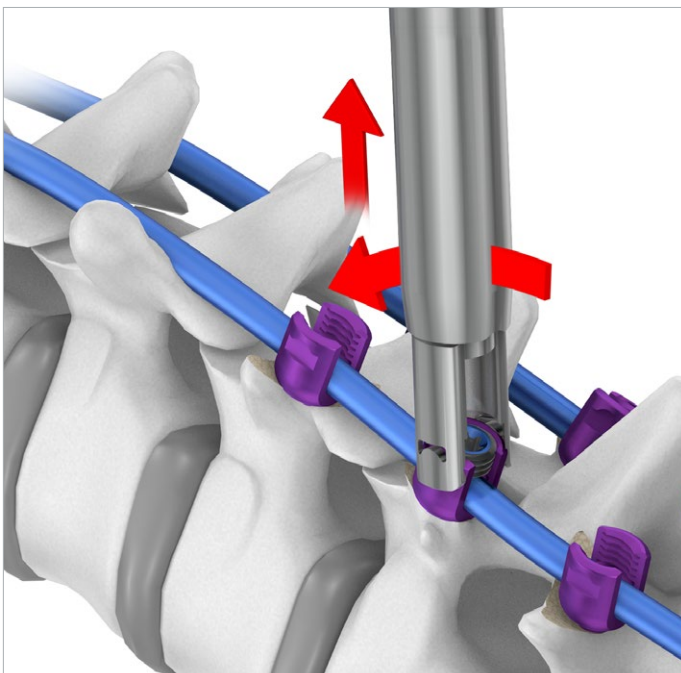

The device is dismantled from the transpedicular screw by skewing the device in the rostral-caudal direction.



Incompletely extended clamping arms of the persuader may damage the device while dismantling.

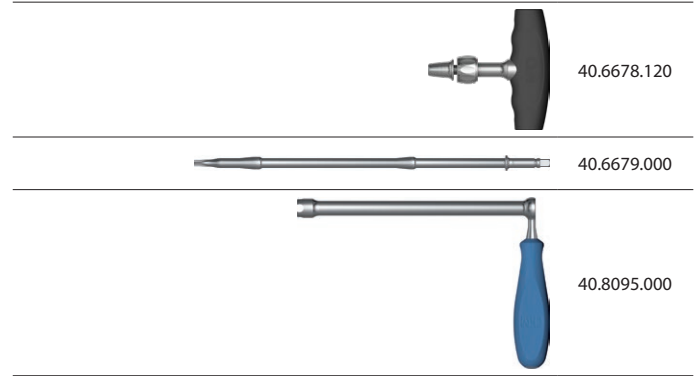

Having established the required vertebrae position, finally screw in the locking screws with the help of T-type torque handle 12Nm [40.6678.120] connected with screwdriver tip T30 [40.6679.000].

When the required torque of 12Nm is reached, the dynamometric mechanism signals it with an audible snap.

To eliminate the movement of rod-screws system while screwing in the locking elements use the counter wrench [40.8095.000].



To maintain high level of safety and correctness of operation of the torque wrench, it is necessary to keep the calibration date presented on the stopper of the instrument handle. The instrument calibration is performed by the manufacturer - ChM sp. z o.o.

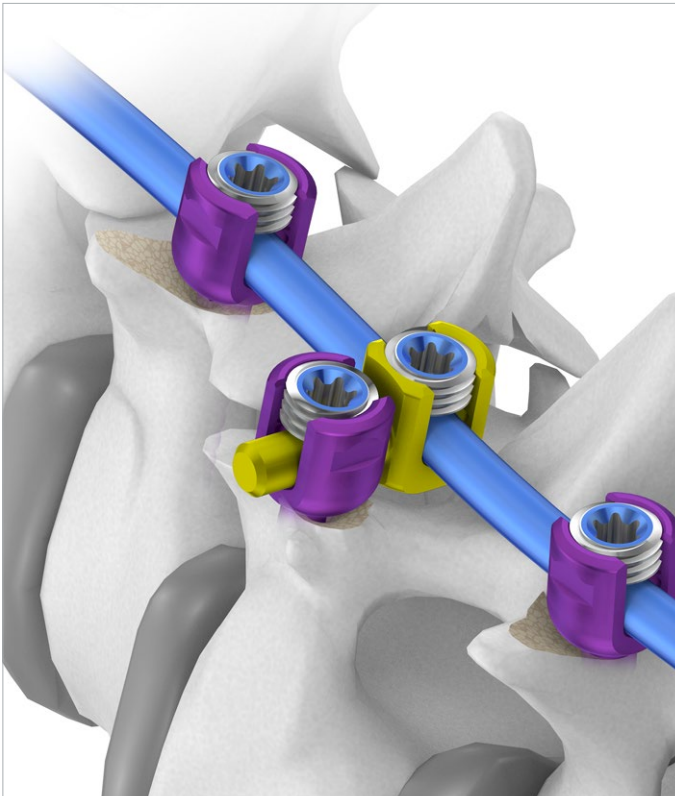

If it is needed to lengthen the fixation in lateral direction (*in relation to the main axis of stabilization*), it is possible to use a lateral connector. The connector is put on the main rod, then it is locked in a desired position (*after mounting the appropriate transpedicular screw*).

4.8. INTRODUCTION OF POLYAXIAL SCREWS INTO THE PELVIS

Polyaxial screws for pelvis extend the lumbosacral stabilization and provide the fixation in the pelvic bone. The screw offers an increased, asymmetrical range of motion in one of the planes, facilitating screw-to-rod fixation.

The screw insertion hole is prepared using a universal [40.8071.000] or straight pedicular trocar [40.8072.000].



Pedicular trocar may not provide an opening corresponding to the full length of the screw for pelvis. This should be confirmed intraoperatively by X-Ray imaging.

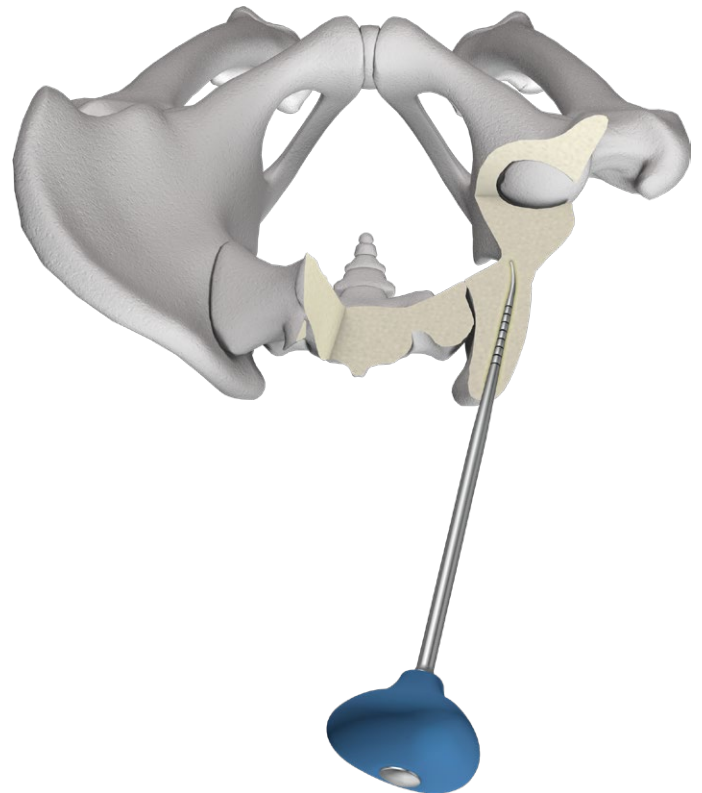
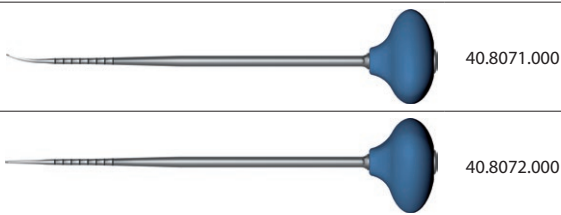

The optimum insertion trajectory of the screw for pelvis starts above the incisura ischiadica major and ends in the quadrilateral area of the pelvic bone above the linea glutea inferior. This trajectory ensures optimum fixation of the screw in the bone.

Polyaxial screw of a determined size is screwed into the prepared pelvic opening using the wrench for polyaxial screws [40.8090.100], attached to the T-handle [40.6678.120] or oval handle [40.8086].

It is recommended to use osteotome (or *rongeur*) to remove a fragment of the iliac crest around the screw head or to sink the screw head in the bone to avoid any screw prominence, especially when slim patients are concerned.

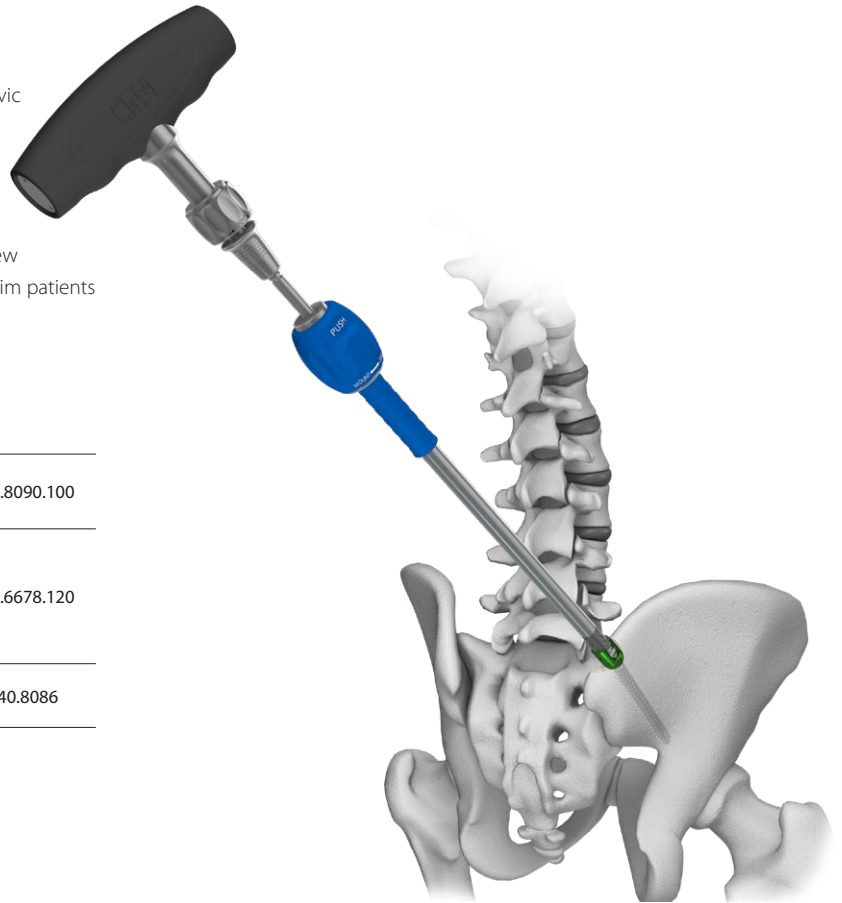
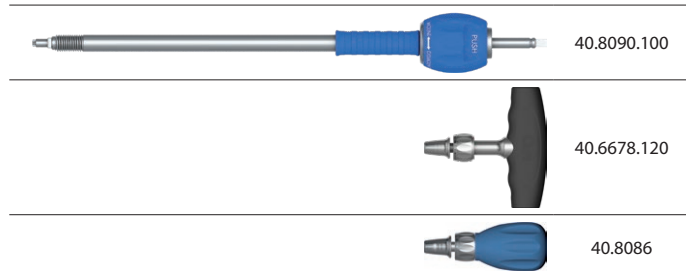

Most often the standard straight rod, e.g. [3.3246.xxx] is used for stabilization. The rod should be profiled so that the screw inserted into the S1 vertebra can be connected with the screw inserted into the pelvis.

It is also possible to use factory profiled rod, e.g. [3.3981.xxx] should any difficulties with rod shaping appear.

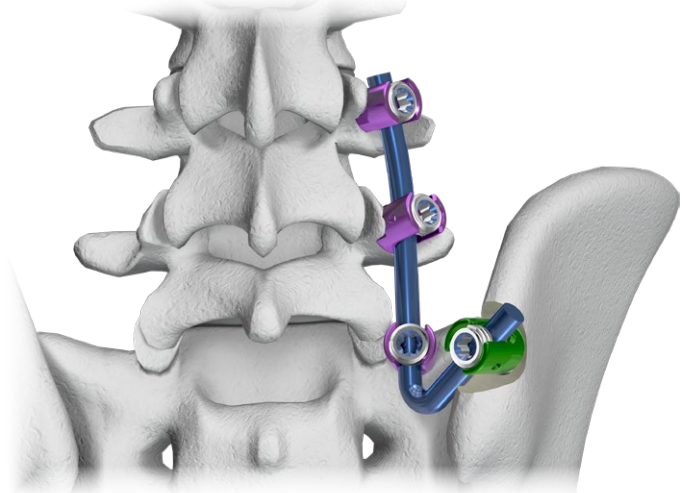

A lateral connector, e.g. [3.6283.xxx] may also be used to connect the rod with the screw inserted into the pelvis.

Locking of the polyaxial screw for pelvis is performed in the same way as for standard polyaxial screws.

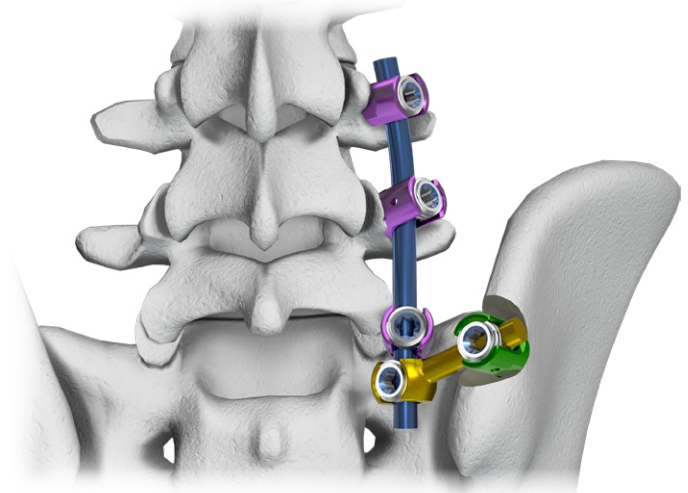

4.9. IMPLANT REMOVAL

To perform revision, the following steps should be taken (*observing the order provided*).

1. Use the screwdriver T30 [40.8111.000] to loosen and remove the locking screws.
2. Use the pliers for rod [40.8109.000] to remove the rods.
3. Remove the transpedicular screws. Depending on the implant, use either the wrench for monoaxial screws [40.8089.100] or wrench for polyaxial screws [40.8090.100].

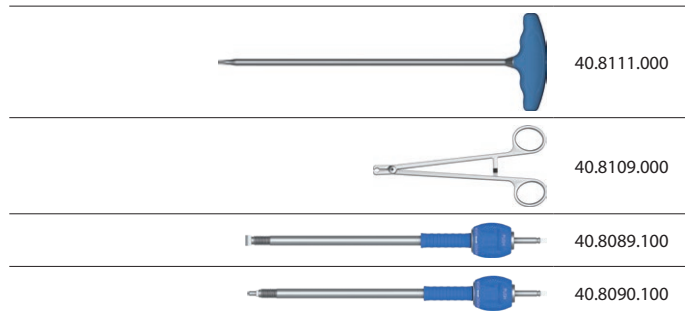

4.10. CEMENT AUGMENTATION OF SCREWS (OPTIONAL)

If bone cement is to be injected into the vertebral body, use fenestrated screws offered in a separate ChM implants system - **CHARSPINE2 MIS** (catalog pages for fenestrated screws are provided in a separate surgical technique - ST-86).



CAUTION:

Use always guide rod introduced into the pedicle to insert fenestrated screws. The implantation of the fenestrated screw without the use of the guide rod can cause the bone material to be forced into the cannula of the screw and, consequently, make cement injection hindered or impossible.



The procedure for fenestrated screws implantation described below requires the use of special, dedicated cannulated instruments, which are not a part of the basic instrument set for open stabilization [15.0907.001].

For the instruments below to be supplied, please contact your local representative or ChM Sales Department.

4.10.1. GUIDE ROD INSERTION

To insert the guide rod, use the trocar [40.8601.000]. Alternatively, a disposable trocar, size 13G can be used.

The trocar insertion point is located at the intersection of the line dividing the transverse processes in half and the line running along the lateral edge of the upper articular process.

Insert the trocar through the pedicle into the vertebral body until the desired depth is reached.



Make sure the trocar has been correctly inserted by taking lateral and A/P images.

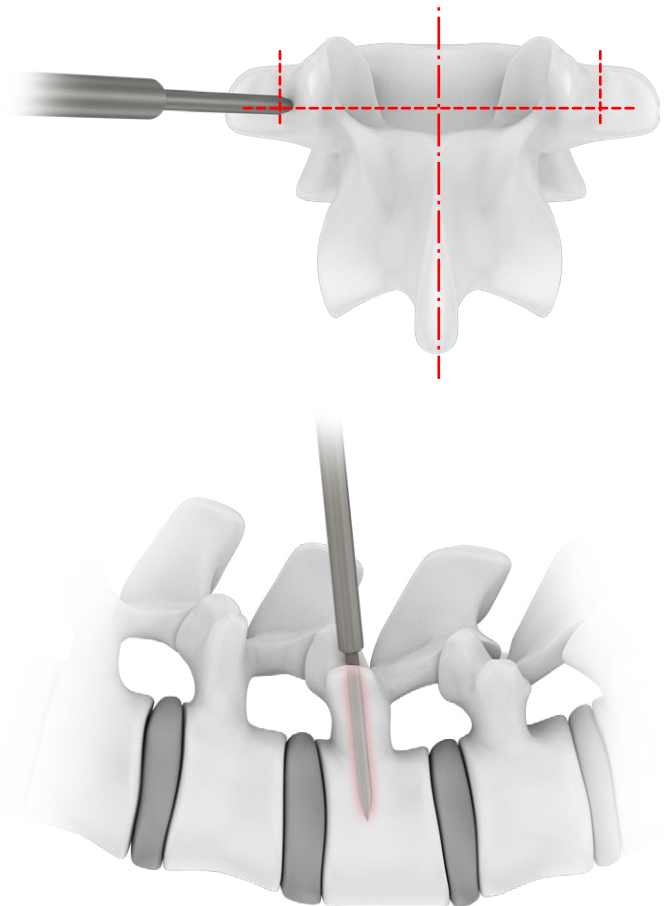



The trocar is equipped with a depth limiter that determines the depth of insertion of the trocar tip. The depth limiter may also be used to determine the length of the screw to be used.

Depth of insertion

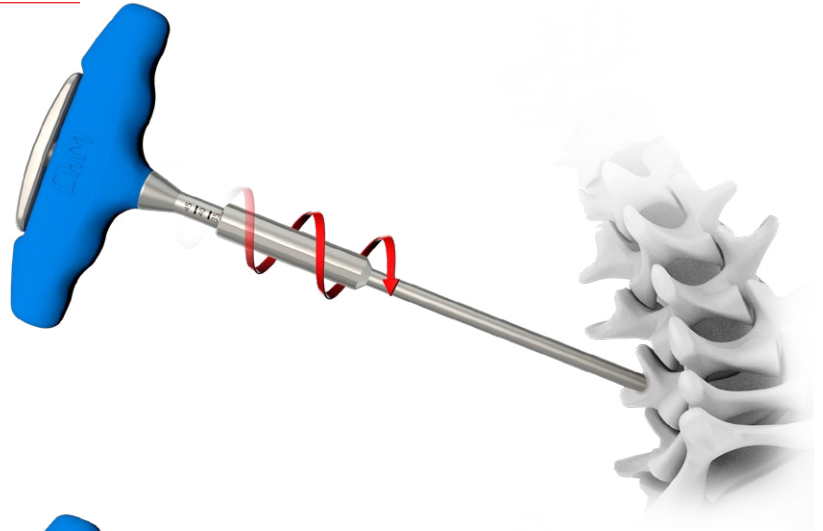

After trocar insertion, remove the pin.

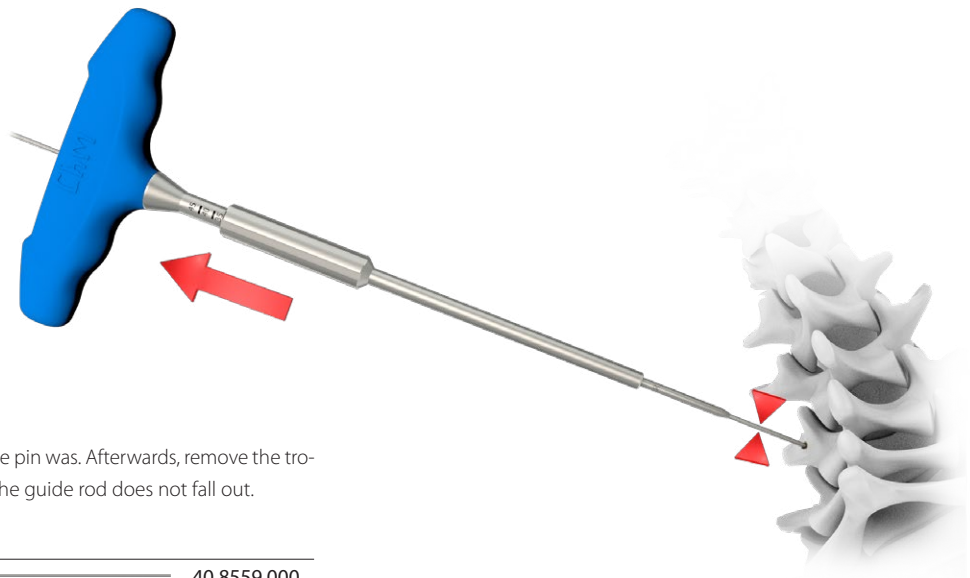
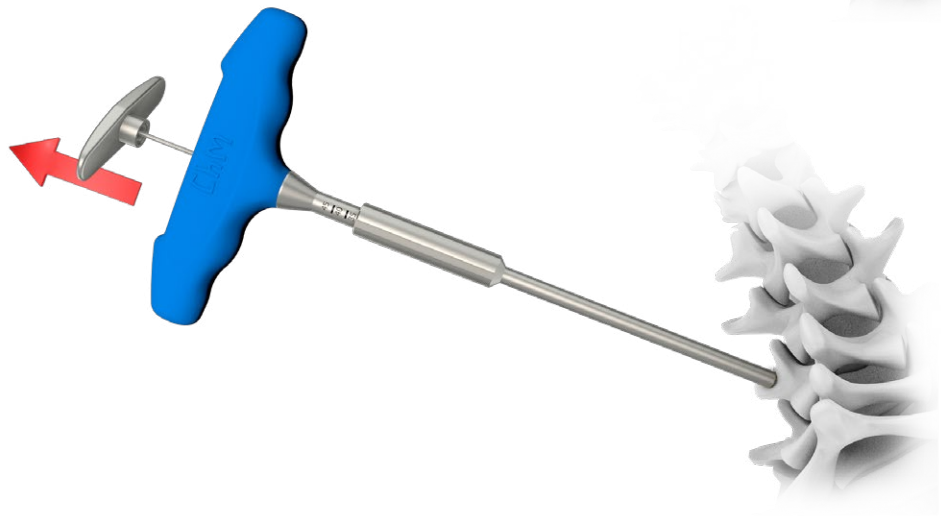

Insert the guide rod [40.8559.000] where the pin was. Afterwards, remove the trocar. When removing the trocar, make sure the guide rod does not fall out.

40.8559.000

4.10.2. HOLES THREADING (OPTIONAL)

CHARSPINE2 MIS fenestrated screws are self-tapping, therefore, in most cases, there is no need to thread the pedicles of vertebral arches. However, for clinical cases requiring threading, cortical taps [40.8567.045-40.8567.105] mounted in the oval head ratchet handle [40.8086.000] can be used.

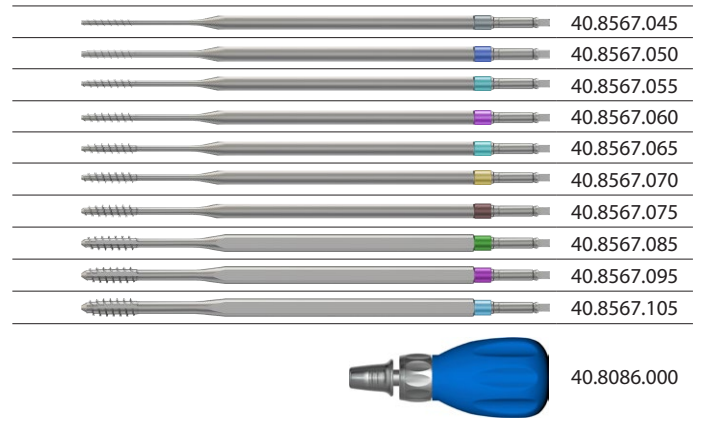

4.10.3. SCREWS INSERTION

For fenestrated screws insertion, use cannulated wrench for polyaxial screws [40.6735.100] and oval head ratchet handle [40.8086.000].

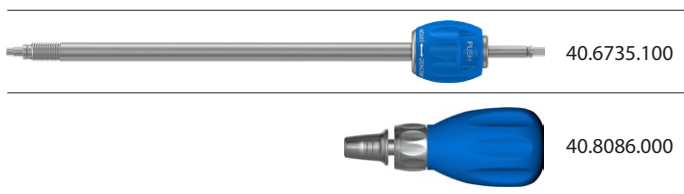

Choose the pedicle screw of correct length and diameter and install in the wrench.

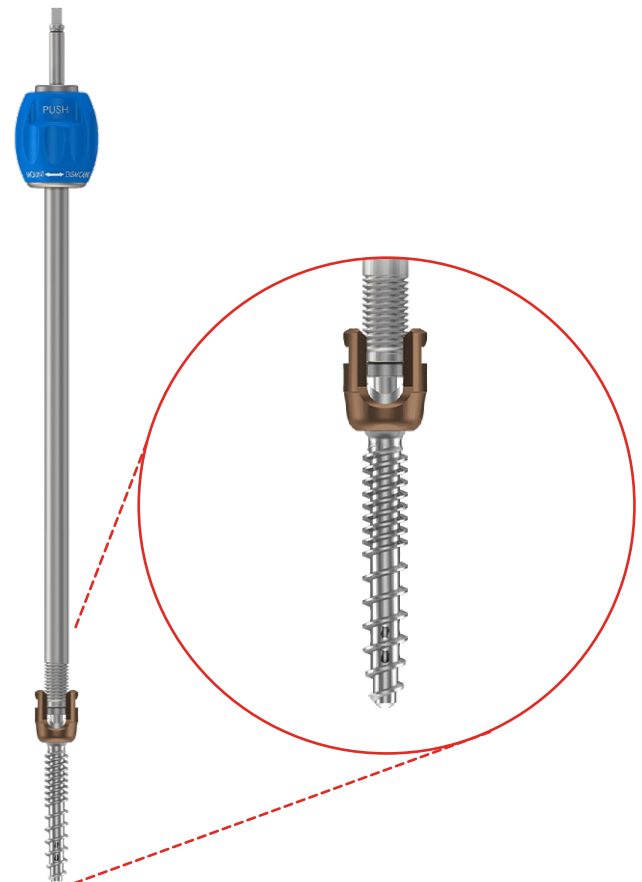

Turn the wrench knob clockwise to tighten the threaded outer sleeve of the wrench [40.6735.100] until the tip is fully seated in the bottom of the screw socket. The tightening direction is marked with an arrow and the word MOUNT. When tightening, with increasing resistance, the wrench knob will automatically move to the position that activates the mechanism preventing the screw from loosening.

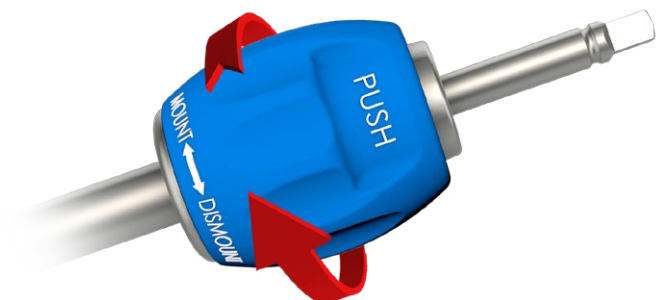

Use the guide rod to insert the screw into the hole in the pedicle.



The screws insertion should be controlled in two planes using a fluoroscope.



It should be remembered that the correct screws positioning is achieved by screwing in the screws and not by screwing them out.

Backing the screw out may result in the loss of a stable anchoring and the need for use of a larger diameter screw.



When implanting the screw, do not hold the oval knob of the wrench, as this will disengage the safety mechanism.



If there is a need to use the other hand to hold the wrench, hold the part of the sleeve below the oval knob.

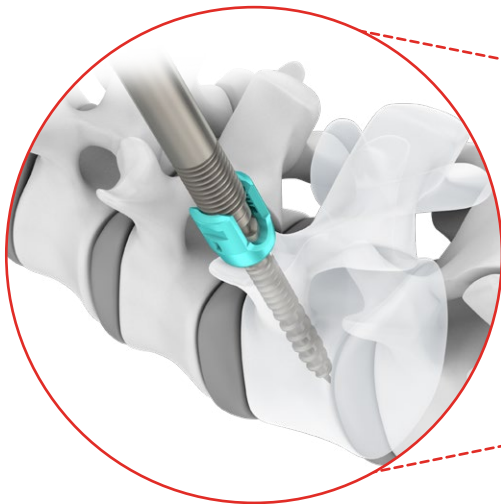
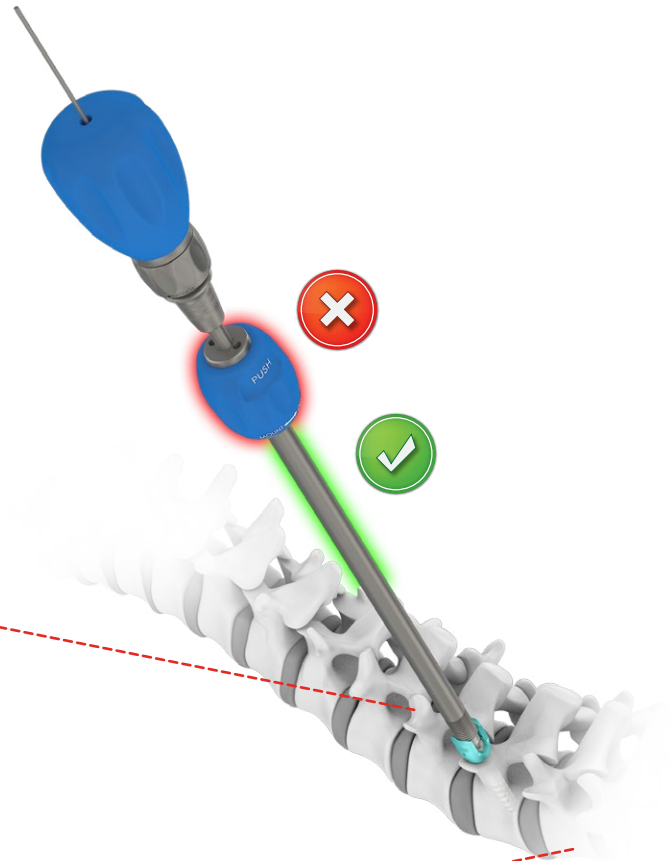

To remove the wrench [40.6735.100] from the screw, loosen the threaded sleeve of the wrench by turning the oval knob counterclockwise (*the direction is marked with an arrow and the word DISMOUNT*). When loosening, the wrench locking mechanism disengages automatically.



CAUTION:
Do not remove the guide rod!



Repeat the steps described in chapter IV.12.3, and introduce the required number of screws.

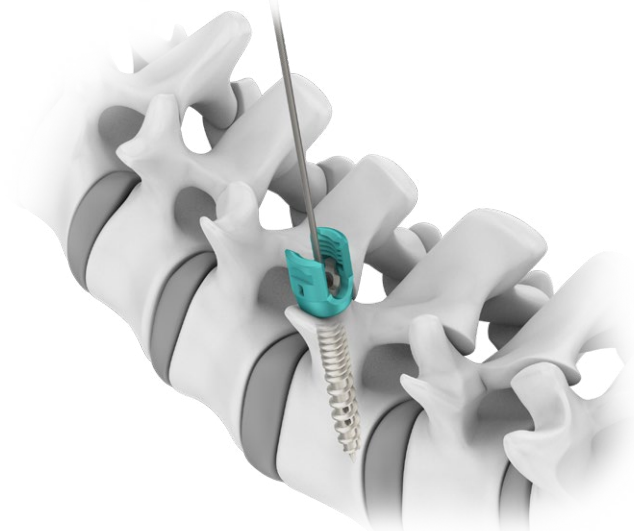
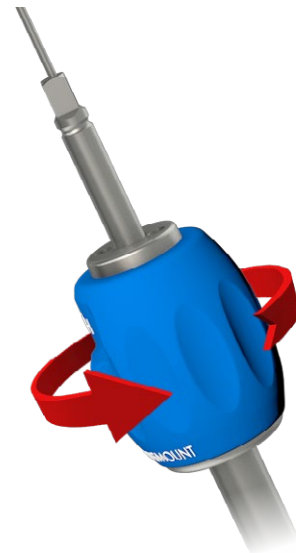

4.10.4. USE OF CANNULA FOR BONE CEMENT

For a bone cement to be injected into the vertebral body, install the cannula for bone cement [40.8591.000] to the implanted screw (before removing the guide rod). To do this, hold the flattened tip of the cannula and insert the other end, through the guide rod, into the screw head and then tightened it up (clockwise rotation).

While installing the cannula, use the counter wrench [40.6749.000] to immobilize the screw head.

Afterwards, the guide rod can be removed.

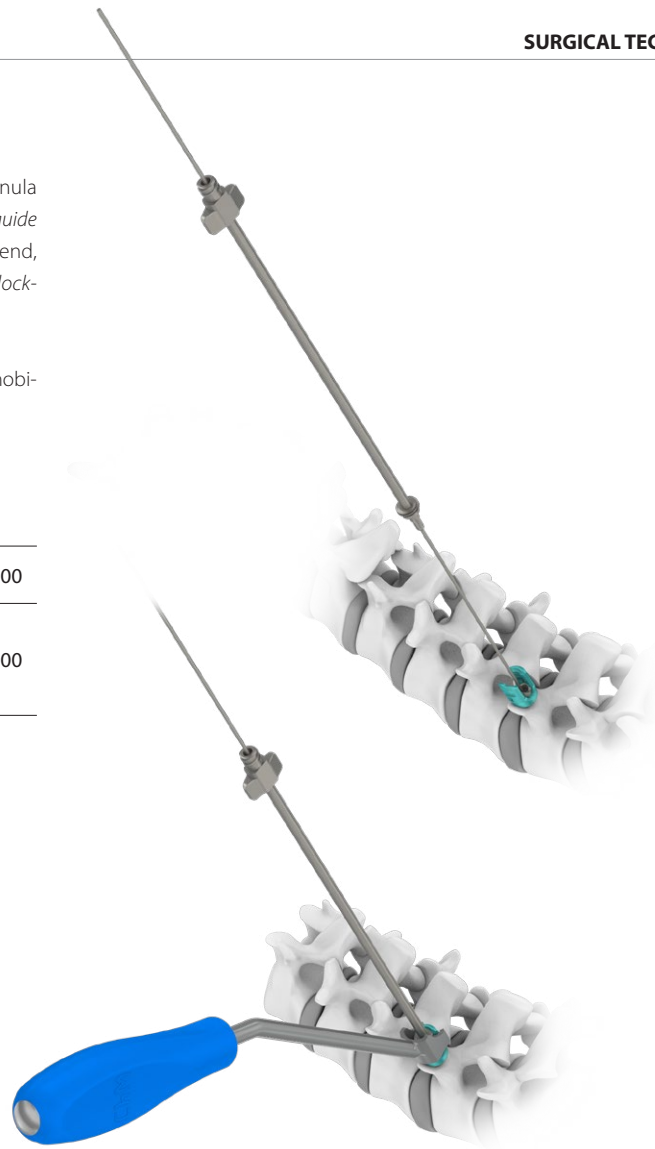
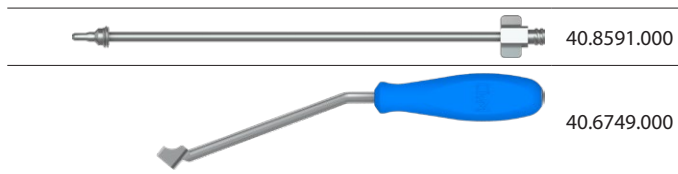

To confirm the coaxiality of the holes in the cannula and the screw, use the alignment trial for cannula [40.8592.000] (not included in the standard instrument set). The trial should be inserted into the cannula until stop.

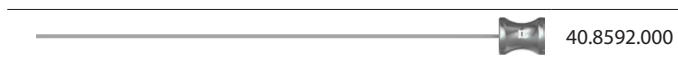

If the alignment trial cannot be fully inserted, the cannula for bone cement has not been properly connected to the screw. In such situation, loosen slightly the cannula in the screw (counterclockwise rotation), reposition the screw head and then push the trial to the end and tighten fully the cannula.

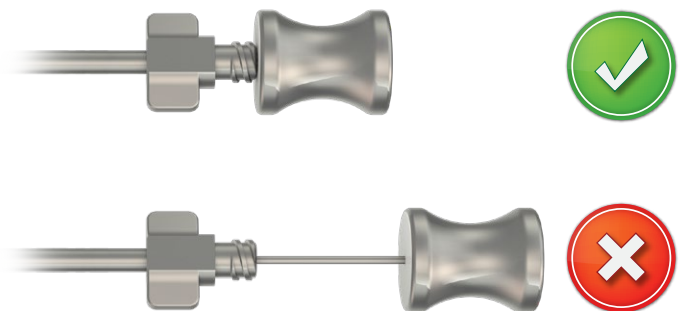

Should the screw been inserted so deep that the screw head was immobilized by the neighbouring bone, it may be necessary to slightly back out the screw to allow the head to move and the cannula to be properly inserted.



Incorrect connection of the cannula with the screw can cause cement leakage at the connection point. Only use ChM cannula for bone cement supply.

Before cement injection, all cannulas for bone cement should be attached to the screws.

4.10.5. CEMENT PREPARATION AND INJECTION

For cement preparation, refer to the Instructions for Use for bone cement and cement mixing/delivery device system. The cannula for bone cement is equipped with a standardized Luer Lock thread, enabling a tight connection with the cement mixing/delivery device.



The volume of cement in the cannula [40.8594.000] is 1.2 ml.

Mix the cement as instructed and suck it into the cement mixing/delivery device. Before injecting, wait until the cement reaches the right viscosity.



Fluoroscopy should be used throughout the cement injection procedure to control the cement flow.

When using cement to augment multiple screws and levels, attention must be paid not to exceed the working time of the cement prior to completion of cement delivery through the screws. When the cement working time is close to complete, a new cement package should be used.



The cannula for bone cement as well as the mixing/delivery device are designed for use with one package of bone cement only. If a second package of cement is needed, use a new cannula and mixing/delivery device.

Do not attempt to force the injection of cement if excessive resistance is felt. Always determine the cause of the resistance and take appropriate action. If the cement is seen outside of the vertebral body or in the circulatory system during the procedure, immediately stop injecting the cement.

Use pusher [40.8596.000] to remove the residual cement from the cannula (1.2 ml). Insert the pusher down the cannula. The pusher handle needs to rest against the cannula.



CAUTION:
Wipe clean the pusher after each use, thoroughly.

 40.8596.000



4.10.6. REMOVAL OF THE CANNULA FOR BONE CEMENT

After cementing, unscrew the cannula from the screw. Hold the counter wrench [40.6749.000] with the other hand to counteract the removal process. Use wrench [40.8580.000] to facilitate unscrewing, if required.

Back out the cement feeder slightly to ensure that after cementing and before removing the cannula from the screw, the cement flow has been stopped.



It is critical that no torsion movement should be applied to the screw after injecting the cement in order to avoid breaking the cement bridges between the screw and bone.

The cannula for bone cement and cement mixing/delivery device are disposable equipment and must be discarded after cementing.



40.6749.000



40.8580.000

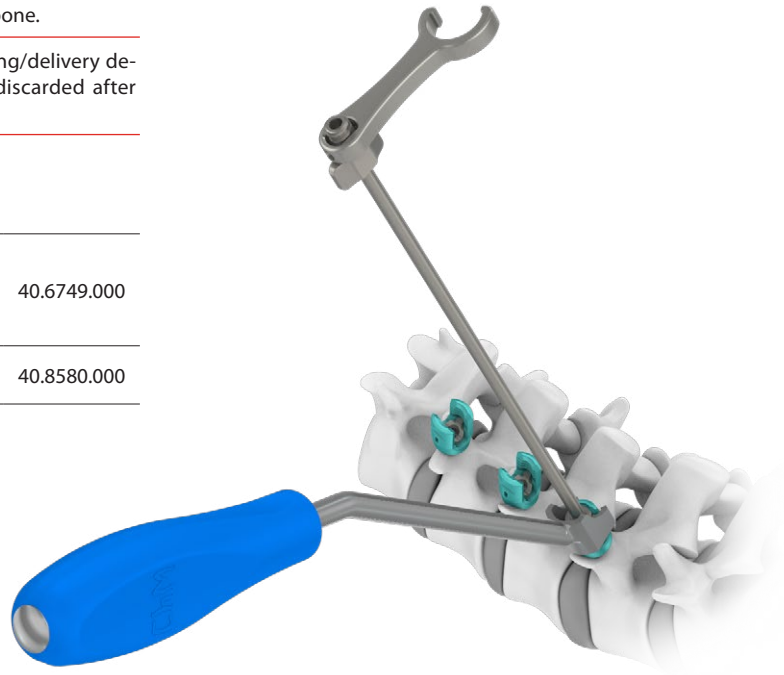

ChM sp. z o.o.

Lewickie 3b
16-061 Juchnowiec Kościelny
Poland

tel. +48 85 86 86 100

fax +48 85 86 86 101

chm@chm.eu

www.chm.eu



CE 0197